

PLAN VIEW

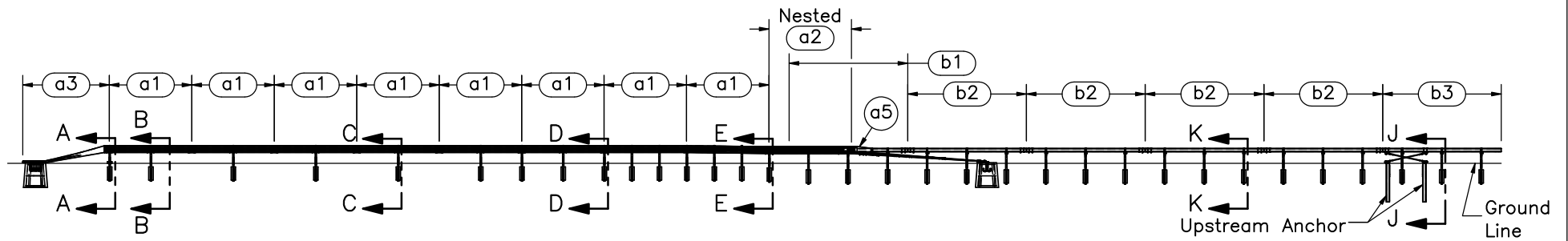

ELEVATION VIEW

- Notes: (1) Test shall be performed according to test designation no. 3-21 using MASH 2016 criteria.
 (2) The impact location is 8' [2,438] upstream from the leading edge of the transition cover piece (part a5).
 (3) Critical region is located between post nos. 10 and 27.
 (4) Upstream anchor posts are placed in $\phi 3'$ [914] holes, then backfilled and tamped with soil.



Midwest Roadside Safety Facility

NY Box Beam to Weak Post
 W-Beam Transition
 Test No. NYBWT-2

System Layout

DWG. NAME:
 NYBWT-2_R2

SCALE: 1:280
 UNITS: in.[mm]

SHEET:
 1 of 34
 DATE:
 10/27/2023
 DRAWN BY:
 JEK/JRD/JJ
 O
 REV. BY:
 KAL

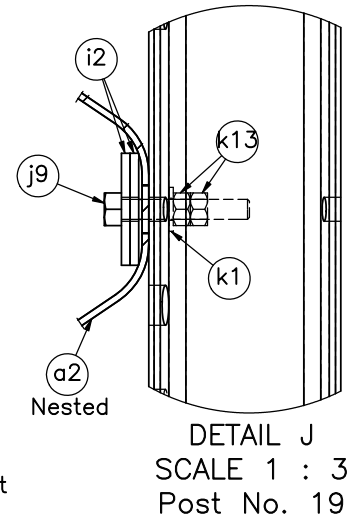
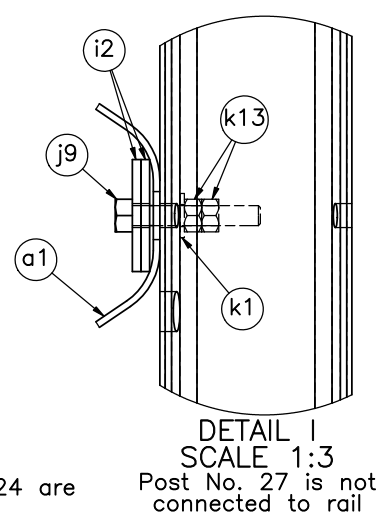
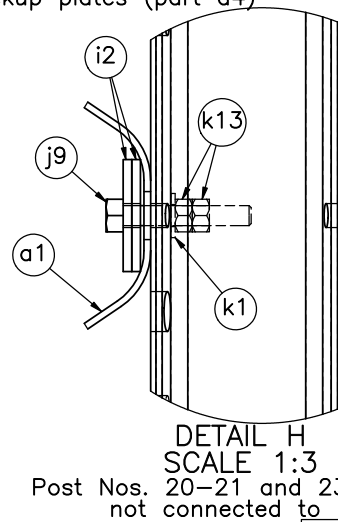
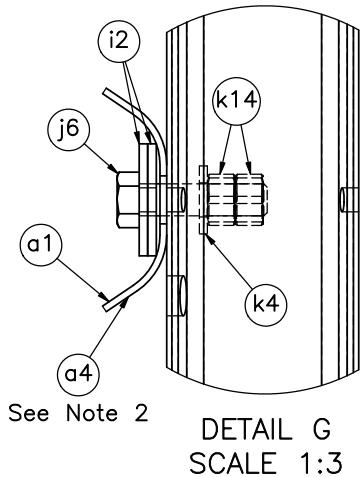
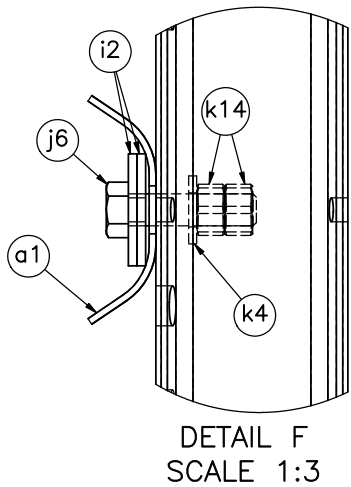
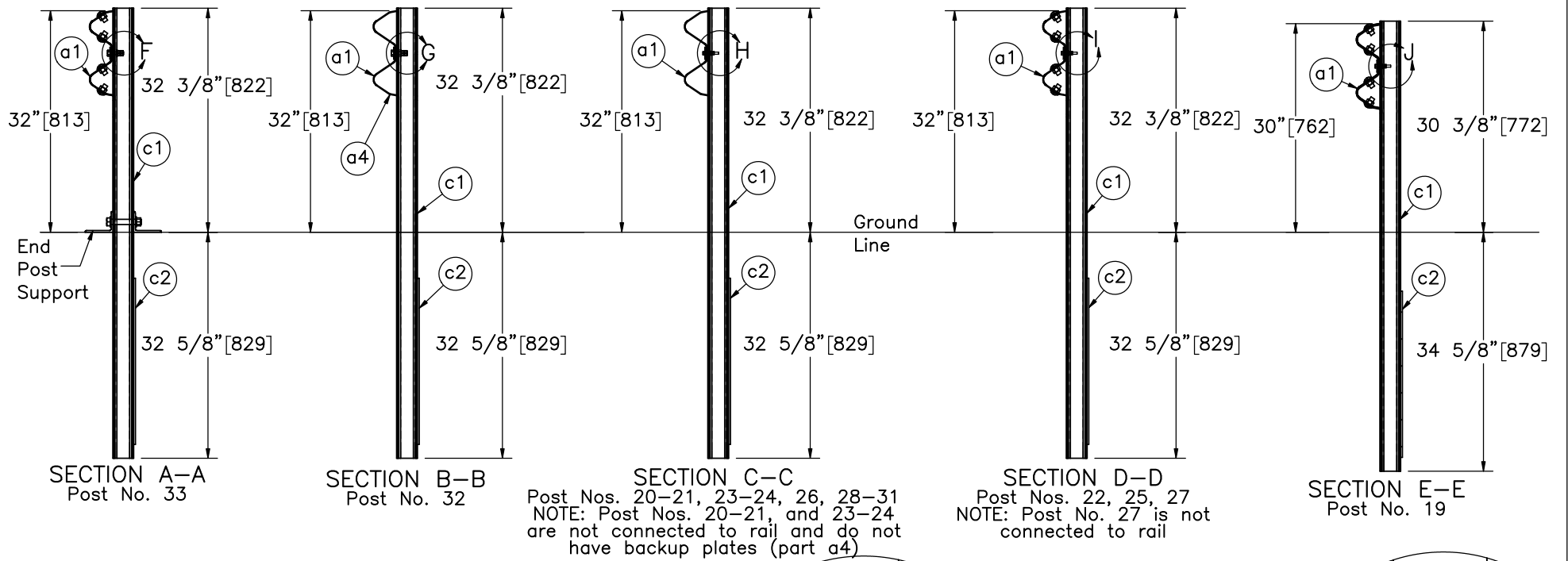

Note: (1) Guardrail bolts (parts j6 and j9) on the downstream side of the web.
(2) W-Beam back up plate (part no. a4) used on Posts 26, 28-32.



Midwest Roadside Safety Facility

NY Box Beam to Weak Post

W-Beam Transition

Test No. NYBWT-2

W-Beam Post Sections

DWG. NAME:
NYBWT-2_R2

SCALE: 1:22
UNITS: in.[mm]

SHEET:
2 of 34

DATE:
10/27/2023

DRAWN BY:
JEK/JRD/JJ
O

REV. BY:
KAL

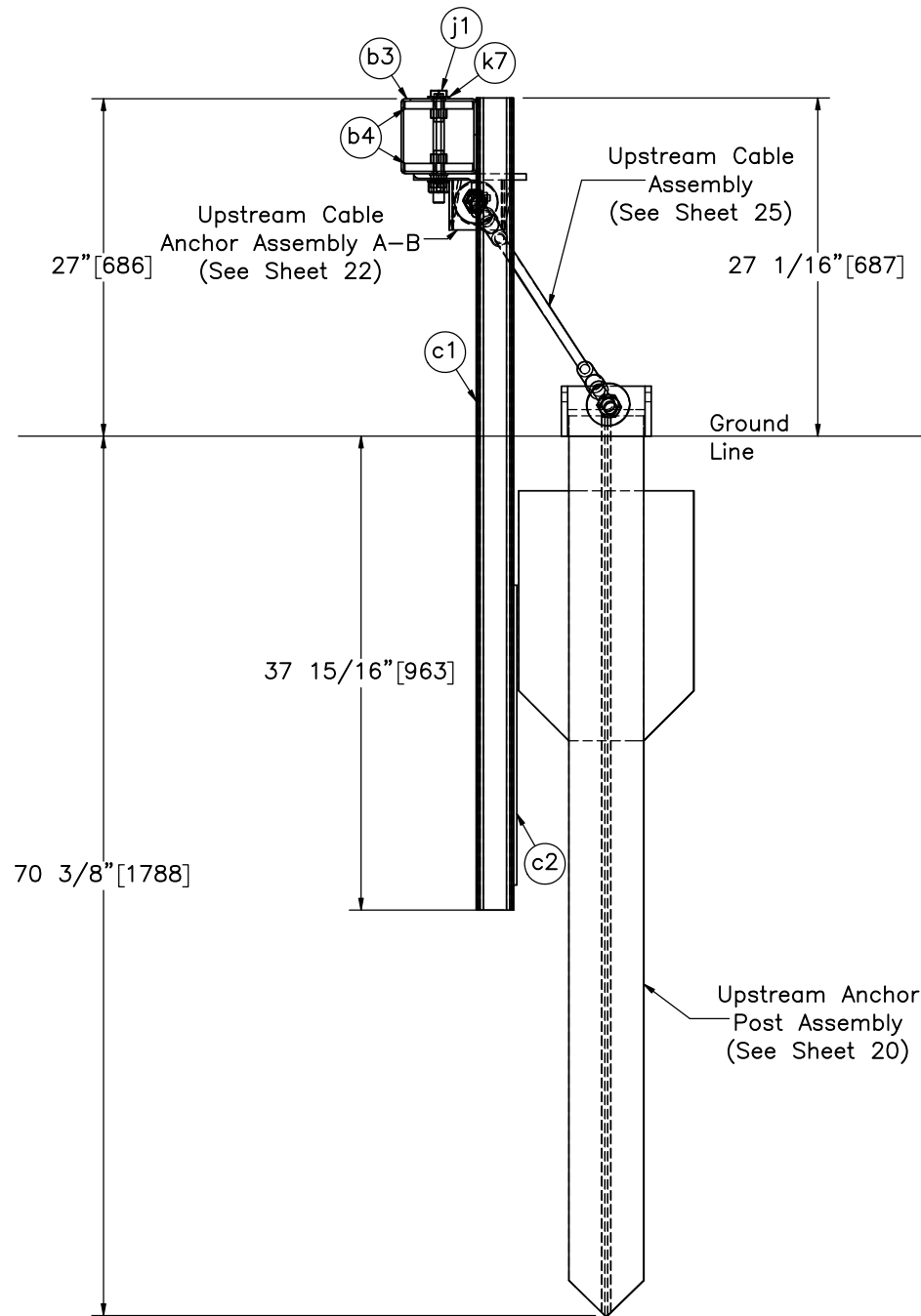

SECTION J-J

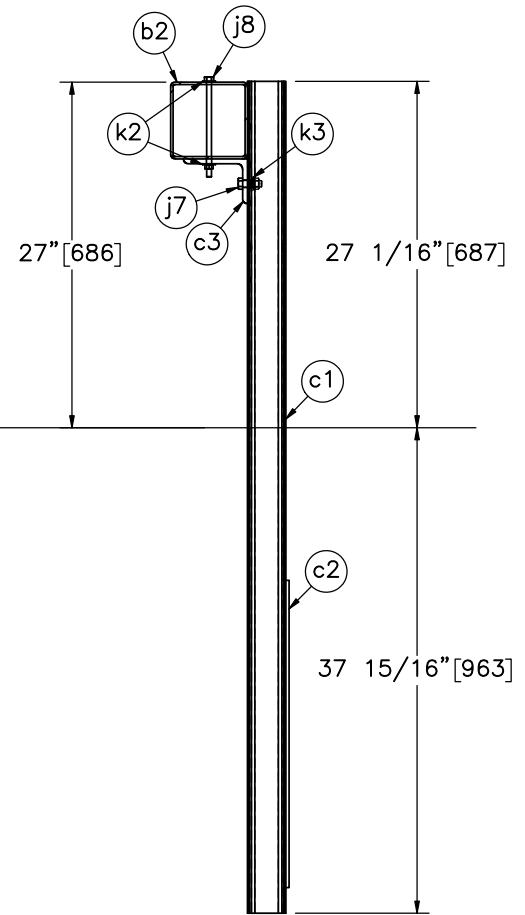

SECTION K-K

Note: (1) Box beam post bolts (part j7) on the downstream side of the web.



Midwest Roadside
Safety Facility

NY Box Beam to Weak Post
W-Beam Transition
Test No. NYBWT-2

Box Beam Post Sections

DWG. NAME:
NYBWT-2_R2

SCALE: 1:15
UNITS: in.[mm]

SHEET:
3 of 34

DATE:
10/27/2023

DRAWN BY:
JEK/JRD/JJ
O

REV. BY:
KAL

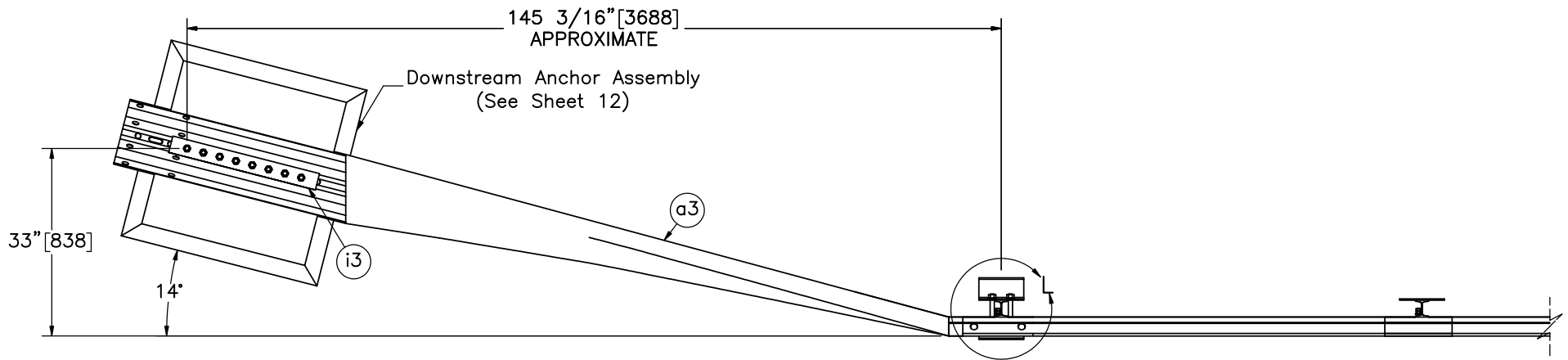

PLAN VIEW

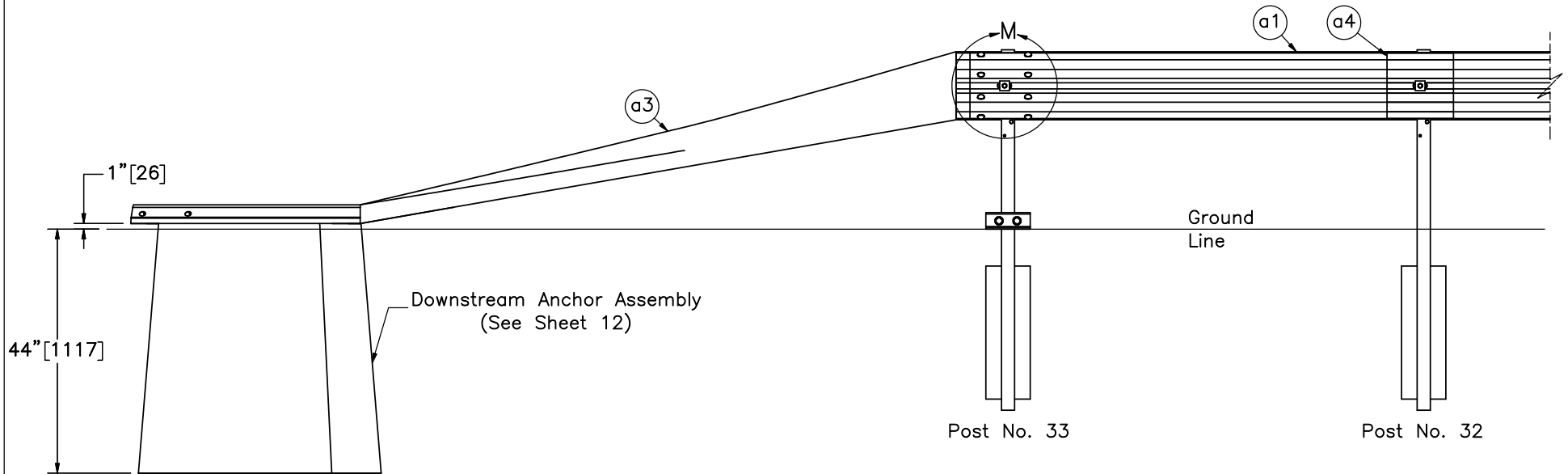

ELEVATION VIEW



Midwest Roadside
Safety Facility

NY Box Beam to Weak Post
W-Beam Transition
Test No. NYBWT-2

Downstream Anchorage Details

DWG. NAME:
NYBWT-2_R2

SCALE: 1:28
UNITS: in.[mm]

SHEET:
4 of 34

DATE:
10/27/2023

DRAWN BY:
JEK/JRD/JJ
O

REV. BY:
KAL

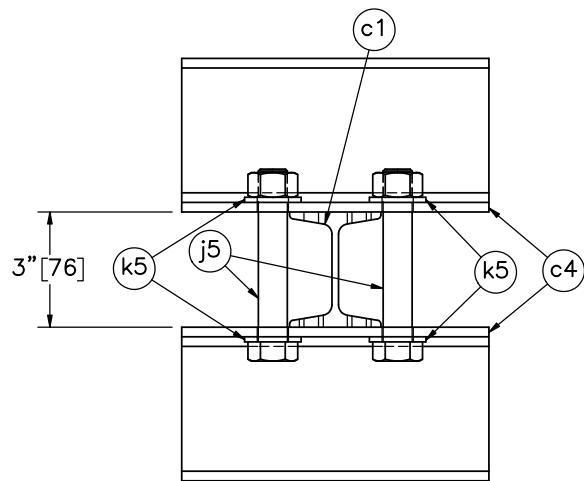

DETAIL L
END POST SUPPORT
Post No. 33

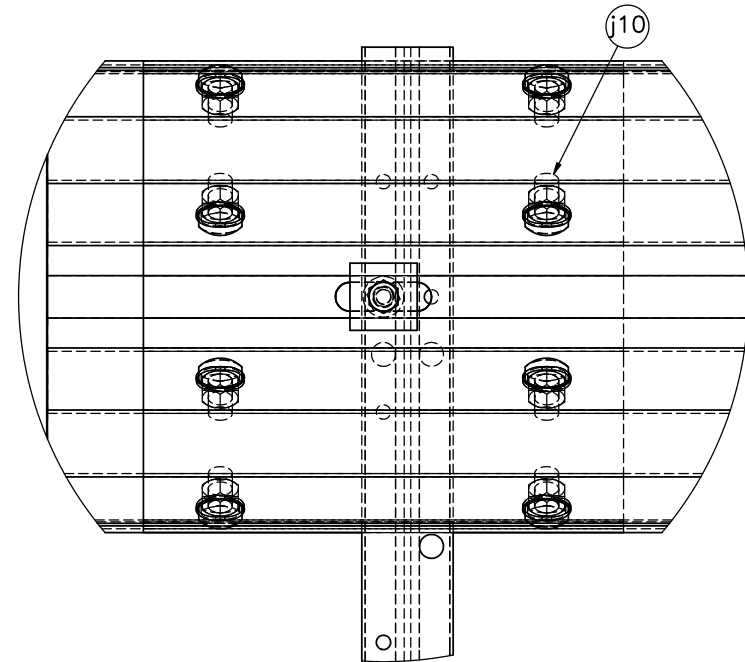

DETAIL M

- Notes: (1) Rail and attachment hardware hidden in Detail L for clarity.
 (2) Bolts on the end post support should be torqued to 100 ft-lb (+20, -0) [135.6 Nm (+27.1, -0)] after post is driven.



Midwest Roadside
Safety Facility

NY Box Beam to Weak Post
W-Beam Transition
Test No. NYBWT-2

End Post Support and W-Beam
Splice Detail

DWG. NAME:
NYBWT-2_R2

SCALE: 1:5
UNITS: in.[mm]

SHEET:
5 of 34

DATE:
10/27/2023

DRAWN BY:
JEK/JRD/JJ
O

REV. BY:
KAL

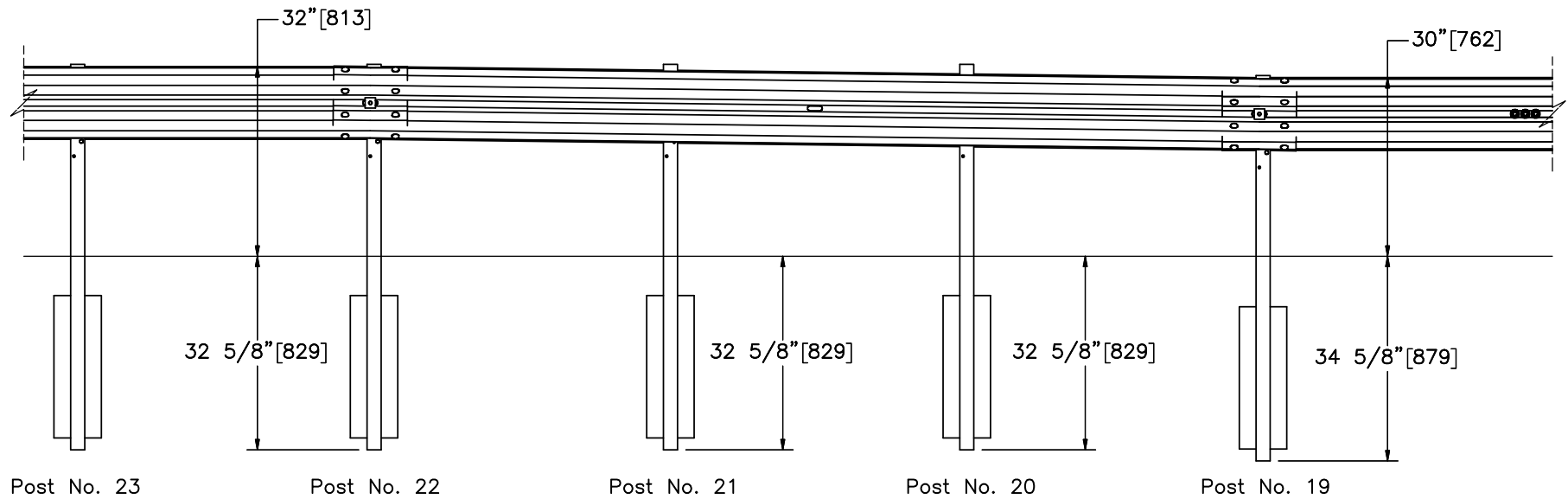

ELEVATION VIEW

	NY Box Beam to Weak Post W-Beam Transition Test No. NYBWT-2		SHEET: 6 of 34
	Rail Elevation Transition Details		DATE: 10/27/2023
Midwest Roadside Safety Facility	DWG. NAME: NYBWT-2_R2	SCALE: 1:28 UNITS: in.[mm]	DRAWN BY: JEK/JRD/JJ O
			REV. BY: KAL

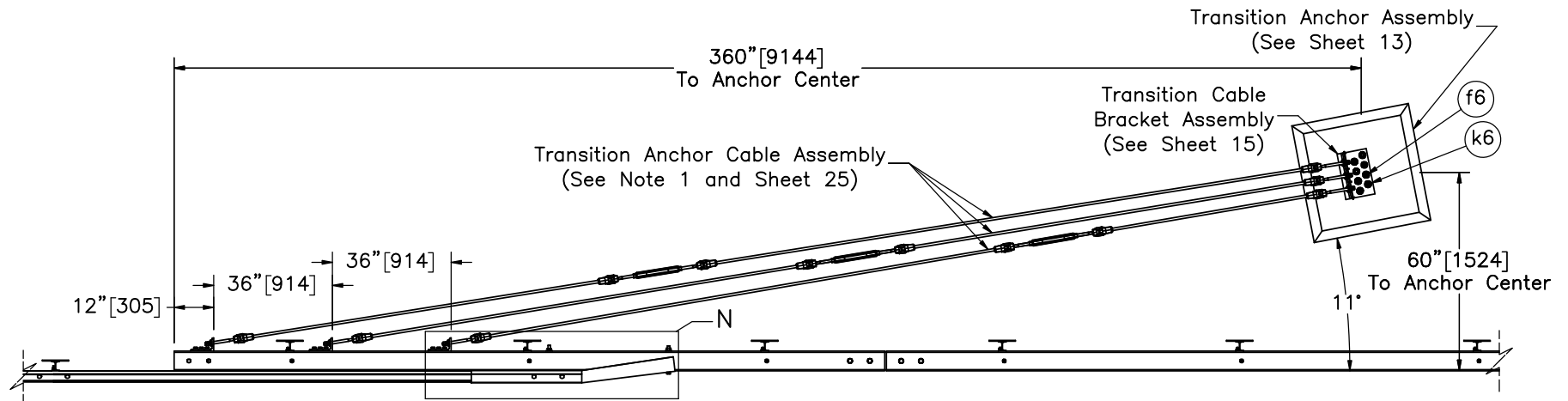

PLAN VIEW

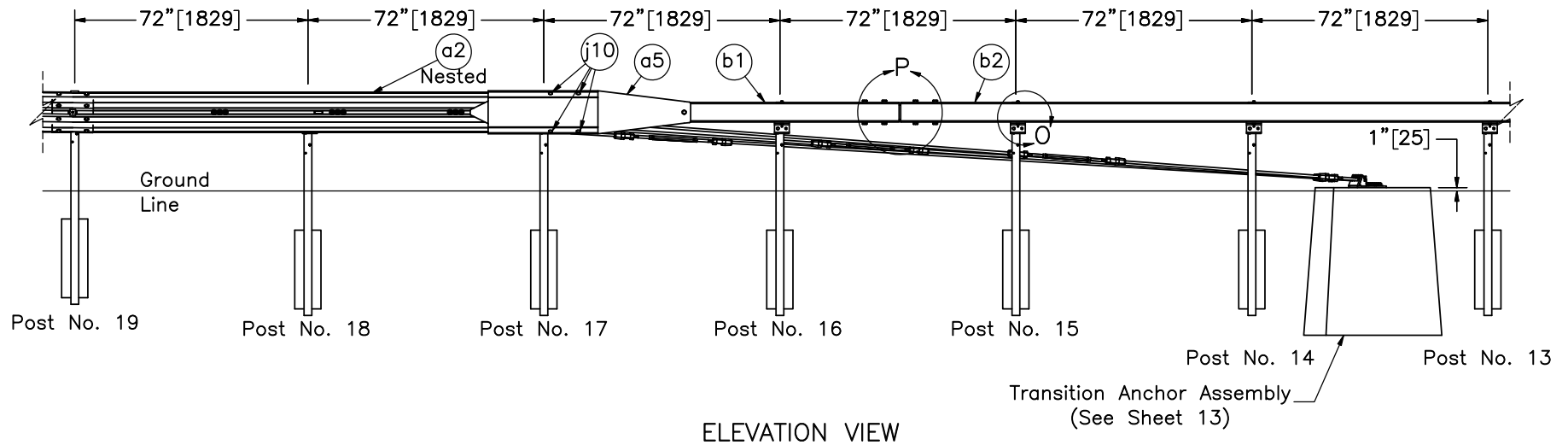

ELEVATION VIEW

Note: (1) The turnbuckles in the transition anchor cable assemblies should be approximately 5' [1.5m], 10' [3.0m], and 15' [4.6m] from the transition cable bracket assembly, with the 5' [1.5m] spacing on the cable nearest the travelway.



Midwest Roadside Safety Facility

NY Box Beam to Weak Post
W-Beam Transition
Test No. NYBWT-2

Transition Layout

DWG. NAME:
NYBWT-2_R2

SCALE: 1:50
UNITS: in.[mm]

SHEET:
7 of 34

DATE:
10/27/2023

DRAWN BY:
JEK/JRD/JJ
O

REV. BY:
KAL

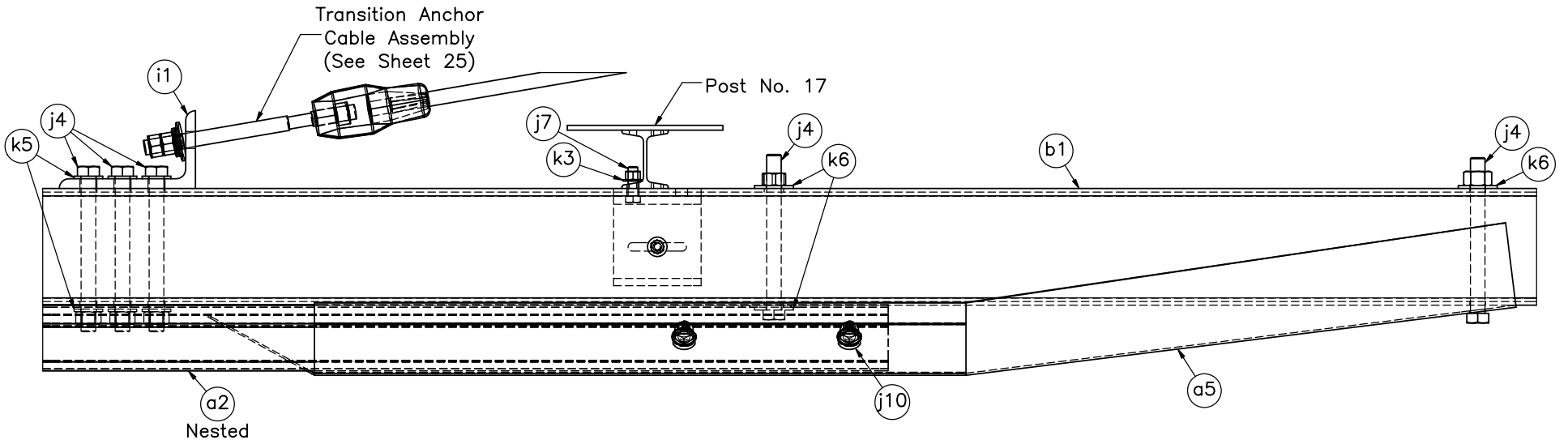

DETAIL N

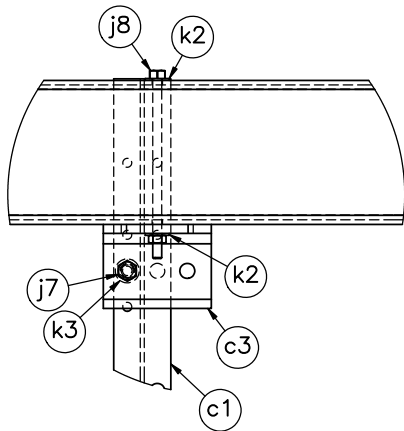

DETAIL O

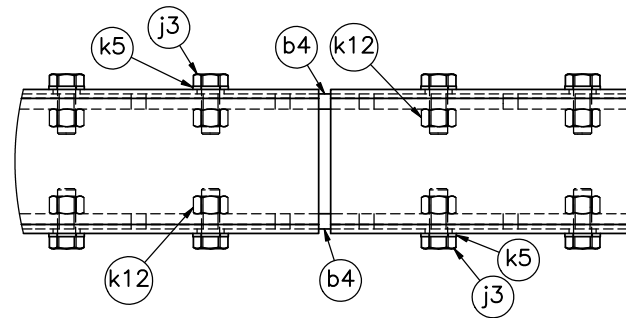

DETAIL P

Note: (1) Splice plate with tack welded nuts used for testing purposes. A splice plate with tapped holes may be used instead as noted on sheet 30.



Midwest Roadside Safety Facility

NY Box Beam to Weak Post
W-Beam Transition
Test No. NYBWT-2

Transition, Post Attachment,
and Box Splice Details

DWG. NAME:
NYBWT-2_R2

SCALE: 1:8
UNITS: in.[mm]

SHEET:
8 of 34

DATE:
10/27/2023

DRAWN BY:
JEK/JRD/JJ
O

REV. BY:
KAL

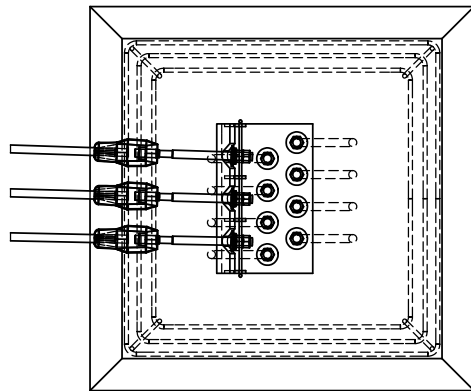

PLAN VIEW

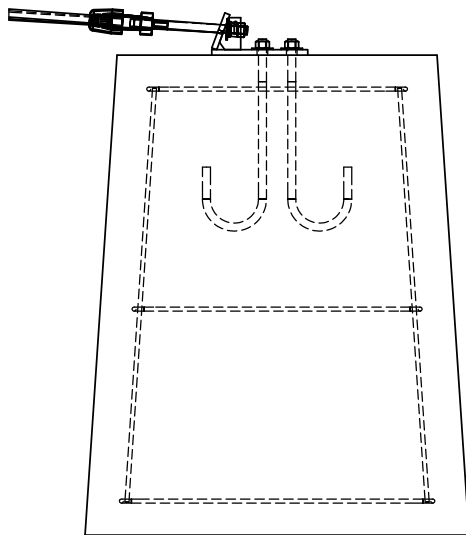

ELEVATION VIEW

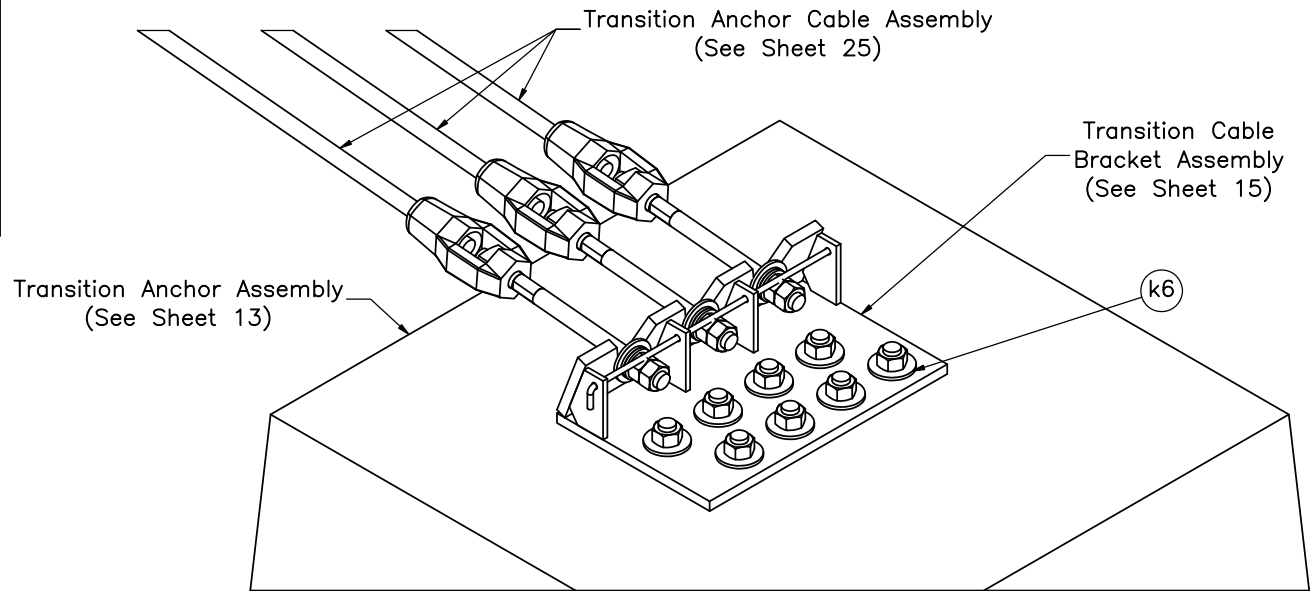

ISOMETRIC CROP VIEW
SCALE 1:8

Note: (1) When constructed, the threaded rods on the Transition Anchor Cable Assembly should have a nearly perpendicular bearing on the Transition Cable Bracket Assembly.



Midwest Roadside
Safety Facility

NY Box Beam to Weak Post
W-Beam Transition
Test No. NYBWT-2

Cable Bracket Connection
Details

DWG. NAME:
NYBWT-2_R2

SCALE: 1:18
UNITS: in.[mm]

SHEET:
9 of 34

DATE:
10/27/2023

DRAWN BY:
JEK/JRD/JJ
O

REV. BY:
KAL

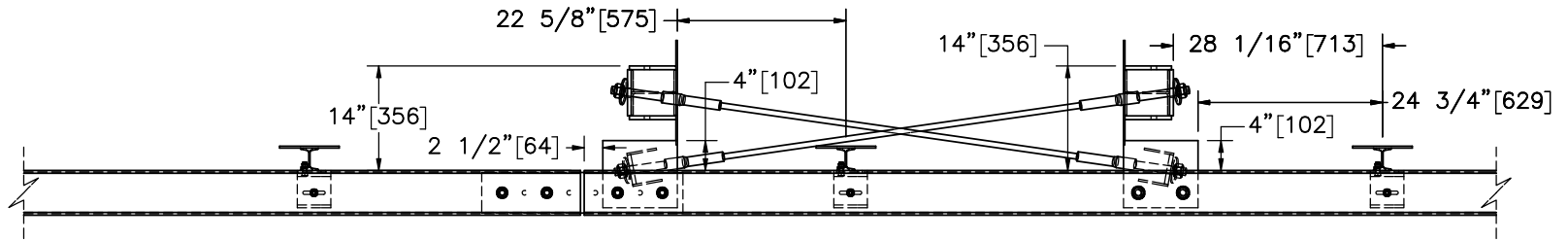

PLAN VIEW

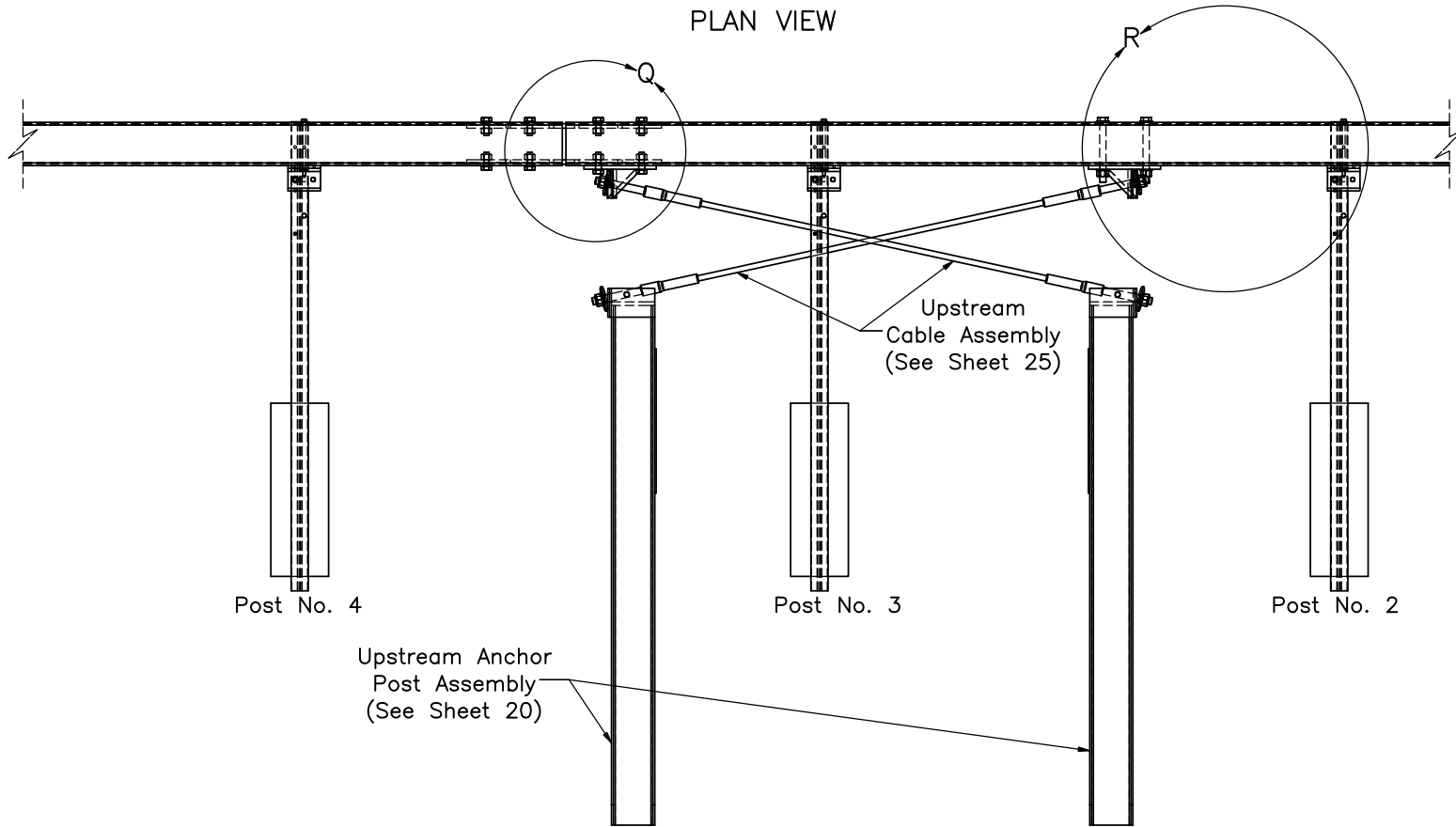

ELEVATION VIEW



Midwest Roadside Safety Facility

NY Box Beam to Weak Post
W-Beam Transition
Test No. NYBWT-2

Upstream Anchorage Details

DWG. NAME:
NYBWT-2_R2

SCALE: 1:25
UNITS: in.[mm]

SHEET:
10 of 34

DATE:
10/27/2023

DRAWN BY:
JEK/JRD/JJ
O

REV. BY:
KAL

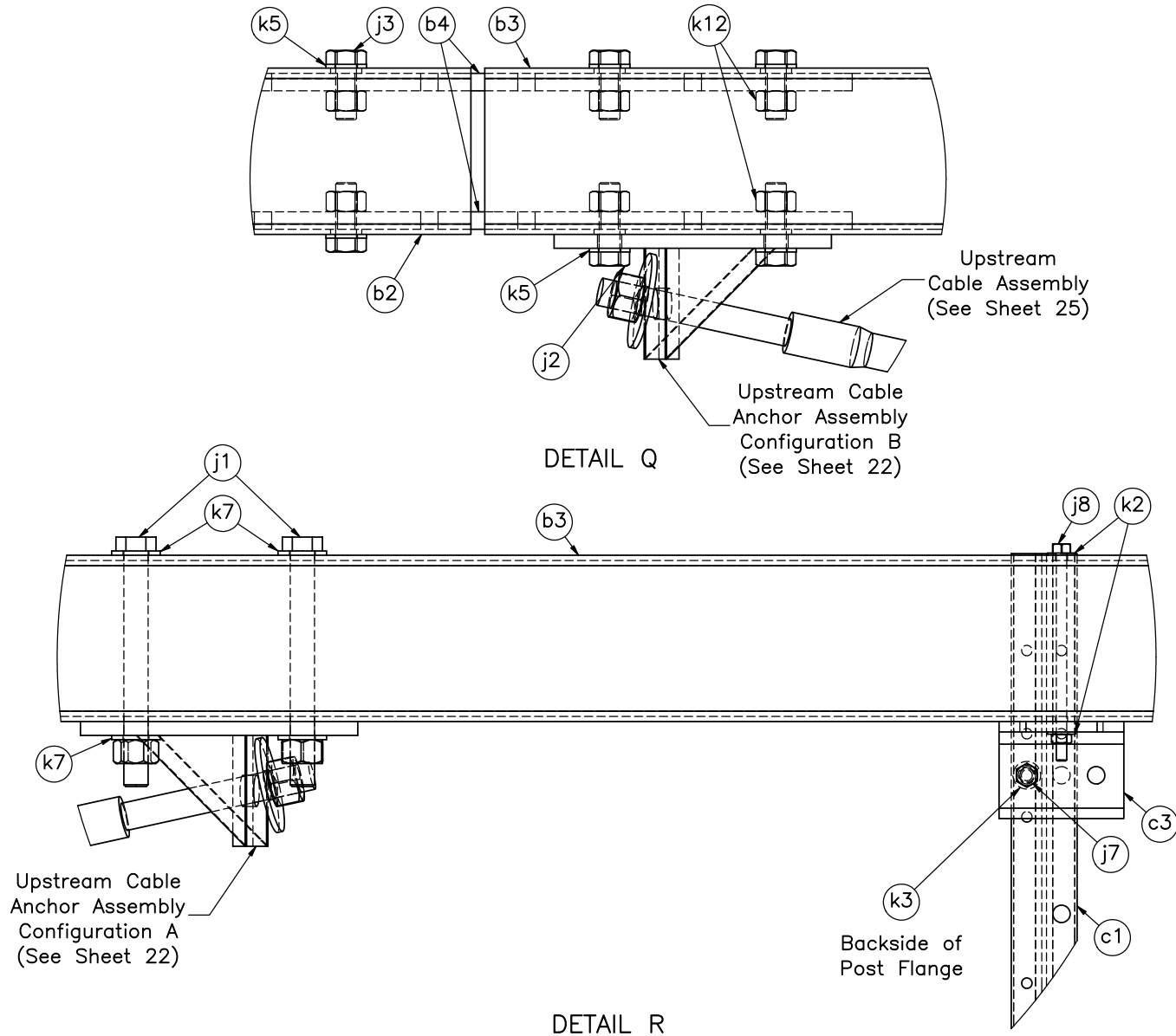

DETAIL Q

DETAIL R



Midwest Roadside
Safety Facility

NY Box Beam to Weak Post
W-Beam Transition
Test No. NYBWT-2

Upstream Anchor Mounting
Details

DWG. NAME:
NYBWT-2_R2

SCALE: 1:6
UNITS: in.[mm]

SHEET:
11 of 34

DATE:
10/27/2023

DRAWN BY:
JEK/JRD/JJ
O

REV. BY:
KAL

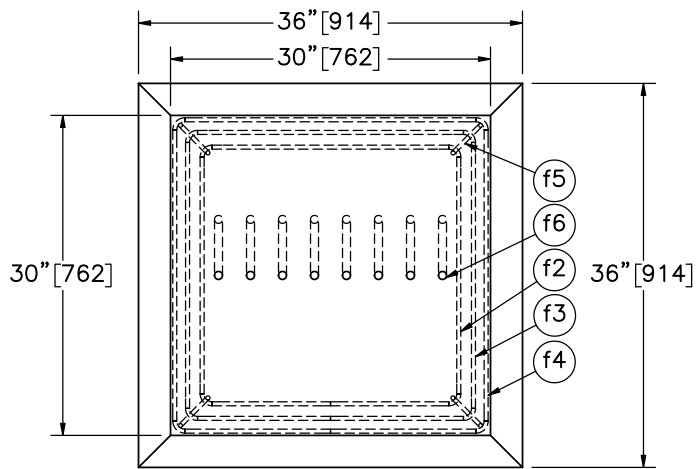

PLAN VIEW

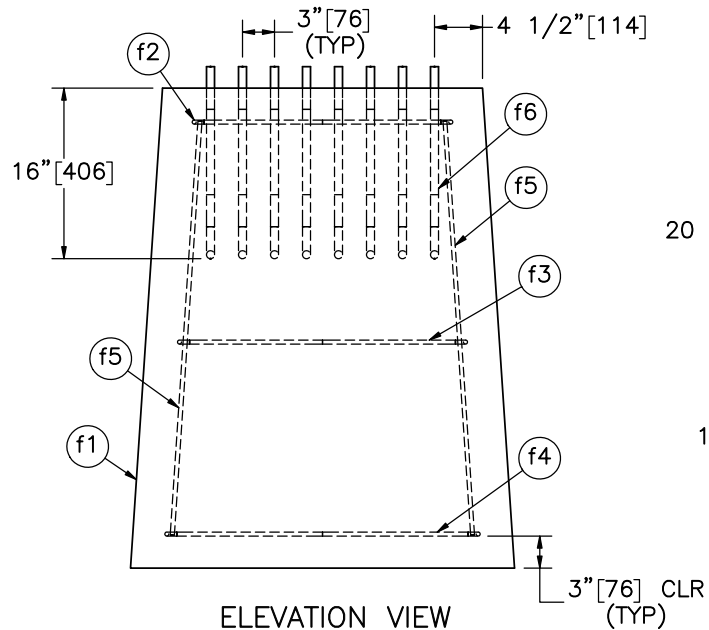

ELEVATION VIEW

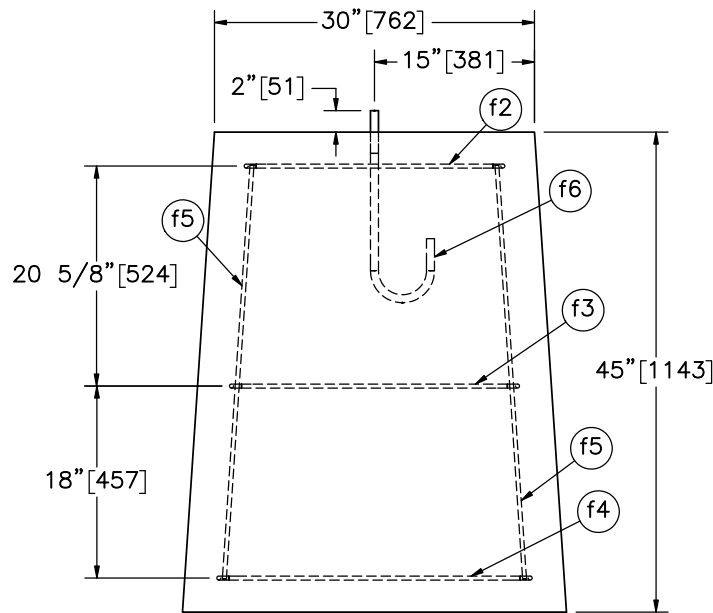

PROFILE VIEW

Item No.	QTY.	Description	Material Specification	Treatment Specification
-	1	Downstream Anchor Assembly	-	-
f1	1	Concrete	Pre-Cast Class A* Min. $f'_c = 3,000$ psi [20.7 MPa] NE Mix 47BD	-
f2	1	#3 [10] Bar, 106 5/8" [2,708] Long Unbent	ASTM A615 Gr. 60 or A996 Gr. 60	Epoxy-Coated (ASTM A775 or A934) **
f3	1	#3 [10] Bar, 117 5/8" [2,988] Long Unbent	ASTM A615 Gr. 60 or A996 Gr. 60	Epoxy-Coated (ASTM A775 or A934) **
f4	1	#3 [10] Bar, 127 1/8" [3,229] Long Unbent	ASTM A615 Gr. 60 or A996 Gr. 60	Epoxy-Coated (ASTM A775 or A934) **
f5	4	#3 [10] Bar, 39" [991] Long	ASTM A615 Gr. 60 or A996 Gr. 60	Epoxy-Coated (ASTM A775 or A934) **
f6	8	3/4" [19] Dia. UNC, Hooked Anchor J-Bolt and Nut	J-Bolt - ASTM A307 Gr. C Nut - ASTM A563DH	ASTM A153 or B695 Class 55 or F2329

* If cast in place, follow Section 501 - Portland Cement Concrete - General of the NY state standards.

** Epoxy-coating not necessary for testing purposes.



Midwest Roadside
Safety Facility

NY Box Beam to Weak Post
W-Beam Transition
Test No. NYBWT-2

Downstream Anchor Assembly

DWG. NAME:
NYBWT-2_R2

SCALE: 1:18
UNITS: in.[mm]

SHEET:
12 of 34

DATE:
10/27/2023

DRAWN BY:
JEK/JRD/JJO

REV. BY:
KAL

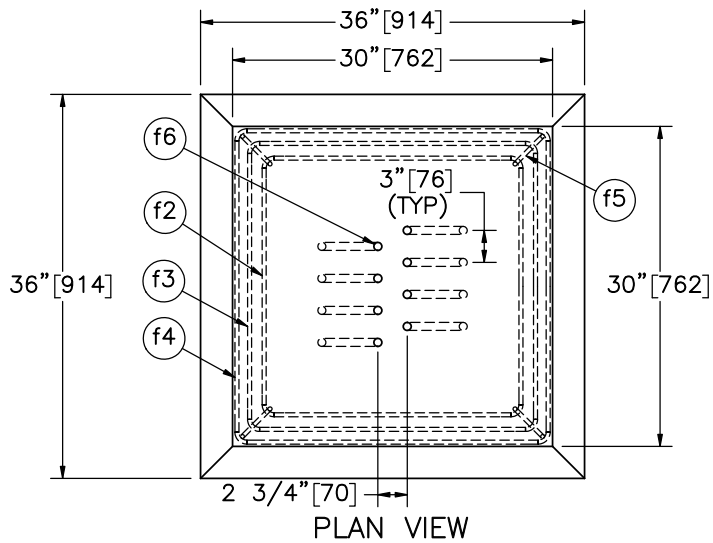

Item No.	QTY.	Description	Material Specification	Treatment Specification
-	1	Transition Anchor Assembly	-	-
f1	1	Concrete	Pre-Cast Class A* Min. $f'_c = 3,000$ psi [20.7 MPa] NE Mix 47BD	-
f2	1	#3 [10] Bar, 106 5/8" [2,708] Long Unbent	ASTM A615 Gr. 60 or A996 Gr. 60	Epoxy-Coated (ASTM A775 or A934) **
f3	1	#3 [10] Bar, 117 5/8" [2,988] Long Unbent	ASTM A615 Gr. 60 or A996 Gr. 60	Epoxy-Coated (ASTM A775 or A934) **
f4	1	#3 [10] Bar, 127 1/8" [3,229] Long Unbent	ASTM A615 Gr. 60 or A996 Gr. 60	Epoxy-Coated (ASTM A775 or A934) **
f5	4	#3 [10] Bar, 39" [991] Long	ASTM A615 Gr. 60 or A996 Gr. 60	Epoxy-Coated (ASTM A775 or A934) **
f6	8	3/4" [19] Dia. UNC, Hooked Anchor J-Bolt and Nut	J-Bolt - ASTM A307 Gr. C Nut - ASTM A563DH	ASTM A153 or B695 Class 55 or F2329

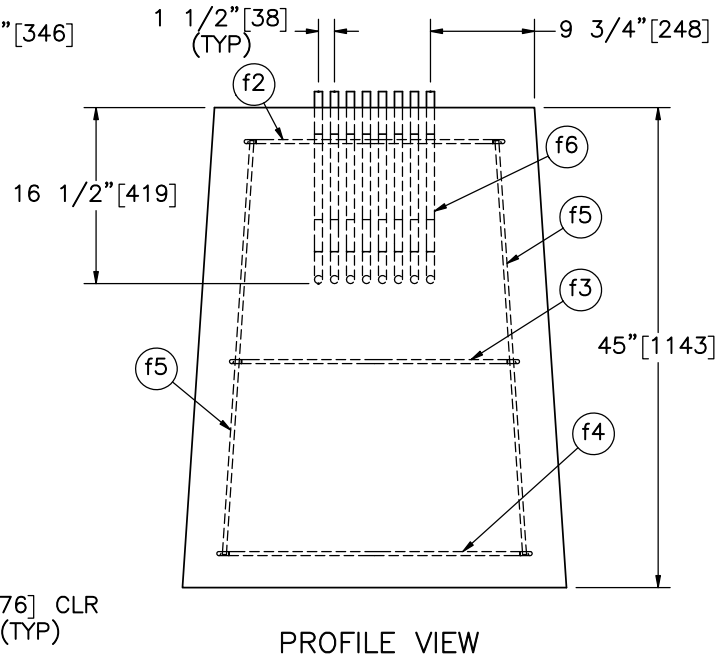
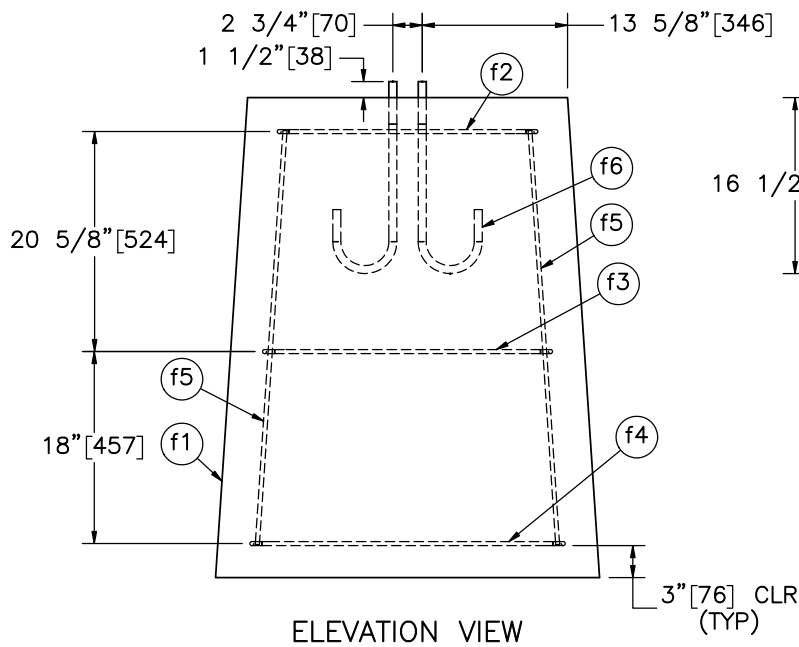

* If cast in place, follow Section 501 - Portland Cement Concrete - General of the NY state standards.
 ** Epoxy-coating not necessary for testing purposes.



Midwest Roadside Safety Facility

NY Box Beam to Weak Post
 W-Beam Transition
 Test No. NYBWT-2

Transition Anchor Assembly

DWG. NAME:
 NYBWT-2_R2

SCALE: 1:18
 UNITS: in.[mm]

SHEET:
 13 of 34

DATE:
 10/27/2023

DRAWN BY:
 JEK/JRD/JJO

REV. BY:
 KAL

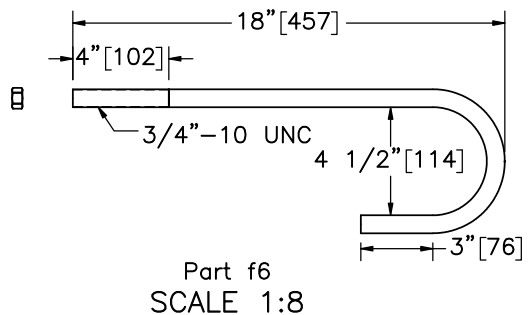
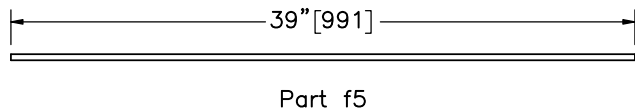
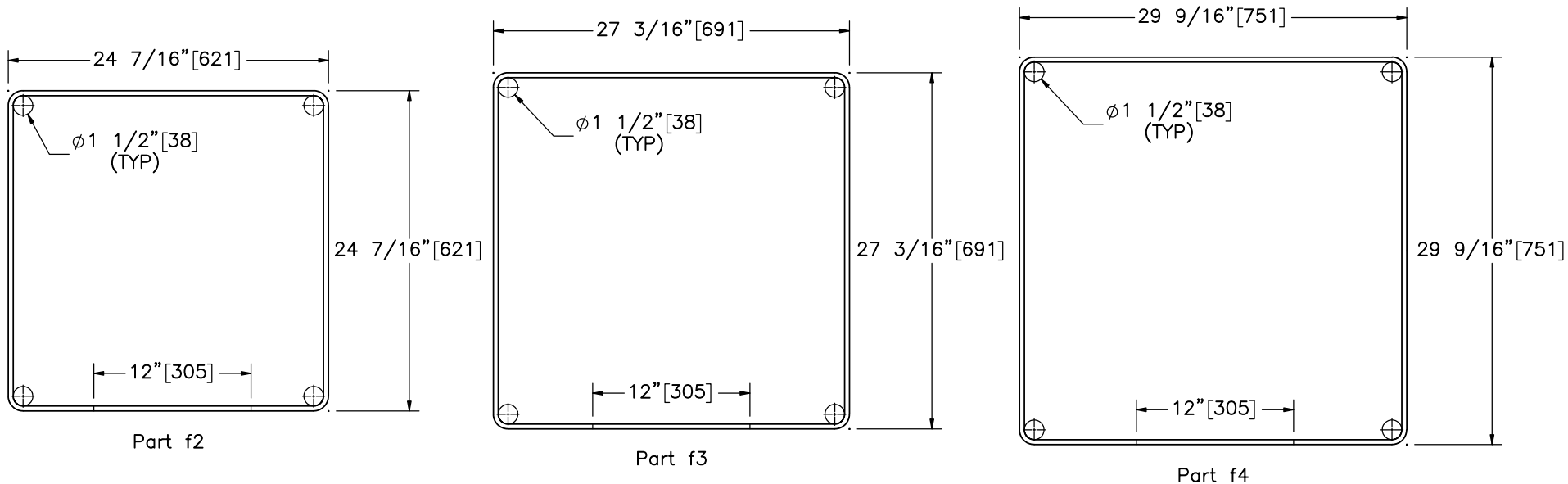

Note: (1) Epoxy-coating not necessary for testing purposes.

Bill of Bars

Bar	QTY. (Per Anchor)	Size	Total Unbent Length	Material	Treatment
f2	1	#3 [10]	106 5/8"[2,708]	ASTM A615 Gr. 60 or A996 Gr. 60	Epoxy-Coated (ASTM A775 or A934)
f3	1	#3 [10]	117 5/8"[2,988]	ASTM A615 Gr. 60 or A996 Gr. 60	Epoxy-Coated (ASTM A775 or A934)
f4	1	#3 [10]	127 1/8"[3,229]	ASTM A615 Gr. 60 or A996 Gr. 60	Epoxy-Coated (ASTM A775 or A934)
f5	4	#3 [10]	39"[991]	ASTM A615 Gr. 60 or A996 Gr. 60	Epoxy-Coated (ASTM A775 or A934)



Midwest Roadside
Safety Facility

NY Box Beam to Weak Post

W-Beam Transition

Test No. NYBWT-2

Concrete Anchor Components

DWG. NAME:
NYBWT-2_R2

SCALE: 1:12
UNITS: in.[mm]

SHEET:
14 of 34

DATE:
10/27/2023

DRAWN BY:
JEK/JRD/JJ
O

REV. BY:
KAL

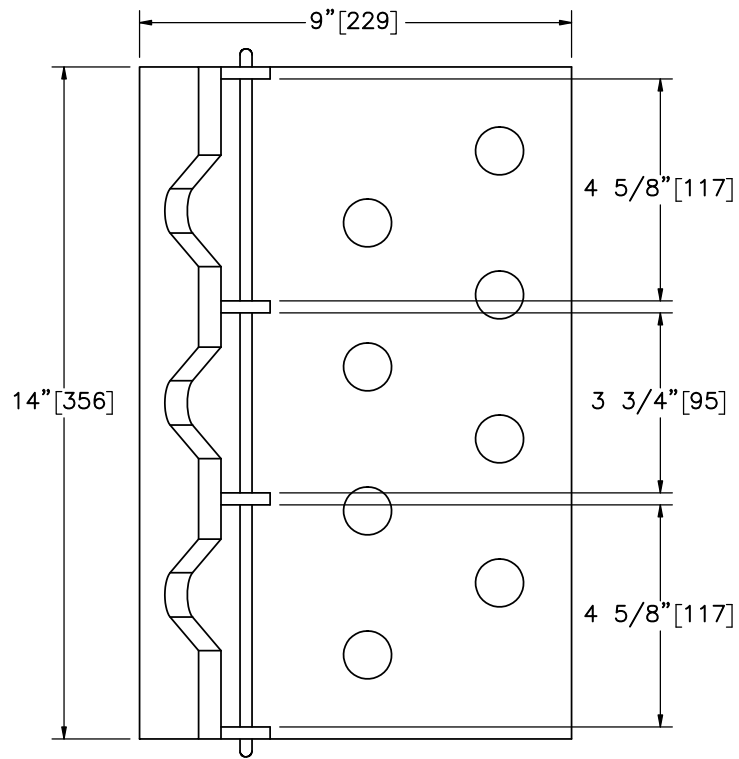

PLAN VIEW

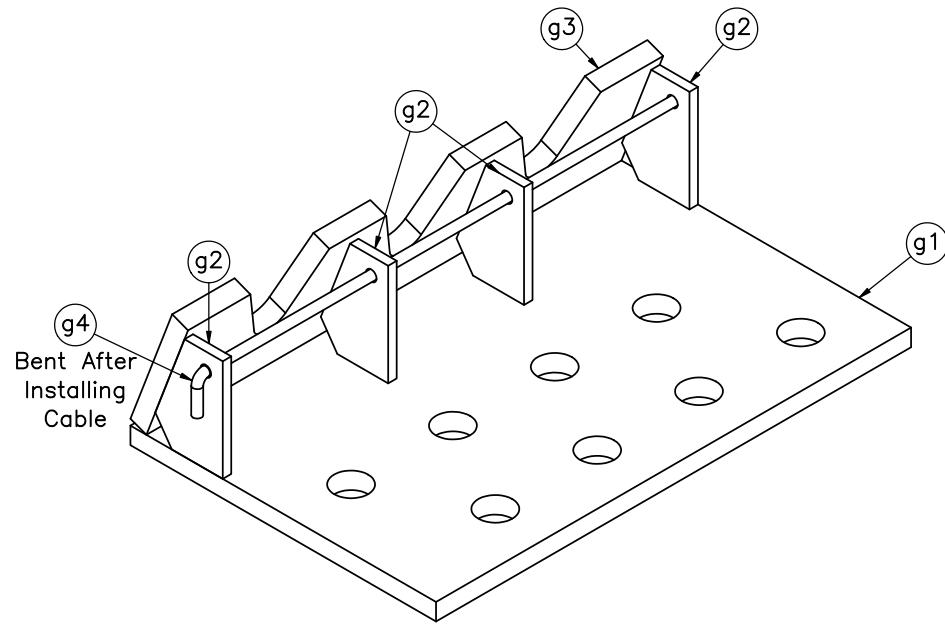

ISOMETRIC VIEW

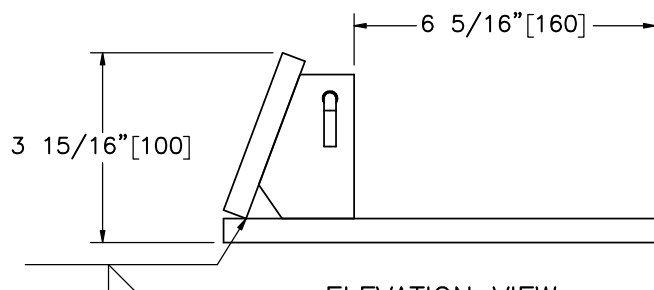

ELEVATION VIEW

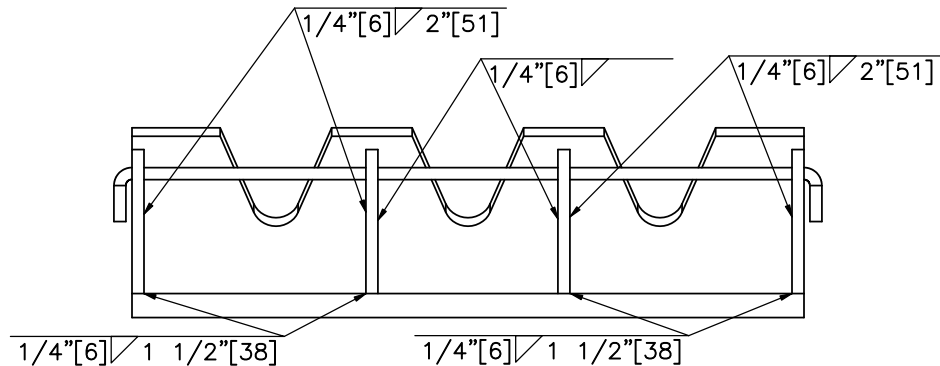

PROFILE VIEW

Item No.	QTY.	Description	Material Specification	Treatment Specification			SHEET: 15 of 34
-	1	Transition Cable Bracket Assembly	-	ASTM A123		NY Box Beam to Weak Post W-Beam Transition Test No. NYBWT-2	DATE: 10/27/2023
g1	1	14"x9"x1/2" [356x229x13] Cable Anchor Base Plate	ASTM A36	-		Midwest Roadside Safety Facility	Transition Cable Bracket Assembly
g2	4	3"x2"x1/4" [76x51x6] Cable Anchor Gusset	ASTM A36	-	DWG. NAME: NYBWT-2_R2		SCALE: 1:4 UNITS: in.[mm]
g3	1	14"x3 1/2"x1/2" [356x89x13] Cable Anchor Top Plate	ASTM A36	-			

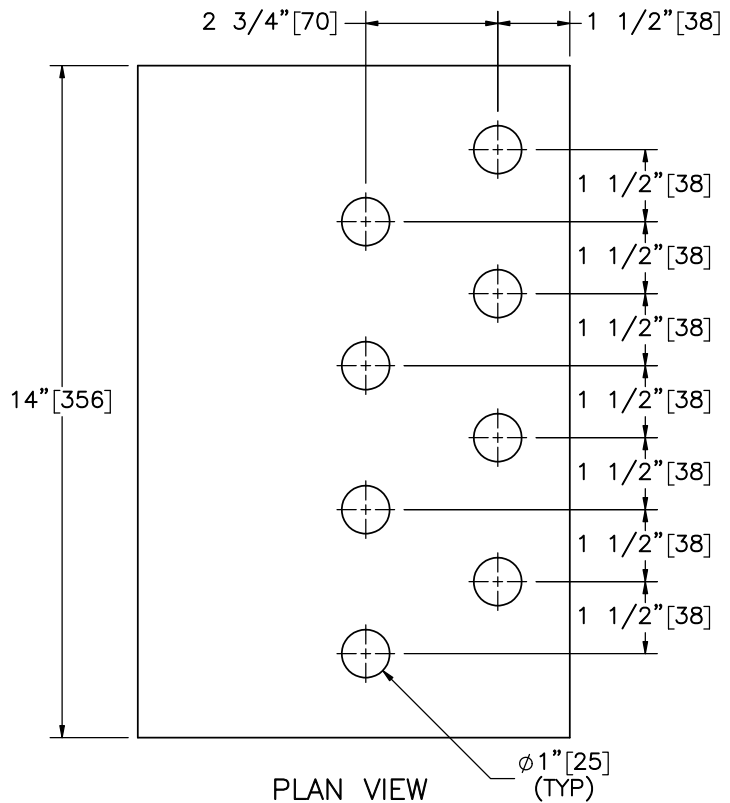

PLAN VIEW

$\phi 1'' [25]$
(TYP)

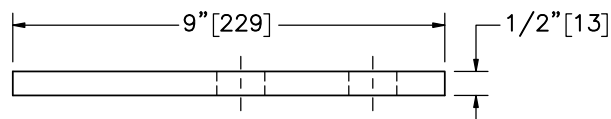

ELEVATION VIEW

Part g1

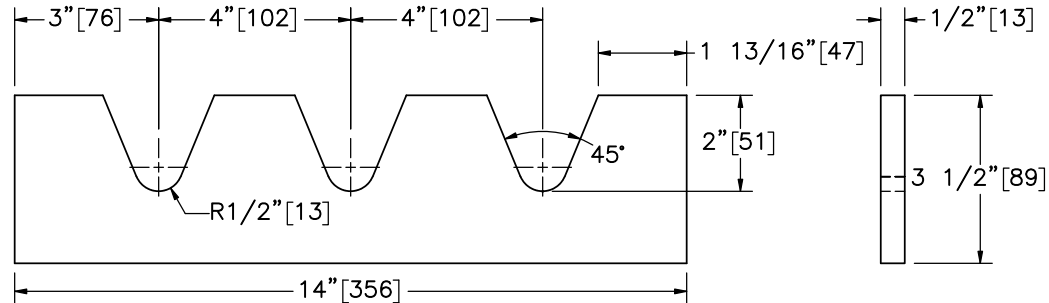

ELEVATION VIEW

PROFILE VIEW

Part g3

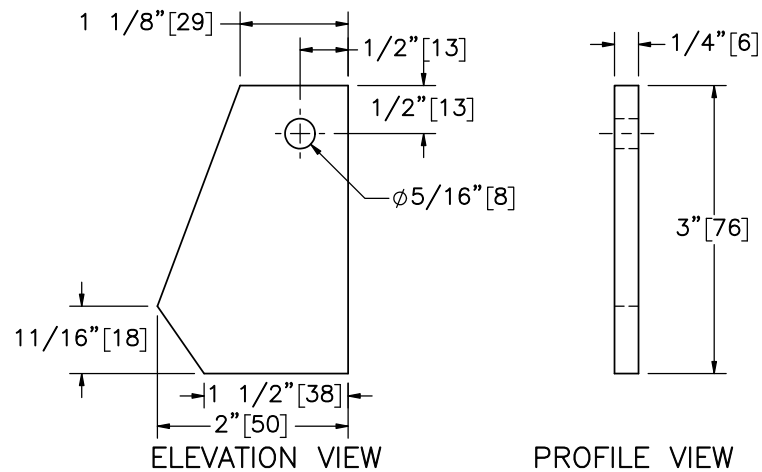

ELEVATION VIEW

PROFILE VIEW

Part g2
SCALE 1:2

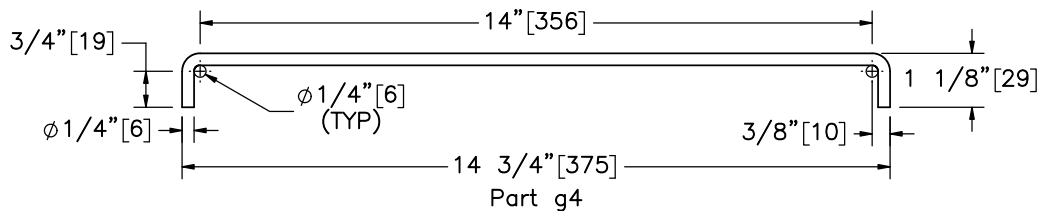

Part g4

Note: (1) Part g4 total unbent length is 16 3/8" [416]. Bend after installation.



Midwest Roadside
Safety Facility

NY Box Beam to Weak Post
W-Beam Transition
Test No. NYBWT-2

Transition Cable Bracket
Components

DWG. NAME:
NYBWT-2_R2

SCALE: 1:4
UNITS: in.[mm]

SHEET:
16 of 34

DATE:
10/27/2023

DRAWN BY:
JEK/JRD/JJ
O

REV. BY:
KAL

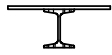

PLAN VIEW

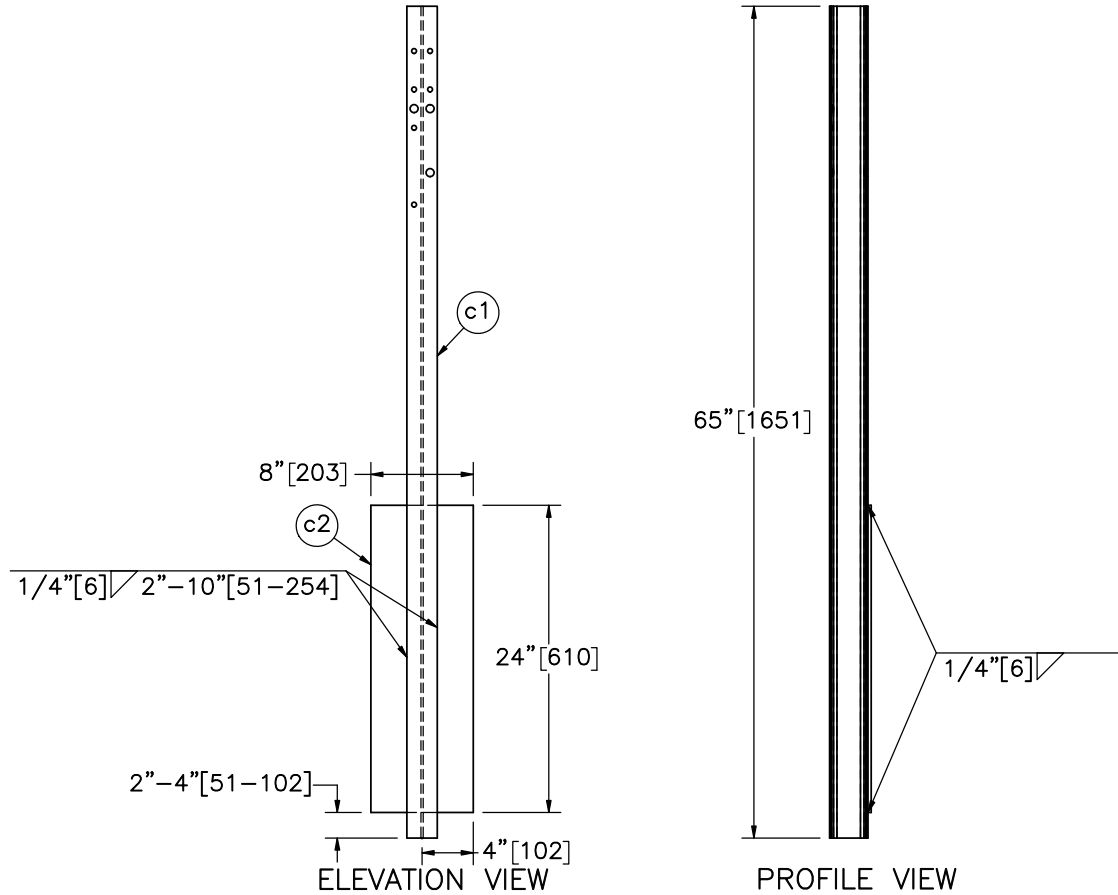

Post Assembly

Item No.	QTY.	Description	Material Specification	Treatment Specification
-	33	Post Assembly	-	ASTM A123
c2	1	24"x8"x1/4" [610x203x6] Soil Plate	ASTM A36	-
c1	1	S3x5.7 [S75x8.5], 65" [1,651] Long Post	ASTM A36	-



Midwest Roadside Safety Facility

NY Box Beam to Weak Post
 W-Beam Transition
 Test No. NYBWT-2
 Post Assemblies

DWG. NAME:
 NYBWT-2_R2

SCALE: 1:15
 UNITS: in.[mm]

SHEET:
 17 of 34

DATE:
 10/27/2023

DRAWN BY:
 JEK/JRD/JJO

REV. BY:
 KAL

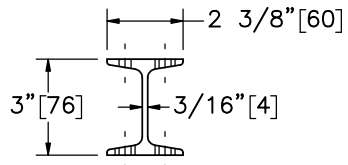

PLAN VIEW

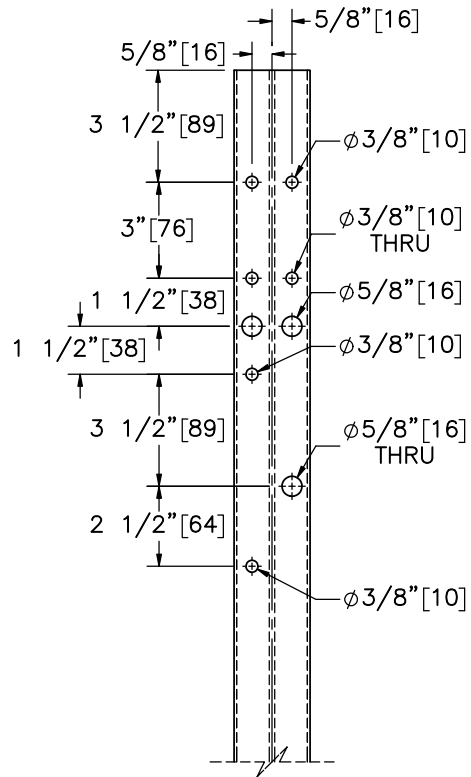

ELEVATION VIEW

Part c1

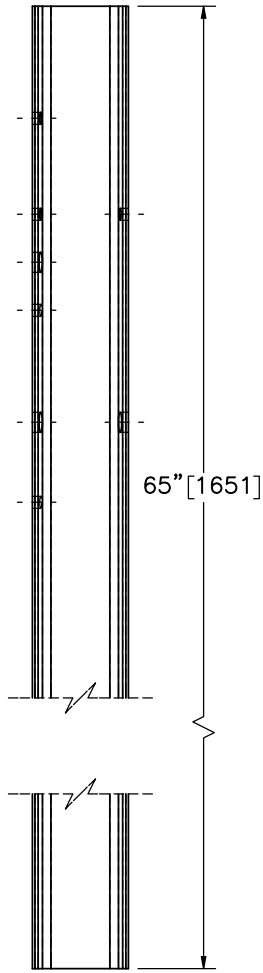

PROFILE VIEW

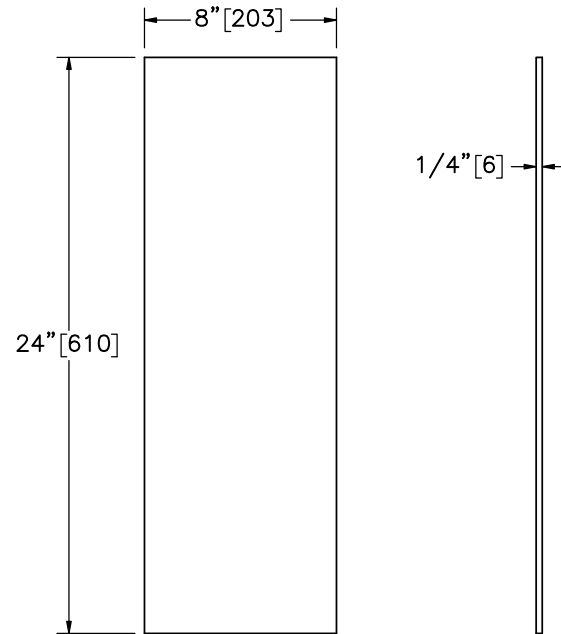

ELEVATION VIEW

PROFILE VIEW

Part c2
SCALE 1:8



Midwest Roadside
Safety Facility

NY Box Beam to Weak Post
W-Beam Transition
Test No. NYBWT-2

Post Components

DWG. NAME:
NYBWT-2_R2

SCALE: 1:6
UNITS: in.[mm]

SHEET:
18 of 34

DATE:
10/27/2023

DRAWN BY:
JEK/JRD/JJ
O

REV. BY:
KAL

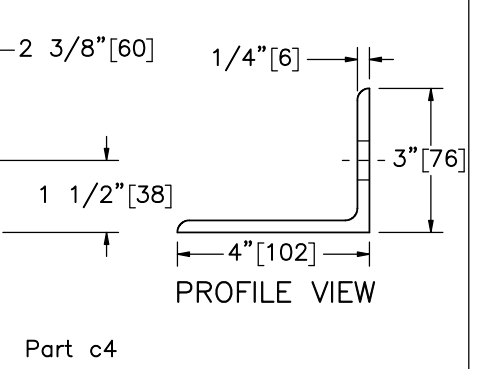
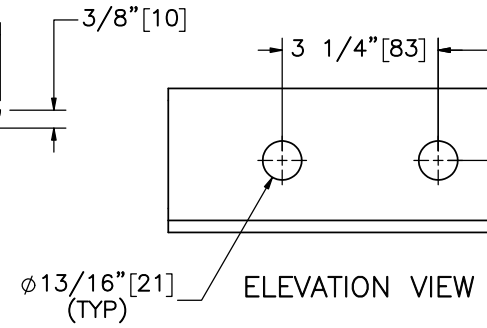
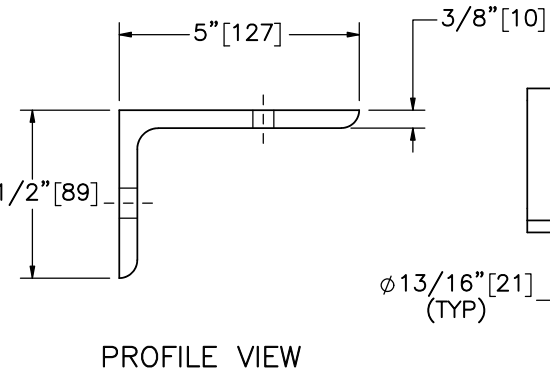
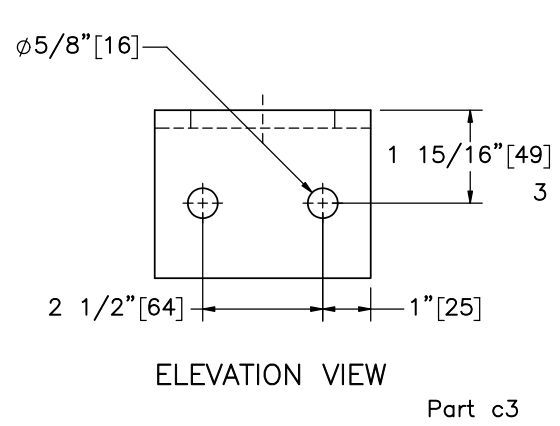
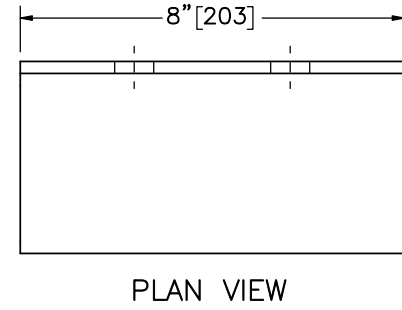
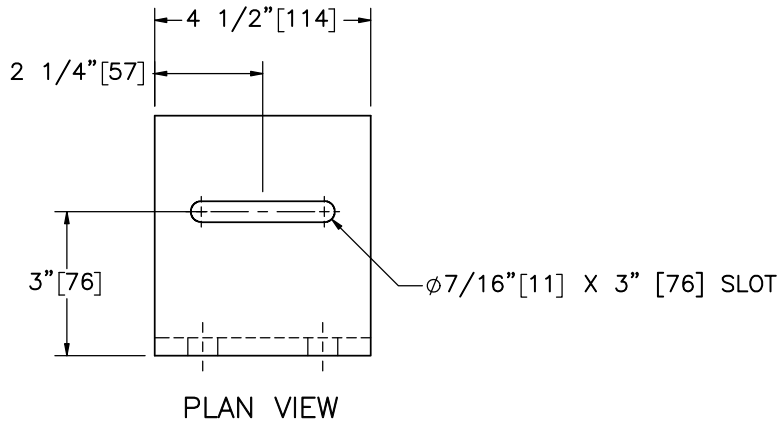

	NY Box Beam to Weak Post W-Beam Transition Test No. NYBWT-2	SHEET: 19 of 34
	Post Components	DATE: 10/27/2023
Midwest Roadside Safety Facility	DWG. NAME: NYBWT-2_R2	DRAWN BY: JEK/JRD/JJ O
	SCALE: 1:4 UNITS: in.[mm]	REV. BY: KAL

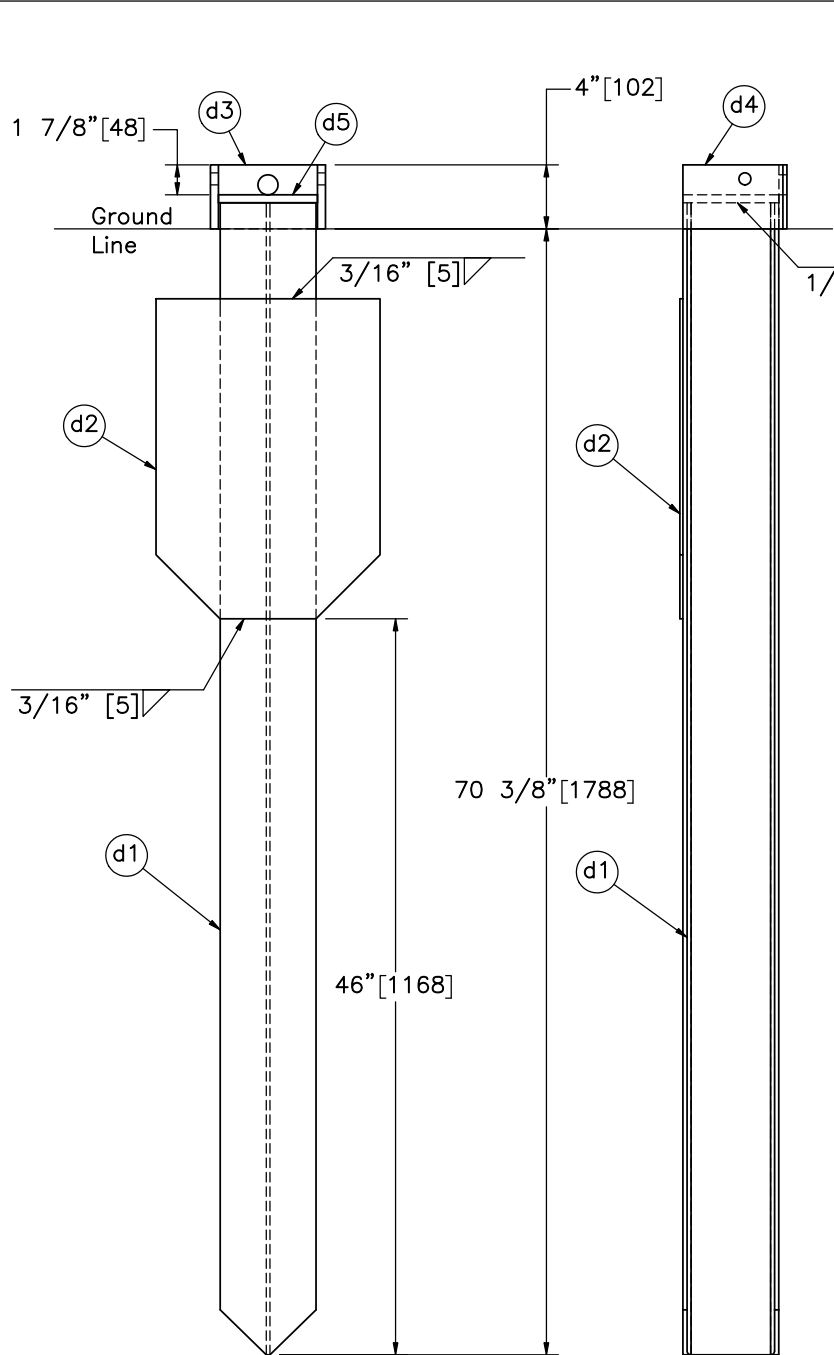

ELEVATION VIEW

PROFILE VIEW

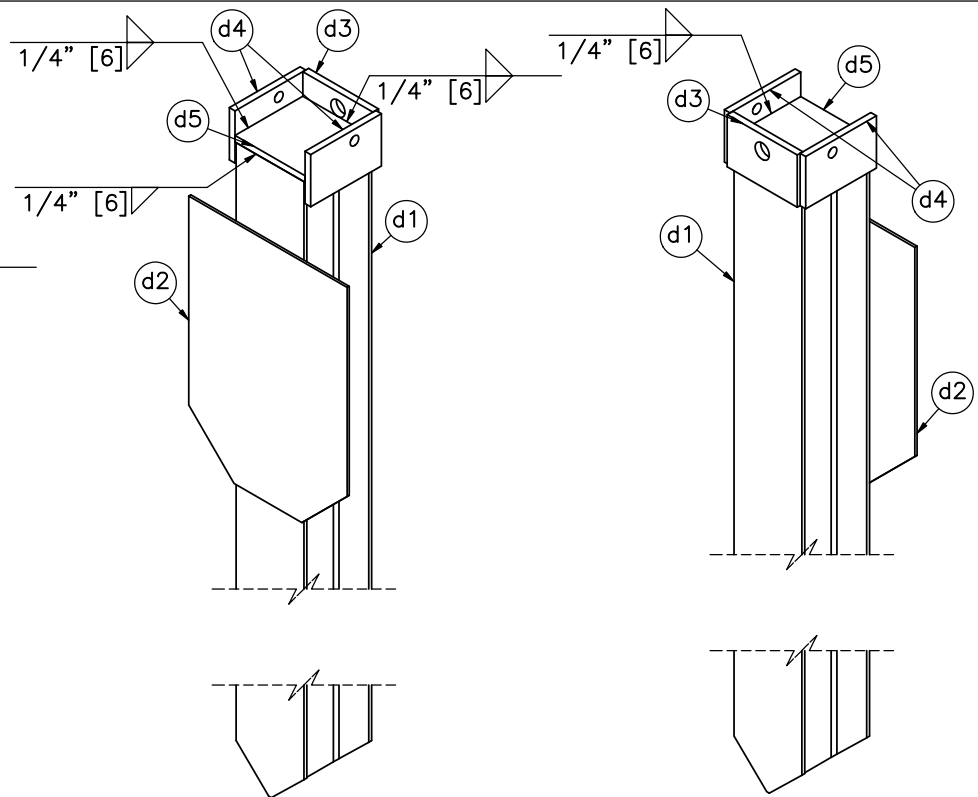

ISOMETRIC VIEWS

Item No.	QTY.	Description	Material Specification	Treatment Specification
-	2	Upstream Anchor Post Assembly	-	-
d1	1	W6x15 [W152x22.3], 72" [1,829] Long Post	ASTM A992 or ASTM A572 Gr. 50	-
d2	1	20"x14"x3/16" [508x356x5] Plate	ASTM A36	-
d3	1	6 3/16"x4"x1/2" [157x102x13] Plate	ASTM A36	-
d4	2	6 1/4"x4"x1/2" [159x102x13] Plate	ASTM A36	-
d5	1	6 3/16"x6"x1/2" [157x152x13] Plate	ASTM A36	-



Midwest Roadside Safety Facility

NY Box Beam to Weak Post
W-Beam Transition
Test No. NYBWT-2

Upstream Anchor Post Assembly

DWG. NAME:
NYBWT-2_R2

SCALE: 1:12
UNITS: in.[mm]

SHEET:
20 of 34

DATE:
10/27/2023

DRAWN BY:
JEK/JRD/JJO

REV. BY:
KAL

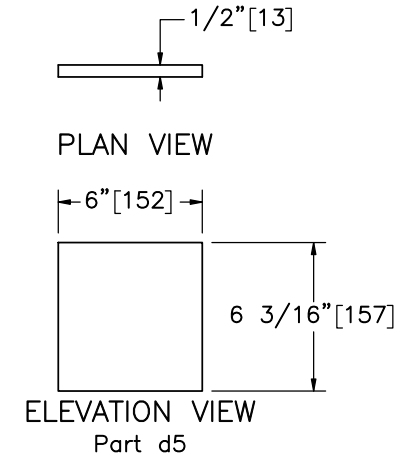
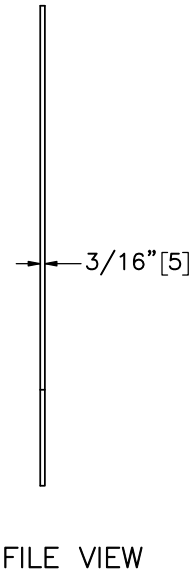
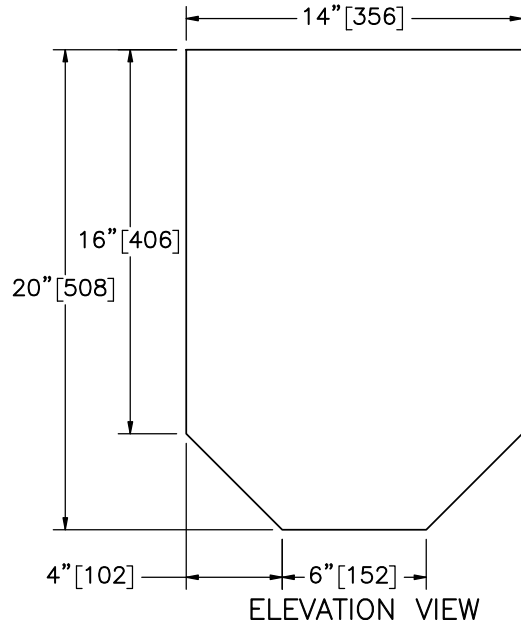
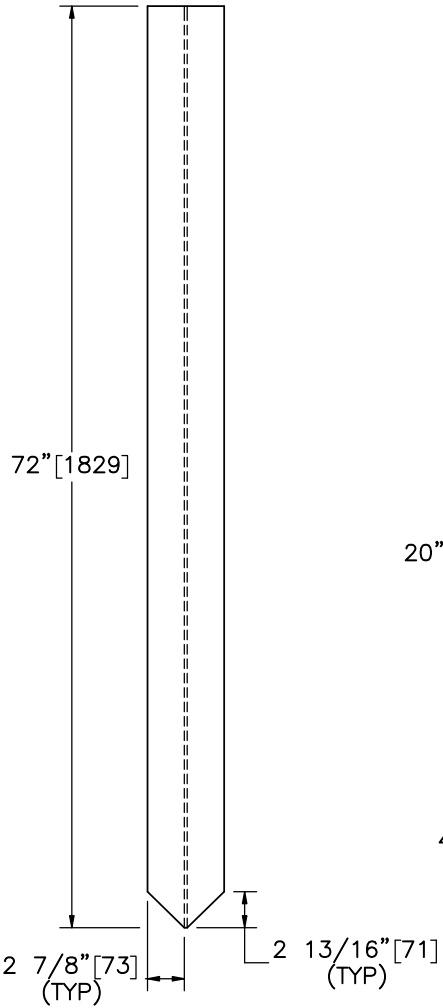
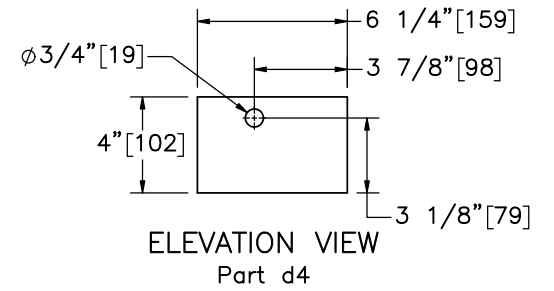
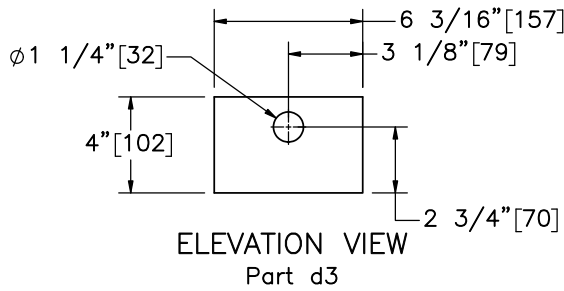
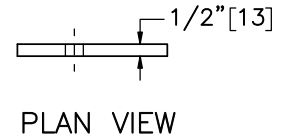
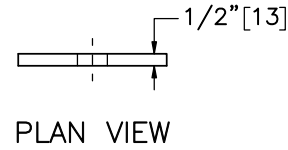
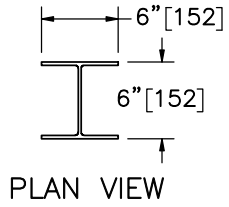

Midwest Roadside
Safety Facility

NY Box Beam to Weak Post
W-Beam Transition
Test No. NYBWT-2

Upstream Anchor Post
Components

DWG. NAME:
NYBWT-2_R2

SCALE: 1:8
UNITS: in.[mm]

SHEET:
21 of 34

DATE:
10/27/2023

DRAWN BY:
JEK/JRD/JJ
O

REV. BY:
KAL

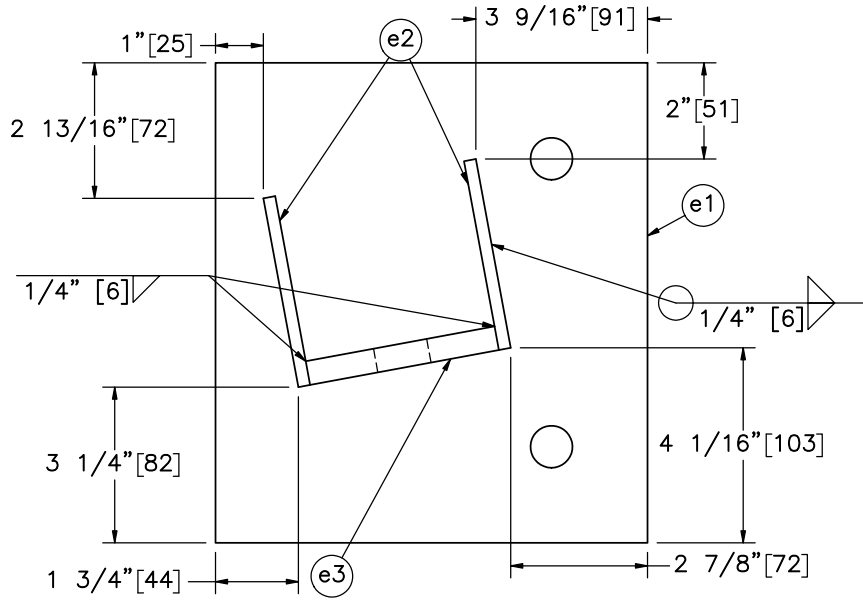

PLAN VIEW

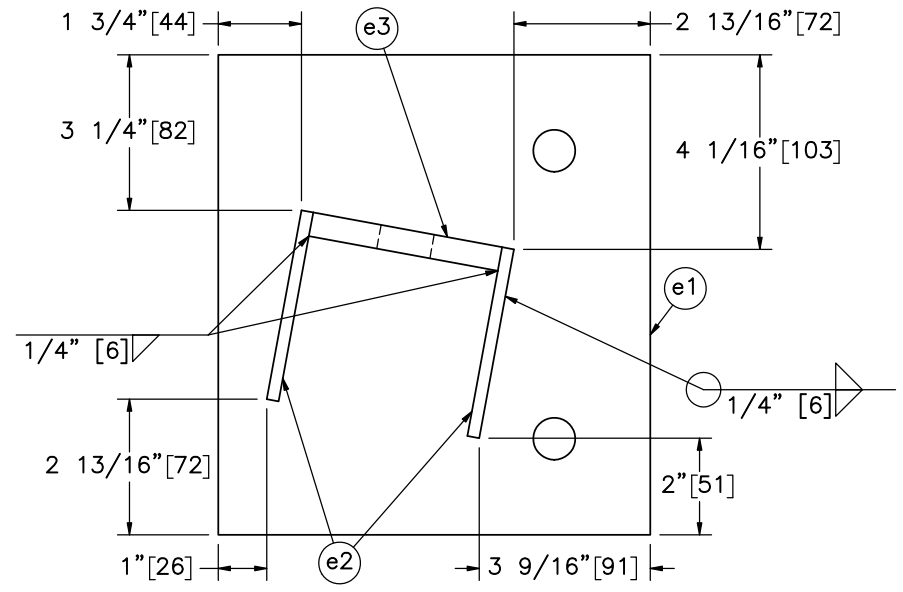

PLAN VIEW

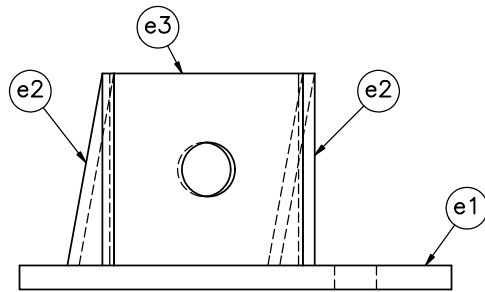

ELEVATION VIEW
Upstream Cable Anchor Assembly
Configuration A

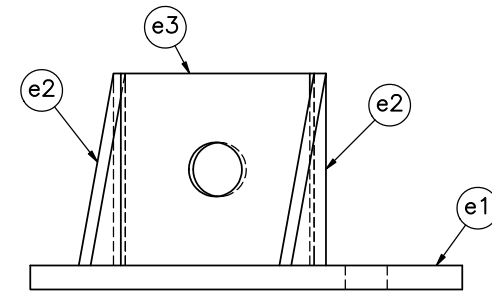

ELEVATION VIEW
Upstream Cable Anchor Assembly
Configuration B

* Galvanization not necessary for testing purposes. Can be painted or spray galvanized if desired.

Item No.	QTY.	Description	Material Specification	Treatment Specification	 NY Box Beam to Weak Post W-Beam Transition Test No. NYBWT-2 Upstream Cable Anchor Assembly Details DWG. NAME: NYBWT-2_R2	SHEET: 22 of 34	
-	1 each	Upstream Cable Anchor Assembly Configuration A-B	-	ASTM A123*			DATE: 10/27/2023
e1	1	10"x9"x1/2" [254x229x13] Box Beam Cable Anchor Base Plate	ASTM A36	-			DRAWN BY: JEK/JRD/JJO
e2	2	4"x4"x1/4" [102x102x6] Box Beam Cable Anchor Gusset	ASTM A36	-			REV. BY: KAL
e3	1	4"x4"x1/2" [102x102x13] Box Beam Cable Anchor Mounting Plate	ASTM A36	-			SCALE: 1:4 UNITS: in.[mm]

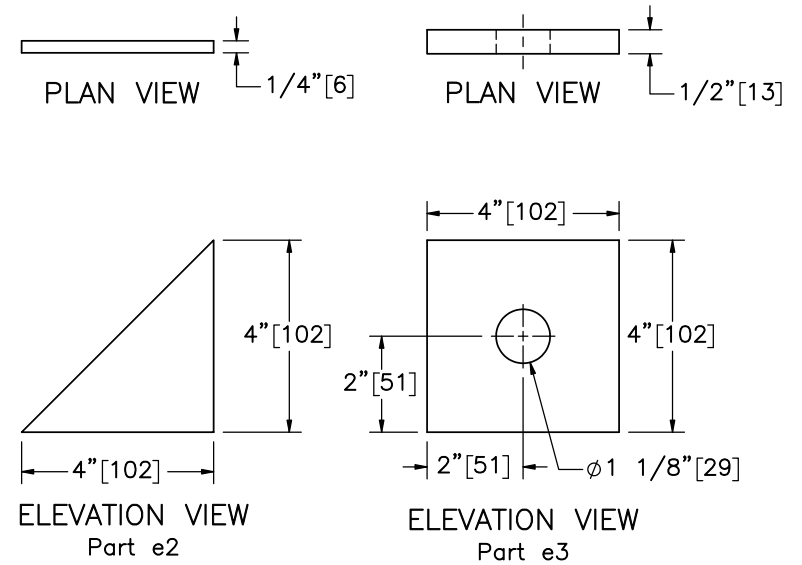
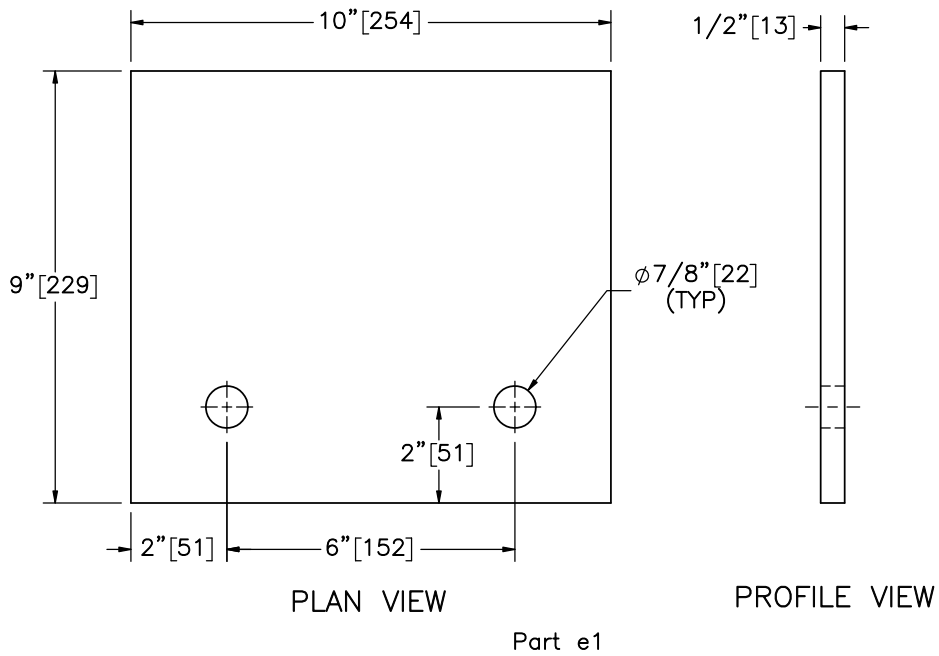

Midwest Roadside
Safety Facility

NY Box Beam to Weak Post
W-Beam Transition
Test No. NYBWT-2

Upstream Cable Anchor
Components

DWG. NAME:
NYBWT-2_R2

SCALE: 1:4
UNITS: in.[mm]

SHEET:
23 of 34

DATE:
10/27/2023

DRAWN BY:
JEK/JRD/JJ
O

REV. BY:
KAL

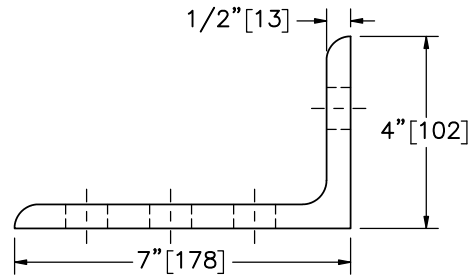

PLAN VIEW

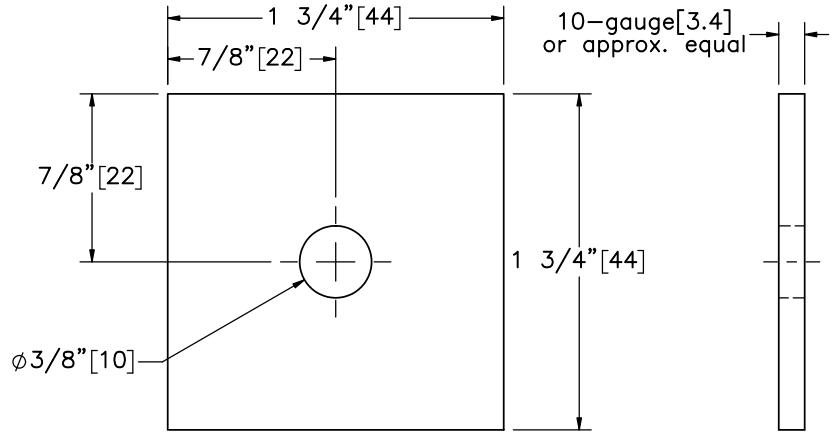

ELEVATION VIEW

PROFILE VIEW

Part i2
SCALE 1:1

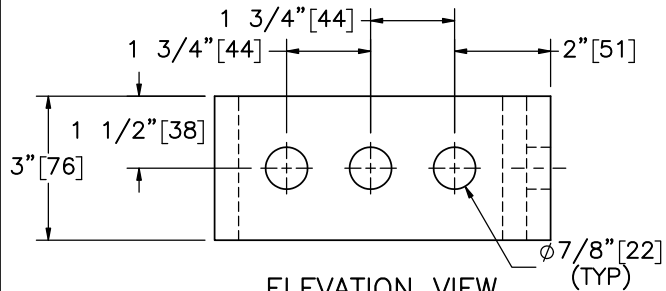

ELEVATION VIEW

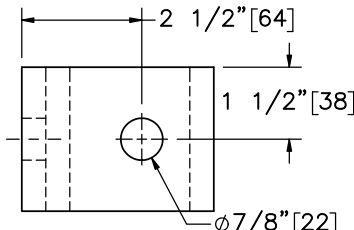

PROFILE VIEW

Part i1

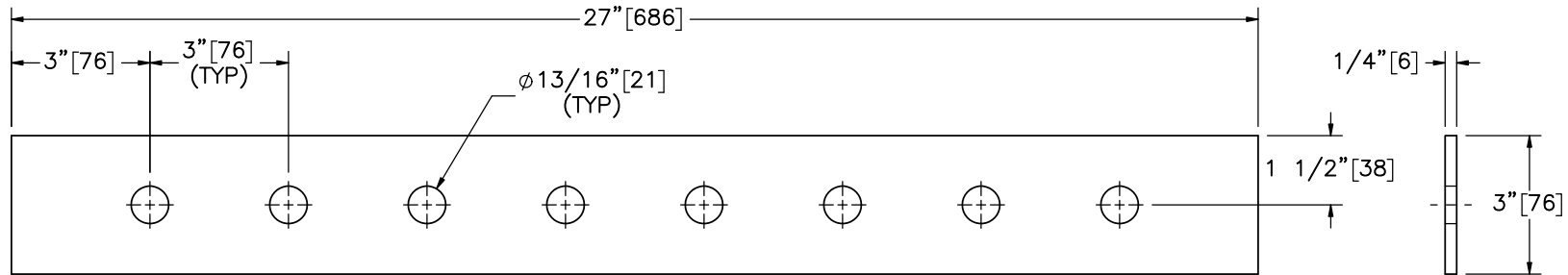

PLAN VIEW

PROFILE VIEW

Part i3



Midwest Roadside
Safety Facility

NY Box Beam to Weak Post
W-Beam Transition
Test No. NYBWT-2

Component Details

DWG. NAME.
NYBWT-2_R2

SCALE: 1:4
UNITS: in.[mm]

SHEET:
24 of 34

DATE:
10/27/2023

DRAWN BY:
JEK/JRD/JJ
O

REV. BY:
KAL

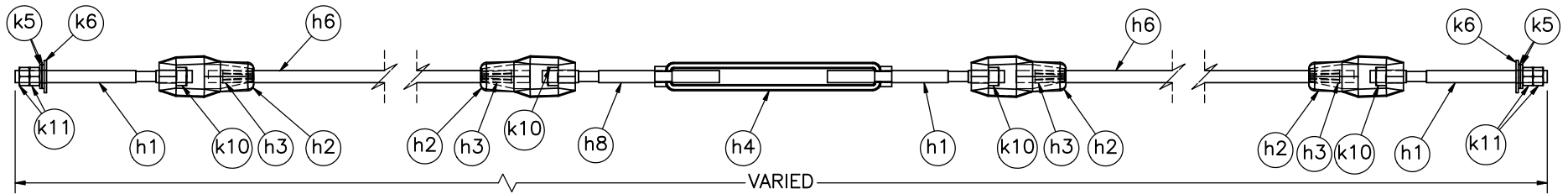

Transition Anchor Cable Assembly

Item No.	QTY.	Description	Material Specification	Treatment Specification	Hardware Guide
-	3	Transition Anchor Cable Assembly	-	-	-
h1	3	3/4" [19] Dia. UNC, 11" [279] Long Threaded Rod	ASTM A307 Gr. A or equivalent	ASTM A153 or B695 Class 55 or F2329	RCE03
h2	4	Cable End Fitting	ASTM A27 Gr. 70-40 Class 1	ASTM A153 or B695	RCE03
h3	4	Cable Wedge	ASTM A47 Gr. 32510	-	FMM01
h4	1	Crosby Threaded Turnbuckle	Stock No. 1034115	As Supplied	-
h6	2	3/4" [19] Dia. 3x7 IWRC IPS Wire Rope - Various Lengths	ASTM A741 Type 1	Class A Coating	RCM01
h8	1	3/4" [19] Dia. UNC-LH THD, 11" [279] Long Threaded Rod	ASTM A307 Gr. A or equivalent	ASTM A153 or B695 Class 55 or F2329	RCE03
k5	4	3/4" [19] Dia. Hardened Flat Washer	ASTM F436	ASTM A153 or B695 Class 55 or F1136 Gr. 3 or F2329	FWC20b
k6	2	3/4" [19] Dia. Plain Round Washer	ASTM F844	ASTM A123 or A153 or F2329	FWC20a
k10	4	3/4" [19] Dia. UNC Square Nut	ASTM A563A or equivalent	ASTM A153 or B695 Class 55 or F2329	FNS20
k11	4	3/4" [19] Dia. UNC Hex Nut	ASTM A563A or equivalent	ASTM A153 or B695 Class 55 or F2329	FNX20a

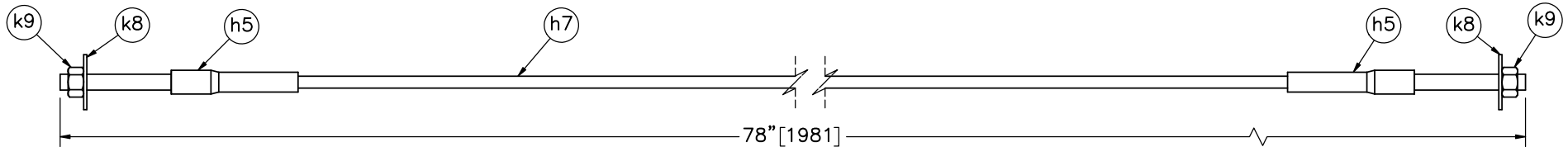

Upstream Cable Assembly

Item No.	QTY.	Description	Material Specification	Treatment Specification	Hardware Guide
-	2	Upstream Cable Assembly	-	-	-
h5	2	BCT Anchor Cable End Swaged Fitting	Fitting - ASTM A576 Gr. 1035 Stud - ASTM F568 Class C	Fitting - ASTM A153 Stud - ASTM A153 or B695	-
k9	2	1" [25] Dia. UNC Heavy Hex Nut	ASTM A563DH or equivalent	ASTM A153 or B695 Class 55 or F2329	FNX24b
k8	2	1" [25] Dia. Plain Round Washer	ASTM F844	ASTM A123 or A153 or F2329	FWC24a
h7	1	3/4" [19] Dia. 6x19 IWRC IPS Wire Rope	ASTM A741 Type 2	Class A Coating	-

Notes: (1) Total lengths of the three transition anchor cable assemblies are approximately 282" [7,163], 317" [8,052], and 352" [8,941].



Midwest Roadside Safety Facility

NY Box Beam to Weak Post
W-Beam Transition
Test No. NYBWT-2

Anchor Cable Details

DWG. NAME:
NYBWT-2_R2

SCALE: 1:10
UNITS: in.[mm]

SHEET:
25 of 34

DATE:
10/27/2023

DRAWN BY:
JEK/JRD/JJ
O

REV. BY:
KAL

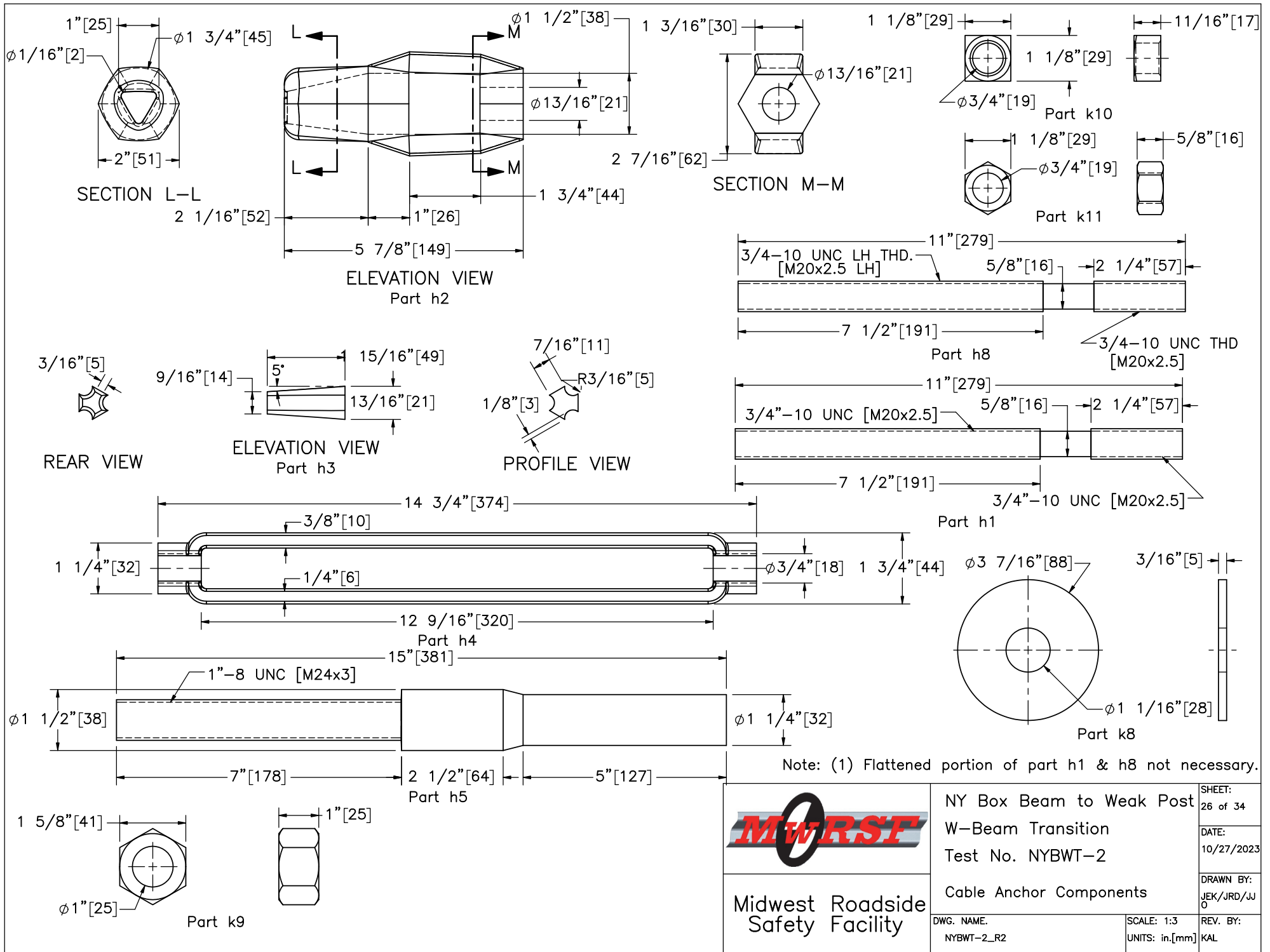

Midwest Roadside Safety Facility

NY Box Beam to Weak Post
W-Beam Transition
Test No. NYBWT-2
Cable Anchor Components

DWG. NAME:
NYBWT-2_R2

SCALE: 1:3
UNITS: in.[mm]

SHEET:
26 of 34
DATE:
10/27/2023
DRAWN BY:
JEK/JRD/JJ
O
REV. BY:
KAL

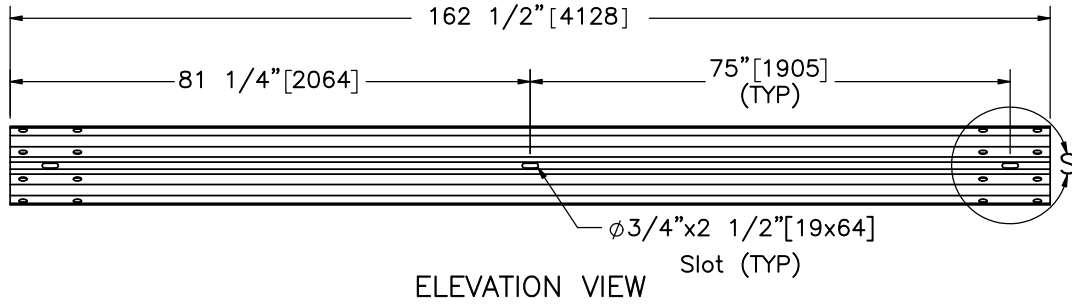

ELEVATION VIEW

Part a1

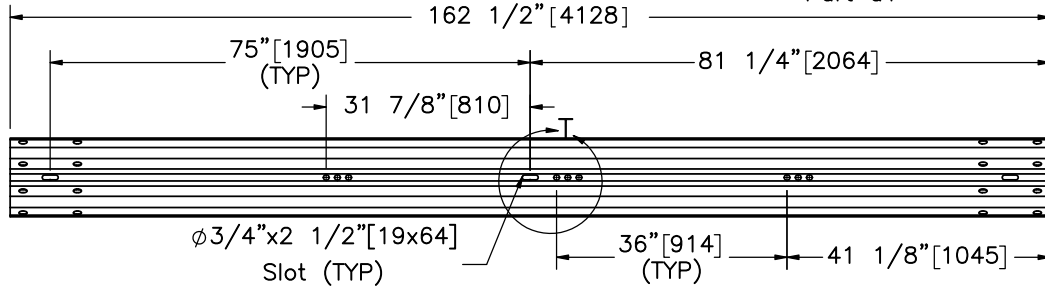

ELEVATION VIEW

Part a2

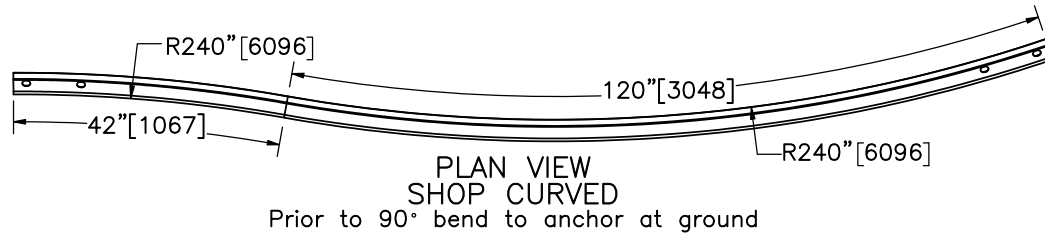

PLAN VIEW
SHOP CURVED
Prior to 90° bend to anchor at ground

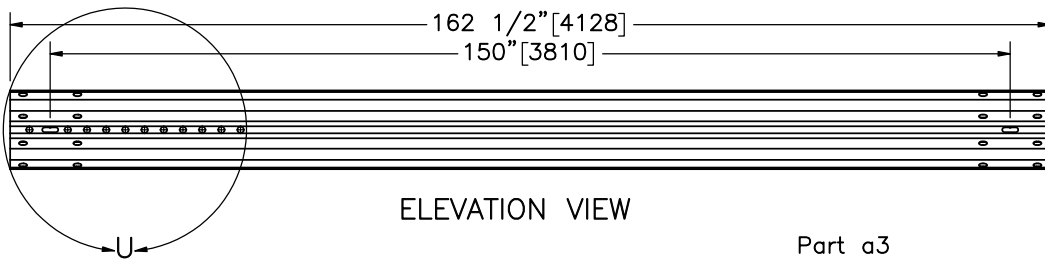

ELEVATION VIEW

Part a3

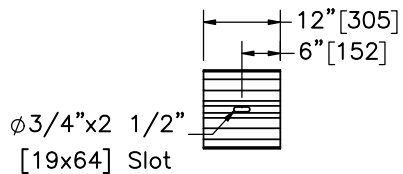

ELEVATION VIEW

PROFILE VIEW

Part a4

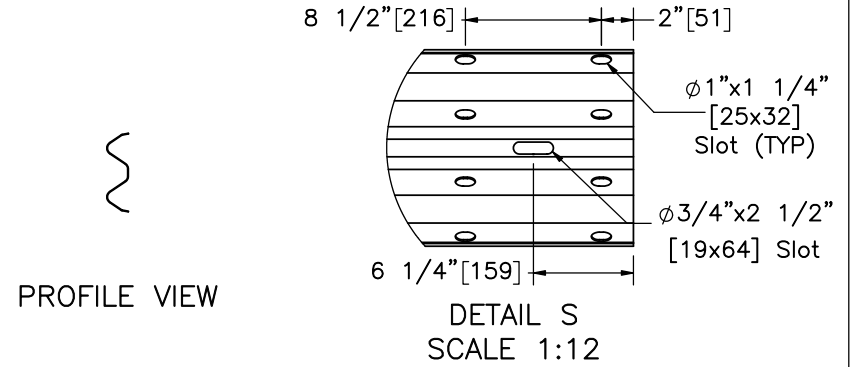

PROFILE VIEW

DETAIL S
SCALE 1:12

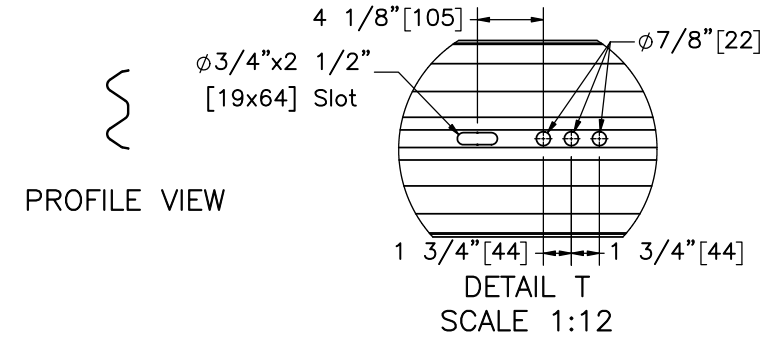

PROFILE VIEW

DETAIL T
SCALE 1:12

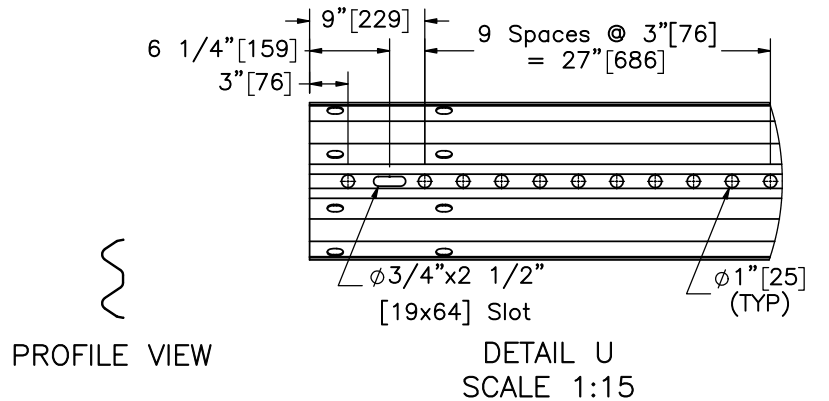

PROFILE VIEW

DETAIL U
SCALE 1:15



Midwest Roadside
Safety Facility

NY Box Beam to Weak Post

W-Beam Transition

Test No. NYBWT-2

W-Beam Rail Sections

DWG. NAME.
NYBWT-2_R2

SCALE: 1:30
UNITS: in.[mm]

SHEET:
27 of 34

DATE:
10/27/2023

DRAWN BY:
JEK/JRD/JJ
O

REV. BY:
KAL

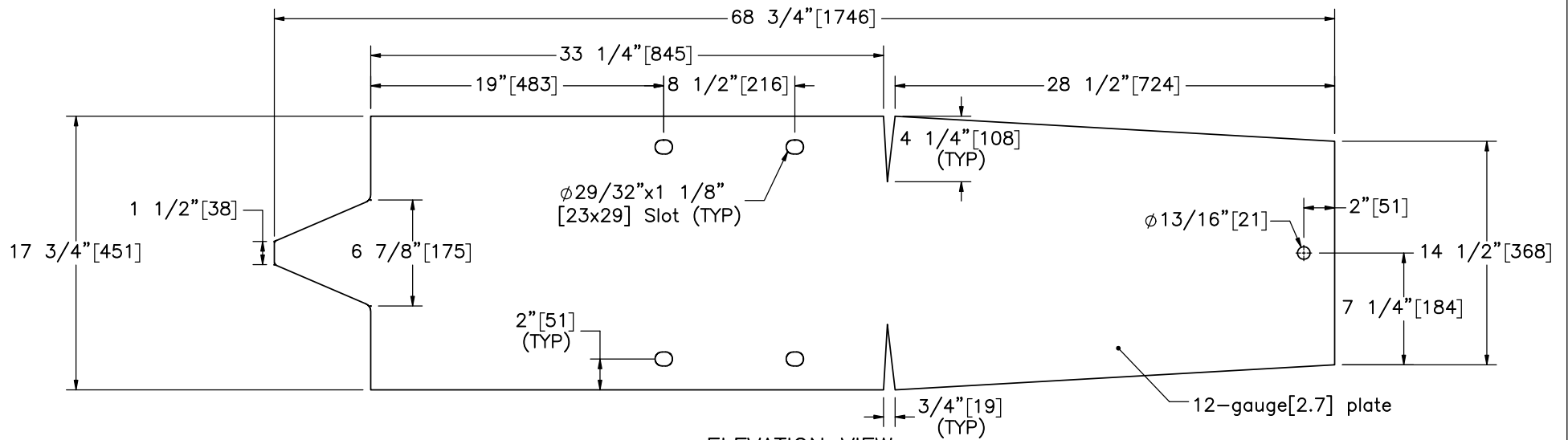

ELEVATION VIEW
FLAT PATTERN

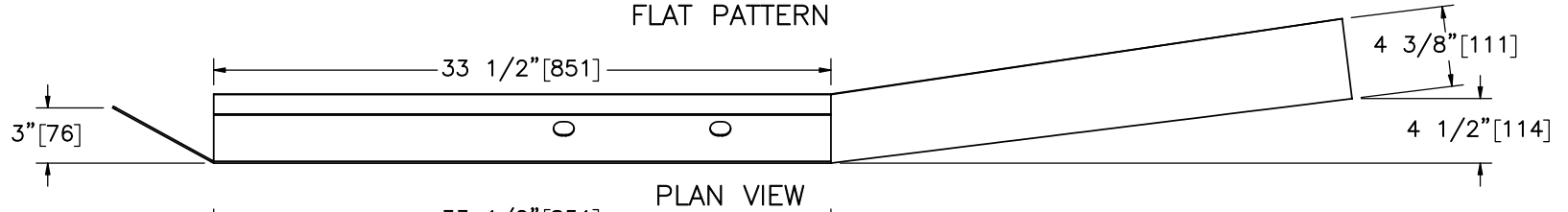

PLAN VIEW

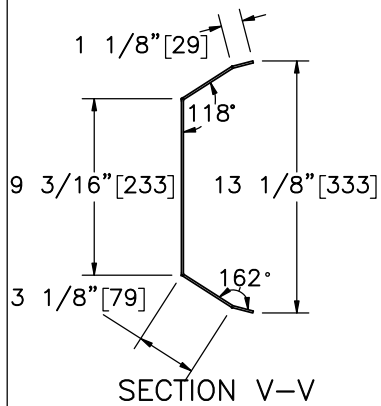

SECTION V-V

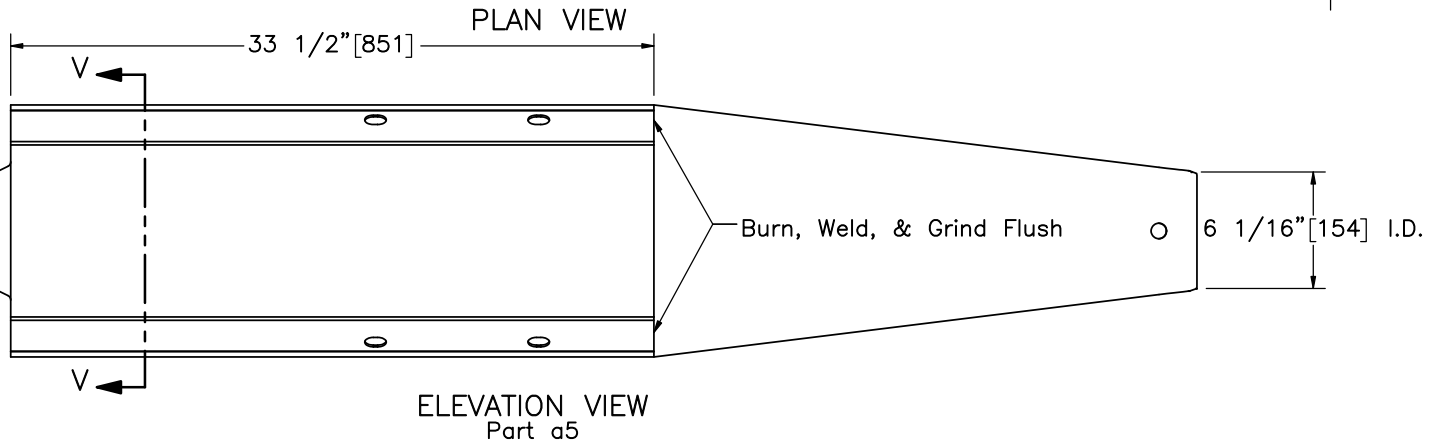

ELEVATION VIEW
Part a5



Midwest Roadside
Safety Facility

NY Box Beam to Weak Post
W-Beam Transition
Test No. NYBWT-2

W-Beam to Box Beam
Transition Cover

DWG. NAME:
NYBWT-2_R2

SCALE: 1:10
UNITS: in.[mm]

SHEET:
28 of 34

DATE:
10/27/2023

DRAWN BY:
JEK/JRD/JJ
O

REV. BY:
KAL

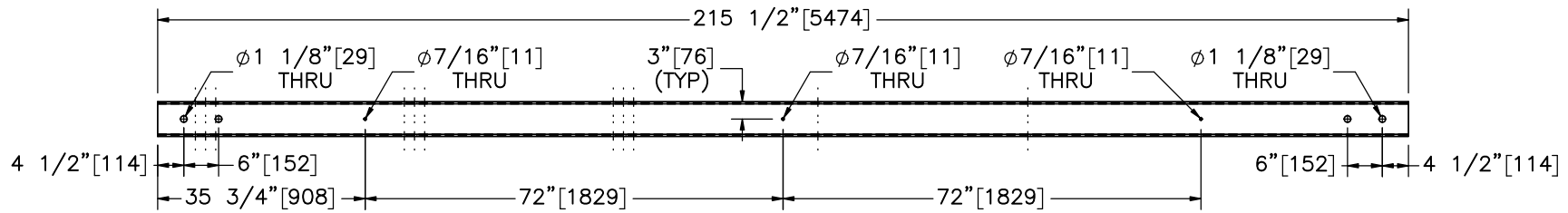

PLAN VIEW

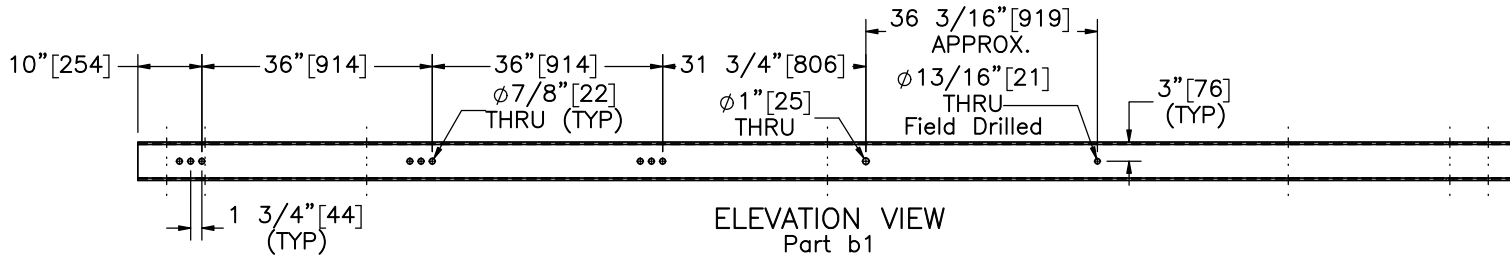

ELEVATION VIEW
Part b1

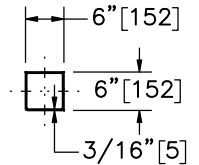

PROFILE VIEW

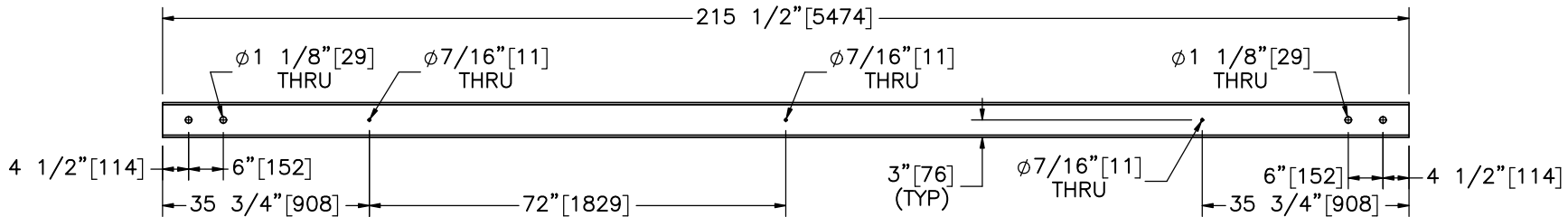

PLAN VIEW
Part b2

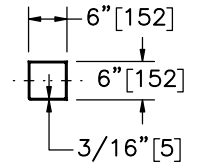

PROFILE VIEW

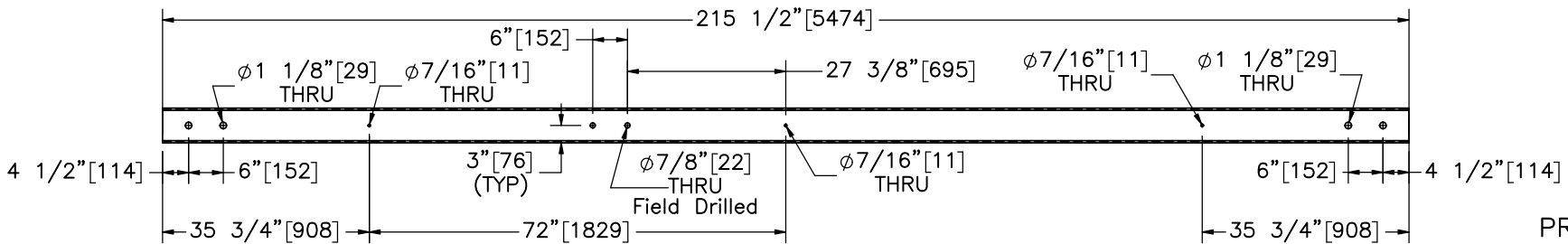

PLAN VIEW
Part b3

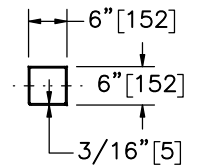

PROFILE VIEW



Midwest Roadside
Safety Facility

NY Box Beam to Weak Post
W-Beam Transition
Test No. NYBWT-2

Box Beam Rail Sections

DWG. NAME:
NYBWT-2_R2

SCALE: 1:30
UNITS: in.[mm]

SHEET:
29 of 34

DATE:
10/27/2023

DRAWN BY:
JEK/JRD/JJ
O

REV. BY:
KAL

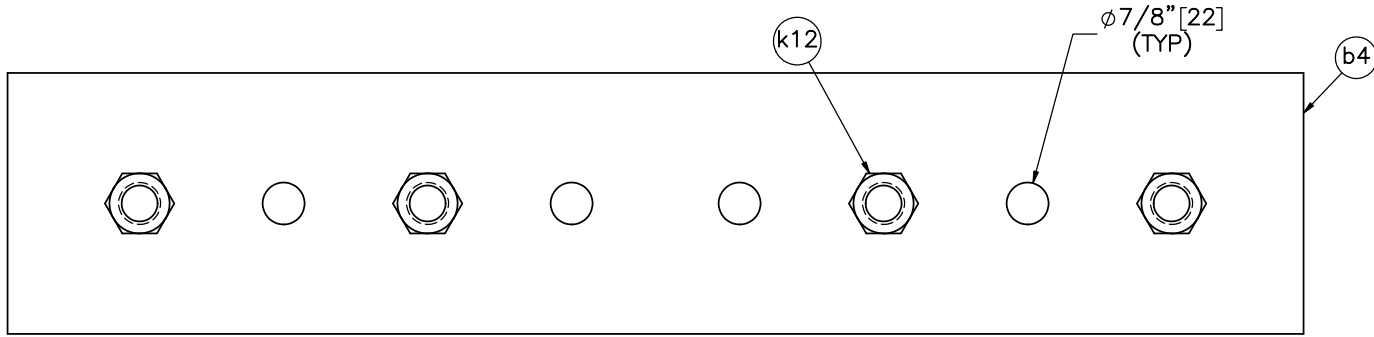

ELEVATION VIEW

Assembled Splice Plate and Nuts

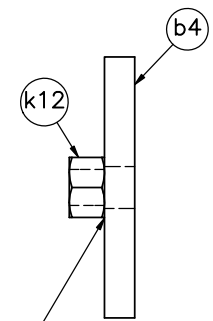

PROFILE VIEW

Tack weld all nuts to splice plates prior to assembly.

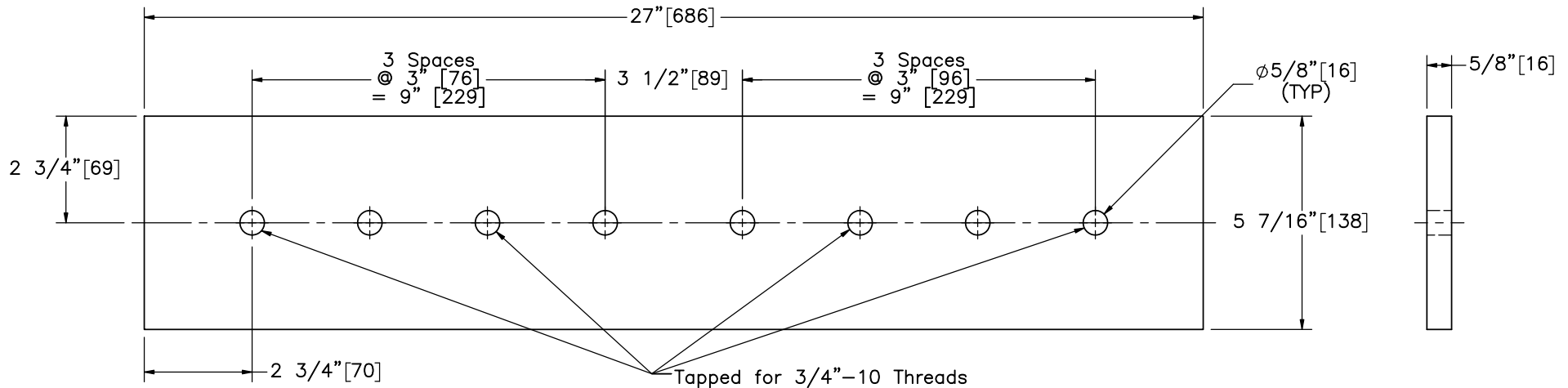

ELEVATION VIEW

Alternative Splice Plate With Tapped Holes

PROFILE VIEW

Note: Splice plate with tapped holes may be used instead of splice plate with tack welded nuts.

Item No.	QTY.	Description	Material Specification	Treatment Specification	Hardware Guide	 Midwest Roadside Safety Facility	NY Box Beam to Weak Post W-Beam Transition		SHEET: 30 of 34
-	10	Splice Plate with Tack Welded Nuts	-	ASTM A123	-		Test No. NYBWT-2	Box Beam Splice Plate Details	
b4	1	27"x5 7/16"x5/8" [686x138x16] Splice Plate	ASTM A36	-	-	DWG. NAME: NYBWT-2_R2 SCALE: 1:4 UNITS: in.[mm]	DRAWN BY: JEK/JRD/JJO		REV. BY: KAL
k12	4	3/4" [19] Dia. UNC Heavy Hex Nut	ASTM A563DH or equivalent	-	FNX20b				

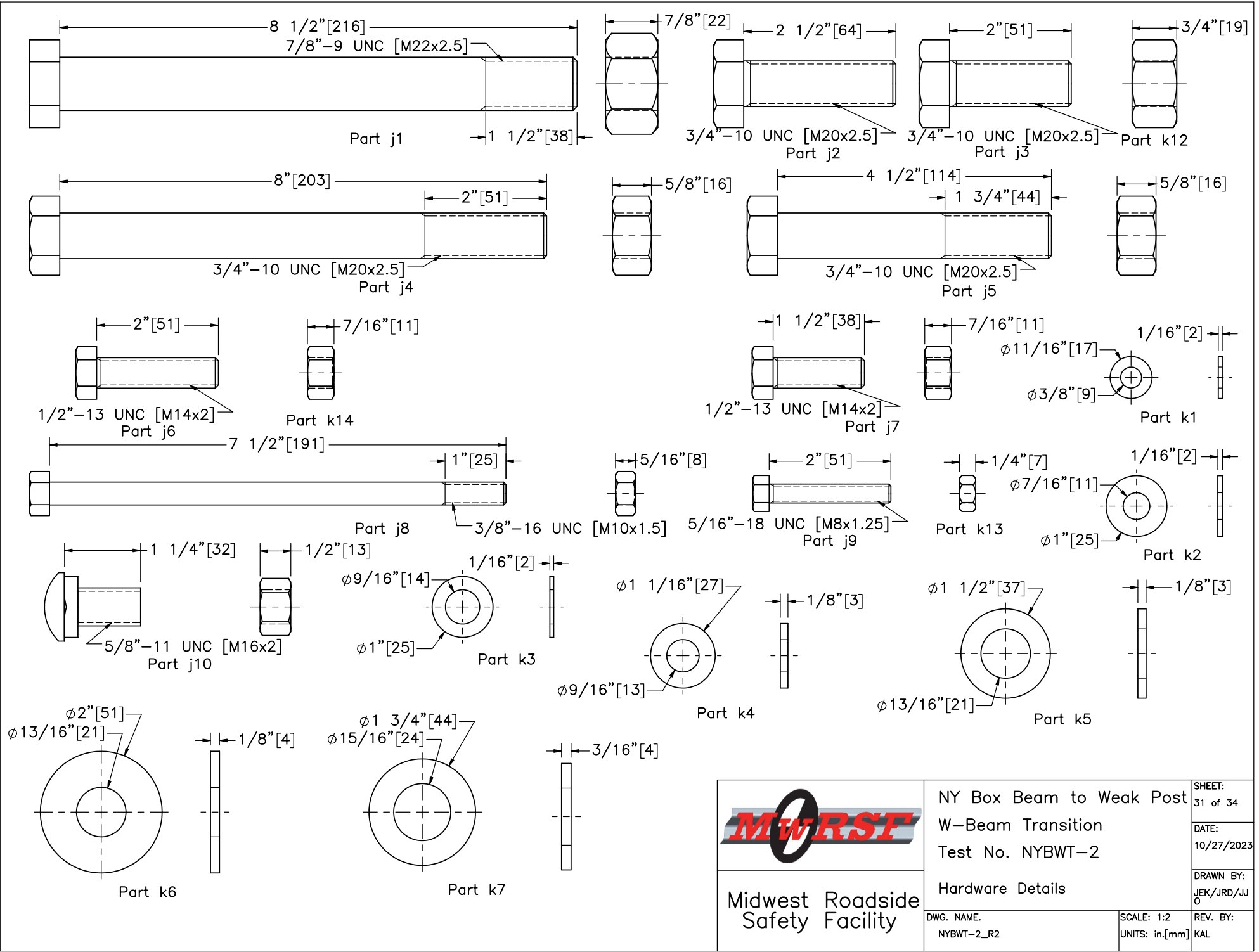

Midwest Roadside Safety Facility

NY Box Beam to Weak Post
W-Beam Transition
Test No. NYBWT-2

Hardware Details

DWG. NAME:
NYBWT-2_R2

SCALE: 1:2
UNITS: in.[mm]

SHEET:
31 of 34

DATE:
10/27/2023

DRAWN BY:
JEK/JRD/JJ
O

REV. BY:
KAL

Item No.	QTY.	Description	Material Specification	Treatment Specification	Hardware Guide
a1	8	12'-6" [3,810] 12-gauge [2.7] W-Beam Section	AASHTO M180	ASTM A123 or A653	RWM02a
a2	2	12'-6" [3,810] 12-gauge [2.7] W-Beam Section	AASHTO M180	ASTM A123 or A653	-
a3	1	12'-6" [3,810] 12-gauge [2.7] W-Beam Curved Section	AASHTO M180	ASTM A123 or A653	RWM11a
a4	6	12" [305] 12-gauge [2.7] W-Beam Backup Plate	AASHTO M180	ASTM A123 or A653	RWB01a
a5	1	W-Beam to Box Beam Transition Cover, 12-gauge [2.7]	ASTM A36	ASTM A123 or A653	-
b1	1	TS6"x6"x3/16" [152x152x5], 215 1/2" [5,474] Long Box Beam	ASTM A500 Gr. B	ASTM A123	-
b2	4	TS6"x6"x3/16" [152x152x5], 215 1/2" [5,474] Long Box Beam	ASTM A500 Gr. B	ASTM A123	-
b3	1	TS6"x6"x3/16" [152x152x5], 215 1/2" [5,474] Long Box Beam	ASTM A500 Gr. B	ASTM A123	-
b4	10	27"x5 7/16"x5/8" [686x138x16] Splice Plate	ASTM A36	-	-
c1	33	S3x5.7 [S75x8.5], 65" [1,651] Long Post	ASTM A36	-	-
c2	33	24"x8"x1/4" [610x203x6] Soil Plate	ASTM A36	-	-
c3	18	5"x3 1/2"x3/8" [127x89x10], 4 1/2" [114] Long L-Bracket	ASTM A36	ASTM A123	-
c4	2	4"x3"x1/4" [102x76x6], 8" [203] Long L-Bracket	ASTM A36	ASTM A123	-
d1	2	W6x15 [W152x22.3], 72" [1,829] Long Post	ASTM A992 or ASTM A572 Gr. 50	-	-
d2	2	20"x14"x3/16" [508x356x5] Plate	ASTM A36	-	-
d3	2	6 3/16"x4"x1/2" [157x102x13] Plate	ASTM A36	-	-
d4	4	6 1/4"x4"x1/2" [159x102x13] Plate	ASTM A36	-	-
d5	2	6 3/16"x6"x1/2" [157x152x13] Plate	ASTM A36	-	-
e1	2	10"x9"x1/2" [254x229x13] Box Beam Cable Anchor Base Plate	ASTM A36	-	-
e2	4	4"x4"x1/4" [102x102x6] Box Beam Cable Anchor Gusset	ASTM A36	-	-
e3	2	4"x4"x1/2" [102x102x13] Box Beam Cable Anchor Mounting Plate	ASTM A36	-	-
f1	2	Concrete	Pre-Cast Class A* Min. f'c = 3,000 psi [20.7 MPa] NE Mix 47BD	-	-
f2	2	#3 [10] Bar, 106 5/8" [2,708] Long Unbent	ASTM A615 Gr. 60 or A996 Gr. 60	Epoxy-Coated (ASTM A775 or A934) **	-
f3	2	#3 [10] Bar, 117 5/8" [2,988] Long Unbent	ASTM A615 Gr. 60 or A996 Gr. 60	Epoxy-Coated (ASTM A775 or A934) **	-
f4	2	#3 [10] Bar, 127 1/8" [3,229] Long Unbent	ASTM A615 Gr. 60 or A996 Gr. 60	Epoxy-Coated (ASTM A775 or A934) **	-

* If cast in place, follow Section 501 - Portland Cement Concrete - General of the NY state standards.

** Epoxy-coating not necessary for testing purposes.



Midwest Roadside
Safety Facility

NY Box Beam to Weak Post
W-Beam Transition
Test No. NYBWT-2

Bill of Materials

DWG. NAME.
NYBWT-2_R2

SCALE: None
UNITS: in.[mm]

SHEET:
32 of 34

DATE:
10/27/2023

DRAWN BY:
JEK/JRD/JJ
O

REV. BY:
KAL

Item No.	QTY.	Description	Material Specification	Treatment Specification	Hardware Guide
f5	8	#3 [10] Bar, 39" [991] Long	ASTM A615 Gr. 60 or A996 Gr. 60	Epoxy-Coated (ASTM A775 or A934) **	-
f6	16	3/4" [19] Dia. UNC, Hooked Anchor J-Bolt and Nut	J-Bolt - ASTM A307 Gr. C Nut - ASTM A563DH	ASTM A153 or B695 Class 55 or F2329	FRH20a
g1	1	14"x9"x1/2" [356x229x13] Cable Anchor Base Plate	ASTM A36	-	-
g2	4	3"x2"x1/4" [76x51x6] Cable Anchor Gusset	ASTM A36	-	-
g3	1	14"x3 1/2"x1/2" [356x89x13] Cable Anchor Top Plate	ASTM A36	-	-
g4	1	1/4" [6] Dia., 16 3/8" [416] Long Brass Rod	ASTM B16-00	-	-
h1	9	3/4" [19] Dia. UNC, 11" [279] Long Threaded Rod	ASTM A307 Gr. A or equivalent	ASTM A153 or B695 Class 55 or F2329	RCE03
h2	12	Cable End Fitting	ASTM A27 Gr. 70-40 Class 1	ASTM A153 or B695	RCE03
h3	12	Cable Wedge	ASTM A47 Gr. 32510	-	FMM01
h4	3	Crosby Threaded Turnbuckle	Stock No. 1034115	As Supplied	-
h5	4	BCT Anchor Cable End Swaged Fitting	Fitting - ASTM A576 Gr. 1035 Stud - ASTM F568 Class C	Fitting - ASTM A153 Stud - ASTM A153 or B695	-
h6	6	3/4" [19] Dia. 3x7 IWRC IPS Wire Rope - Various Lengths	ASTM A741 Type 1	Class A Coating	RCM01
h7	2	3/4" [19] Dia. 6x19 IWRC IPS Wire Rope - Various Lengths	ASTM A741 Type 2	Class A Coating	-
h8	3	3/4" [19] Dia. UNC-LH THD, 11" [279] Long Threaded Rod	ASTM A307 Gr. A or equivalent	ASTM A153 or B695 Class 55 or F2329	RCE03
i1	3	7"x4"x1/2" [178x102x13], 3" [76] Long L-Bracket	ASTM A36	ASTM A123	-
i2	20	1 3/4"x1 3/4"x10-gauge [44x44x3.4] Square Washer	ASTM A36	ASTM A123	-
i3	1	27"x3"x1/4" [686x76x6] Washer Plate	ASTM A36	ASTM A123	-
j1*	2	7/8"-9 UNC [M22x2.5], 8 1/2" [216] Long Heavy Hex Head Bolt and Nut	Bolt - ASTM F3125 Gr. A325 Type 1 or equivalent Nut - ASTM A563DH or equivalent	ASTM A153 or B695 Class 55 or F1136 Gr. 3 or F2329 or F2833 Gr. 1	FBX22b
j2*	2	3/4"-10 UNC [M20x2.5], 2 1/2" [64] Long Fully Threaded Heavy Hex Head Bolt	Bolt - ASTM F3125 Gr. A325 Type 1 or equivalent Nut - ASTM A563DH or equivalent	ASTM A153 or B695 Class 55 or F1136 Gr. 3 or F2329 or F2833 Gr. 1	FBX20b
j3	38	3/4"-10 UNC [M20x2.5], 2" [51] Long Fully Threaded Heavy Hex Head Bolt	Bolt - ASTM F3125 Gr. A325 Type 1 or equivalent Nut - ASTM A563DH or equivalent	ASTM A153 or B695 Class 55 or F1136 Gr. 3 or F2329 or F2833 Gr. 1	FBX20b
j4	11	3/4"-10 UNC [M20x2.5], 8" [203] Long Hex Head Bolt and Nut	Bolt - ASTM A307 Gr. A or equivalent Nut - ASTM A563A or equivalent	ASTM A153 or B695 Class 55 or F2329	FBX20a
j5	2	3/4"-10 UNC [M20x2.5], 4 1/2" [114] Long Hex Head Bolt and Nut	Bolt - ASTM A307 Gr. A or equivalent Nut - ASTM A563A or equivalent	ASTM A153 or B695 Class 55 or F2329	FBX20a
j6	2	1/2"-13 UNC [M14x2], 2" [51] Fully Threaded Long Hex Head Bolt	ASTM A307 Gr. A or equivalent	ASTM A153 or B695 Class 55 or F2329	FBX14a

* If using the alternate splice plates with tapped holes, these hex bolts can be 1/2" [13] shorter.



Midwest Roadside Safety Facility

NY Box Beam to Weak Post
W-Beam Transition
Test No. NYBWT-2

Bill of Materials

DWG. NAME:
NYBWT-2_R2

SCALE: None
UNITS: in.[mm]

SHEET:
33 of 34

DATE:
10/27/2023

DRAWN BY:
JEK/JRD/JJ
O

REV. BY:
KAL

Item No.	QTY.	Description	Material Specification	Treatment Specification	Hardware Guide
j7	18	1/2"-13 UNC [M14x2], 1 1/2" [38] Long Fully Threaded Hex Head Bolt and Nut	Bolt - ASTM A307 Gr. A or equivalent Nut - ASTM A563A or equivalent	ASTM A153 or B695 Class 55 or F2329	FBX14a
j8	18	3/8"-16 UNC [M10x1.5], 7 1/2" [191] Long Hex Head Bolt and Nut	Bolt - ASTM A307 Gr. A or equivalent Nut - ASTM A563A or equivalent	ASTM A153 or B695 Class 55 or F2329	FBX10a
j9	8	5/16"-18 UNC [M8x1.25], 2" [51] Long Fully Threaded Hex Head Bolt	Bolt - ASTM A307 Gr. A or equivalent Nut - ASTM A563A or equivalent	ASTM A153 or B695 Class 55 or F2329	FBX08a
j10	76	5/8"-11 UNC [M16x2], 1 1/4" [32] Long Guardrail Bolt and Nut	Bolt - ASTM A307 Gr. A Nut - ASTM A563A	ASTM A153 or B695 Class 55 or F2329	FBB01
k1	8	5/16" [8] Dia. Hardened Flat Washer	ASTM F436	ASTM A153 or B695 Class 55 or F1136 Gr. 3 or F2329	-
k2	36	3/8" [10] Dia. Plain Round Washer	ASTM F844	ASTM A123 or A153 or F2329	FWC10a
k3	18	1/2" [13] Dia. Plain Narrow Round Washer	SAE Low Carbon Gr. 2	ASTM A153 or B695 Class 55 or F1136 Gr. 3 or F2329	-
k4	2	1/2" [13] Dia. Hardened Flat Washer	ASTM F436	ASTM A153 or B695 Class 55 or F1136 Gr. 3 or F2329	FWC14b
k5	74	3/4" [19] Dia. Hardened Flat Washer	ASTM F436	ASTM A153 or B695 Class 55 or F1136 Gr. 3 or F2329	FWC20b
k6	17	3/4" [19] Dia. Plain Round Washer	ASTM F844	ASTM A123 or A153 or F2329	FWC20a
k7	4	7/8" [22] Dia. Hardened Flat Washer	ASTM F436	ASTM A153 or B695 Class 55 or F1136 Gr. 3 or F2329	FWC22b
k8	4	1" [25] Dia. Plain Round Washer	ASTM F844	ASTM A123 or A153 or F2329	FWC24a
k9	4	1" [25] Dia. UNC Heavy Hex Nut	ASTM A563DH or equivalent	ASTM A153 or B695 Class 55 or F2329	FNX24b
k10	12	3/4" [19] Dia. UNC Square Nut	ASTM A563A or equivalent	ASTM A153 or B695 Class 55 or F2329	FNS20
k11	12	3/4" [19] Dia. UNC Hex Nut	ASTM A563A or equivalent	ASTM A153 or B695 Class 55 or F2329	FNX20a
k12*	40	3/4" [19] Dia. UNC Heavy Hex Nut	ASTM A563DH or equivalent	-	FNX20b
k13	16	5/16" [8] Dia. UNC Hex Nut	ASTM A563A or equivalent	ASTM A153 or B695 Class 55 or F2329	FNX08a
k14	4	1/2" [13] Dia. UNC Hex Nut	ASTM A563A or equivalent	ASTM A153 or B695 Class 55 or F2329	FNX14a

* If using the alternate splice plates with tapped holes, these additional hex nuts are not required.

Washer	Washer Series	Inside Diameter			Outside Diameter			Thickness		
		Basic	Tolerance		Basic	Tolerance		Basic	Max.	Min.
			Plus	Minus		Plus	Minus			
3/4"	Regular (k5)	0.812"	0.03"	0.007"	1.469"	0.03"	0.007"	0.134"	0.16"	0.108"
	Wide (k6)	0.812"	0.03"	0.007"	2"	0.03"	0.007"	0.165"	0.192"	0.136"



Midwest Roadside Safety Facility

NY Box Beam to Weak Post
W-Beam Transition
Test No. NYBWT-2

Bill of Materials

DWG. NAME:
NYBWT-2_R2

SCALE: None
UNITS: in.[mm]

SHEET:
34 of 34
DATE:
10/27/2023
DRAWN BY:
JEK/JRD/JJ
O
REV. BY:
KAL

REV.	DATE OF ISSUE	Page	NATURE OF CHANGES	REVIEWER	REVISED BY
0	5/11/2018	-	Created from NYBWT-1_R14.	-	JEK
1	8/23/2019	-	Renamed HFT anchor assembly to upstream anchor post assembly.	KAL	JRD
		1	Edited upstream anchor annotation and note 4.		
		3	Edited upstream anchor post assembly annotation.		
		10	Edited upstream anchor post assembly annotation.		
		20	Renamed sheet and BOM to upstream anchor post assembly.		
		21	Renamed sheet to upstream anchor post components.		
2	10/27/2023	All	Changed to NY Box Beam to Weak Post	KAL	JJO
		2	Corrected a4 backing plate location, updated detail views I & J		
		8	Added splice plate note.		
		25	Updated transition anchor cable to show correct LH threaded part in turnbuckle.		
		26	Added threaded rod detail part no h8.		
		BOM	Updated BOM with part no. h8.		