

Note: (1) Impact location is 51 3/16" [1300] upstream of joint between barrier nos. 8 and 9.

	Wisconsin DOT Low Deflection Portable Concrete Barrier		SHEET: 1 of 16
	System Layout		DATE: 2/11/2014
Midwest Roadside Safety Facility	DWG. NAME: LDPCB_v6_R9	SCALE: 1:270 UNITS: in.[mm]	DRAWN BY: CWP/SDB/ESG
			REV. BY: KAL/JGP/RWB/RKF

Downstream

Upstream

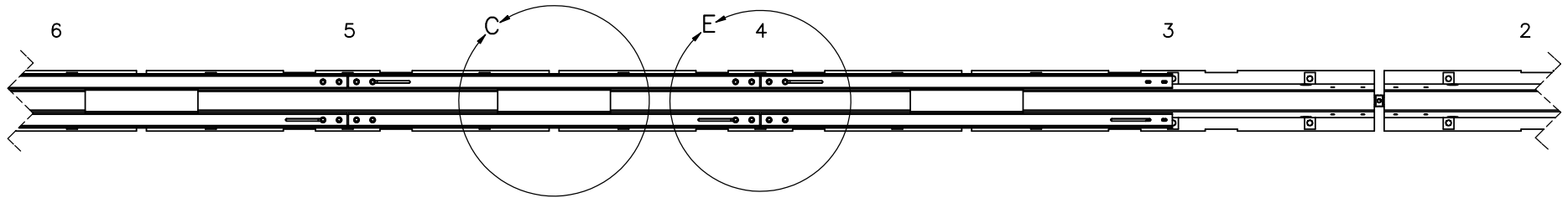

PLAN VIEW

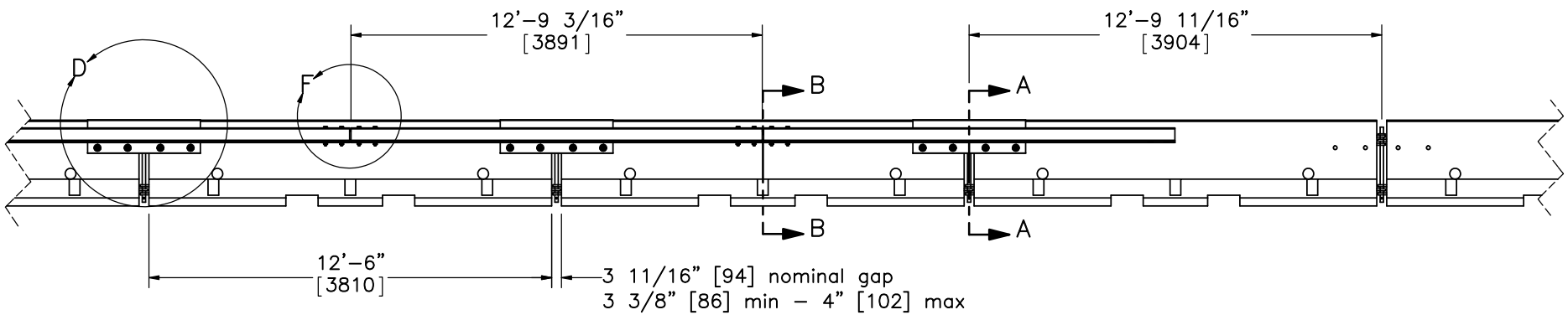

ELEVATION VIEW

Note: (1) Bridge deck omitted.



Midwest Roadside
Safety Facility

Wisconsin DOT Low
Deflection Portable
Concrete Barrier

Concrete Barrier Assembly

DWG. NAME:
LDPCB_v6_R9

SCALE: 1:60
UNITS: in.[mm]

SHEET:
2 of 16
DATE:
2/11/2014
DRAWN BY:
CWP/SDB/
ESG
REV. BY:
KAL/JGP/
RWB/RKF

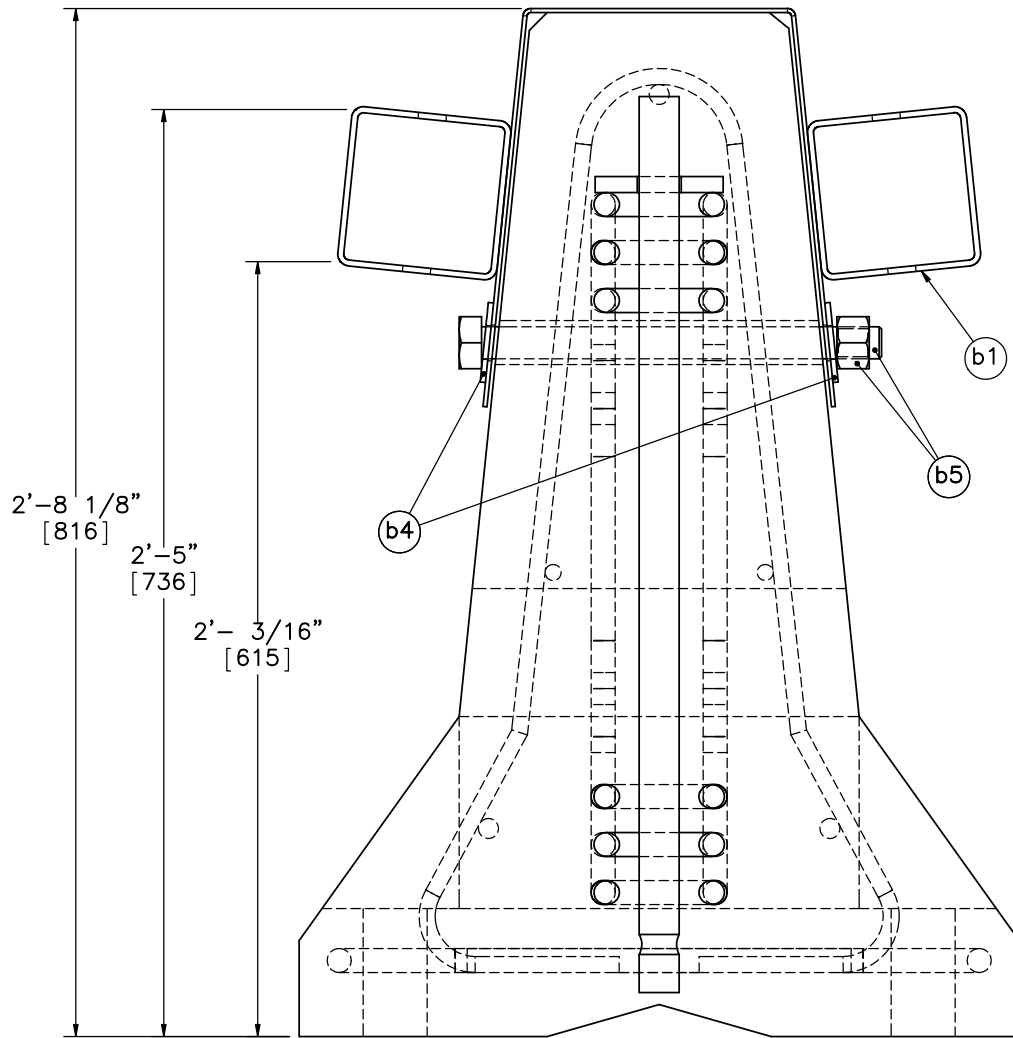

SECTION A-A

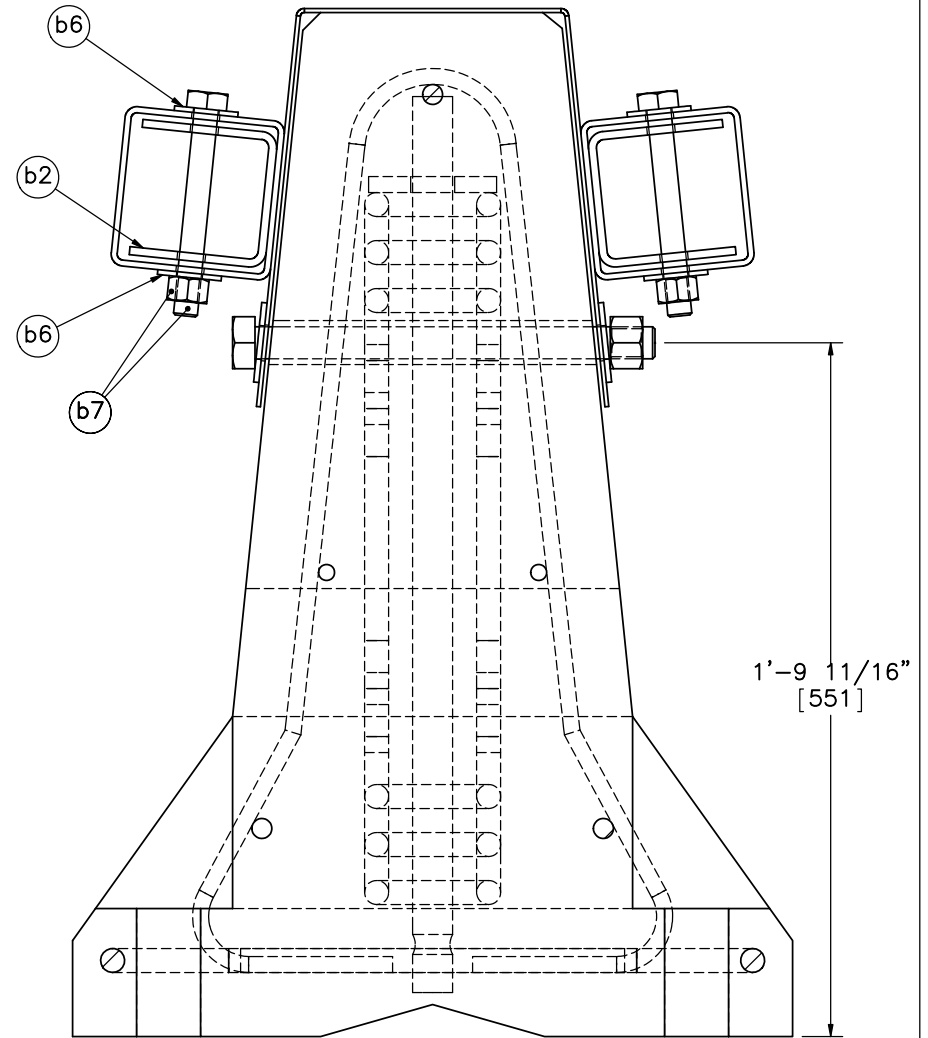

SECTION B-B

- Notes: (1) ASTM A449 or ASTM A193 B7 threaded rod may be used in lieu of bolts (Parts b9 and b5).
 (2) If threaded rod is used in lieu of cup or L-Bracket bolts, limit thread extension beyond nut to 1/4"-1/2" [6-13].



Midwest Roadside
Safety Facility

Wisconsin DOT Low
Deflection Portable
Concrete Barrier

Assembly Section View

DWG. NAME:
LDPCB_v6_R9

SCALE: 1:6
UNITS: in.[mm]

SHEET:
3 of 16

DATE:
2/11/2014

DRAWN BY:
CWP/SDB/
ESG

REV. BY:
KAL/JGP/
RWB/RKF

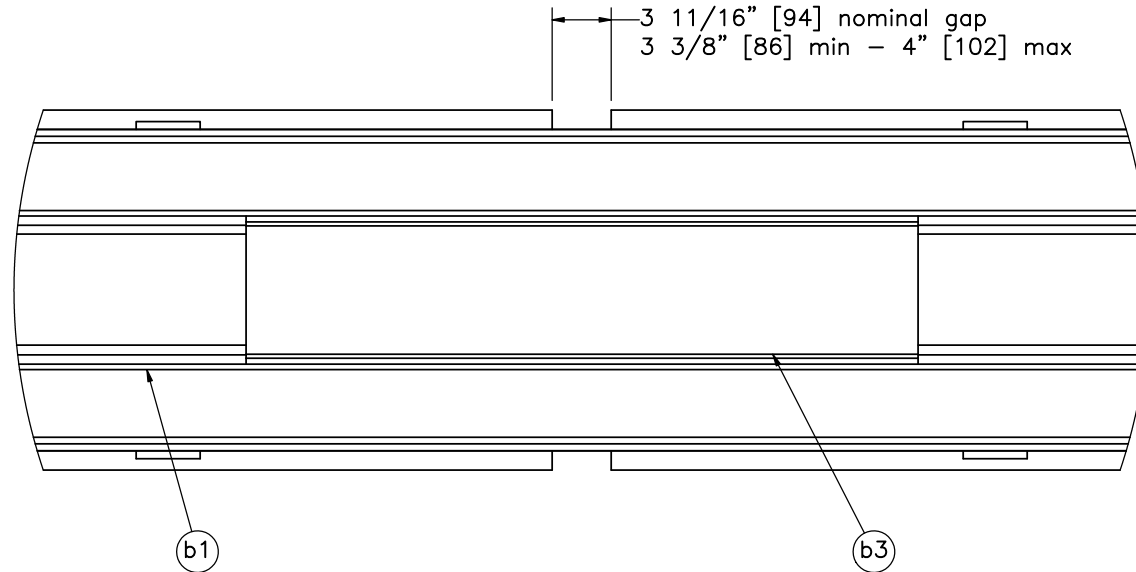

DETAIL C (PLAN VIEW)

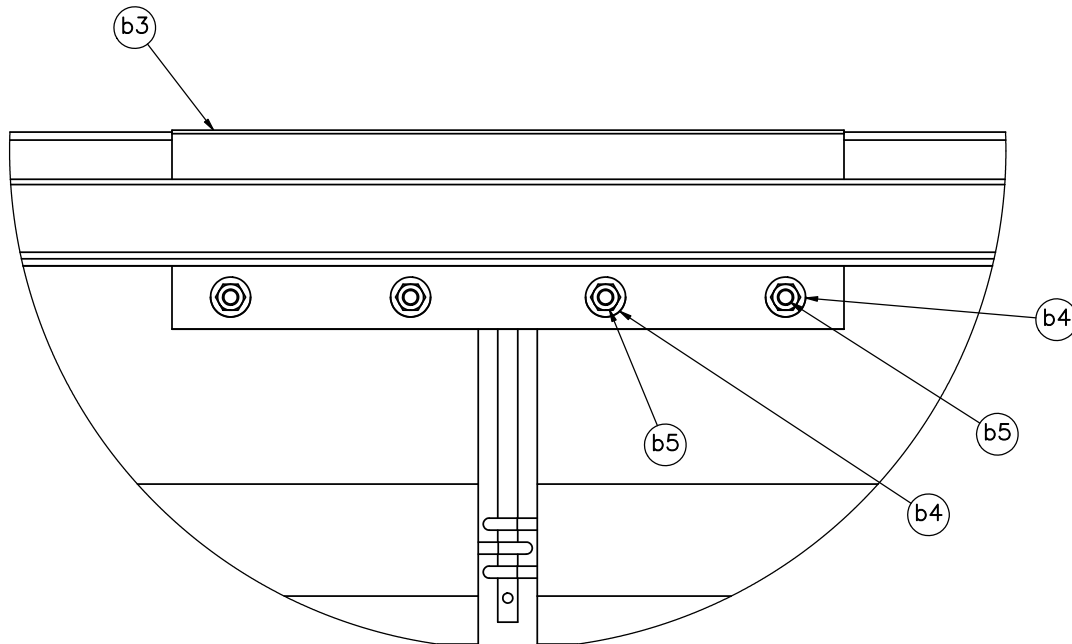

DETAIL D (ELEVATION VIEW)

- Notes: (1) Shown with nominal gap, but variations in gap width will change overlap of cap.
 (2) Cap shall be centered over joint.

	Wisconsin DOT Low Deflection Portable Concrete Barrier		SHEET: 4 of 16
	Mounting Bracket Detail		DATE: 2/11/2014
Midwest Roadside Safety Facility		DWG. NAME: LDPCB_v6_R9	DRAWN BY: CWP/SDB/ESG
		SCALE: 1:12 UNITS: in.[mm]	REV. BY: KAL/JGP/RWB/RKF

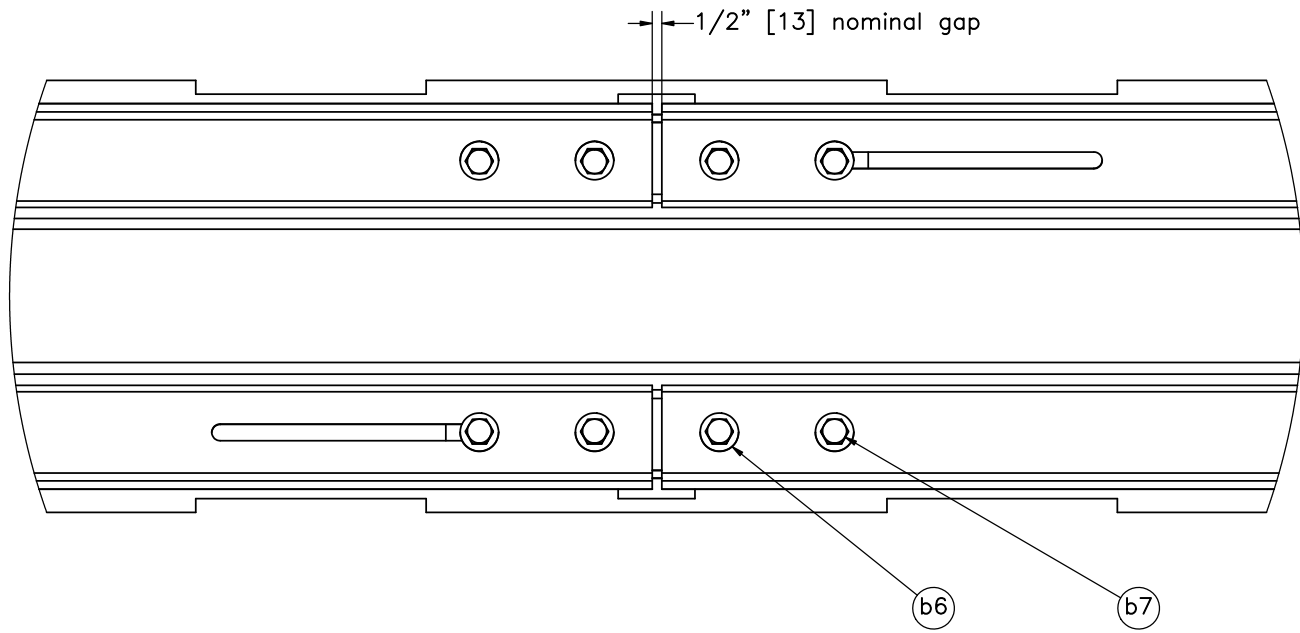

DETAIL E (PLAN VIEW)

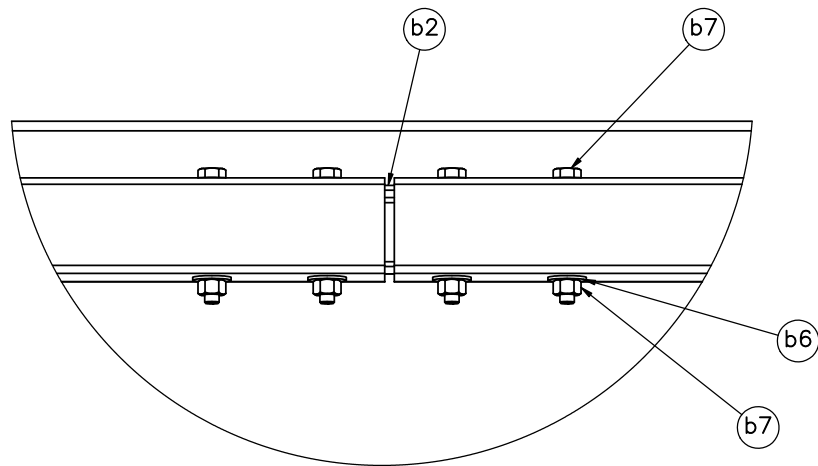

DETAIL F (ELEVATION VIEW)



Midwest Roadside
Safety Facility

Wisconsin DOT Low
Deflection Portable
Concrete Barrier

Splice Connection Detail

DWG. NAME:
LDPCB_v6_R9

SCALE: 1:10
UNITS: in.[mm]

SHEET:
5 of 16

DATE:
2/11/2014

DRAWN BY:
CWP/SDB/
ESG

REV. BY:
KAL/JGP/
RWB/RKF

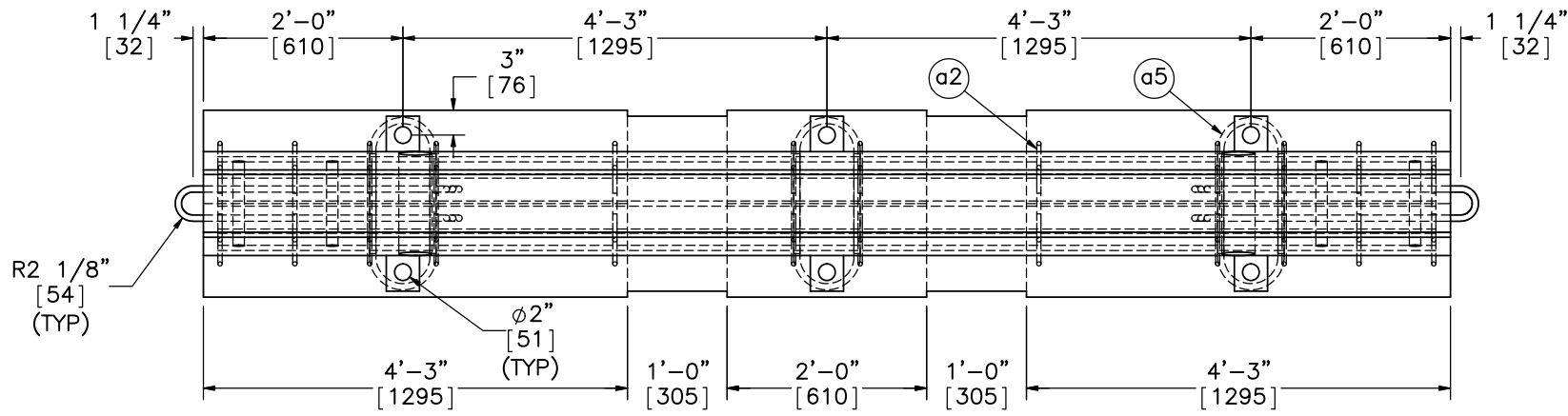

PLAN VIEW

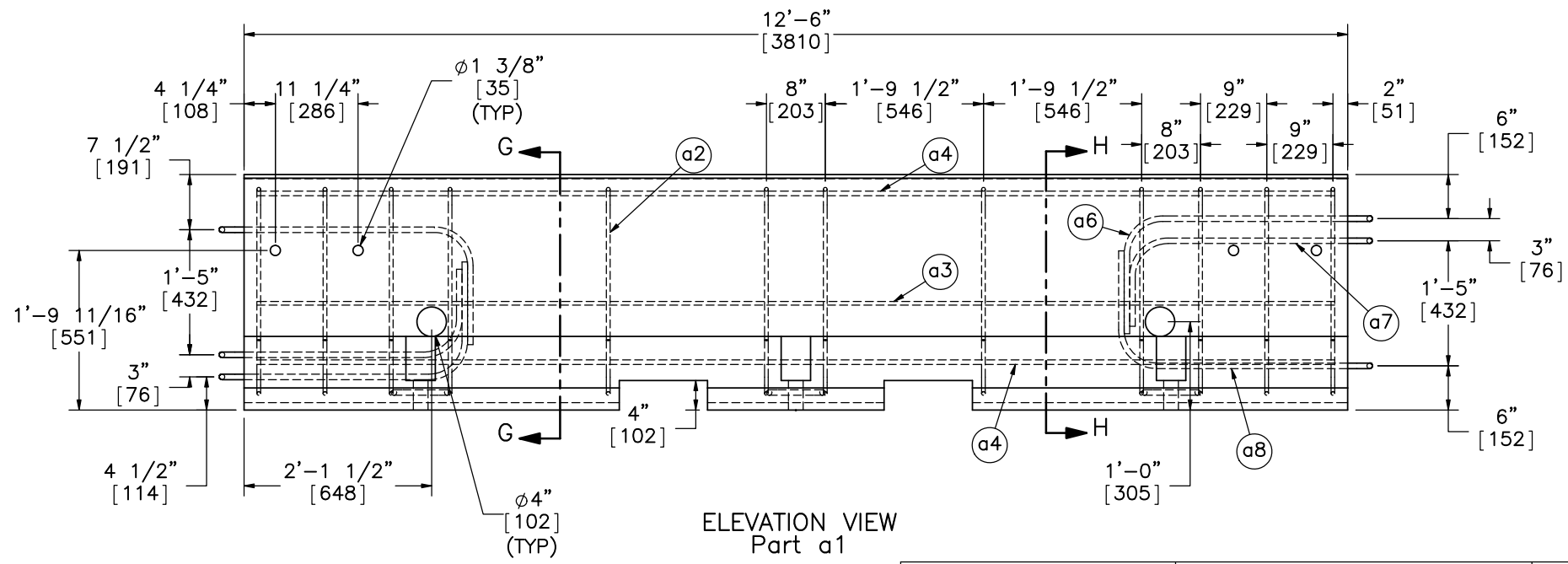

ELEVATION VIEW
Part a1

Note: (1) Holes for barrier joint are prefabricated using 1 1/4" [32] schedule 40 PVC with inner diameter of 1.36" [35].

 Midwest Roadside Safety Facility	Wisconsin DOT Low Deflection Portable Concrete Barrier	SHEET: 6 of 16
	Portable Concrete Barrier Details	DATE: 2/11/2014
DWG. NAME: LDPCB_v6_R9	SCALE: 1:22 UNITS: in.[mm]	DRAWN BY: CWP/SDB/ ESG REV. BY: KAL/JGP/ RWB/RKF

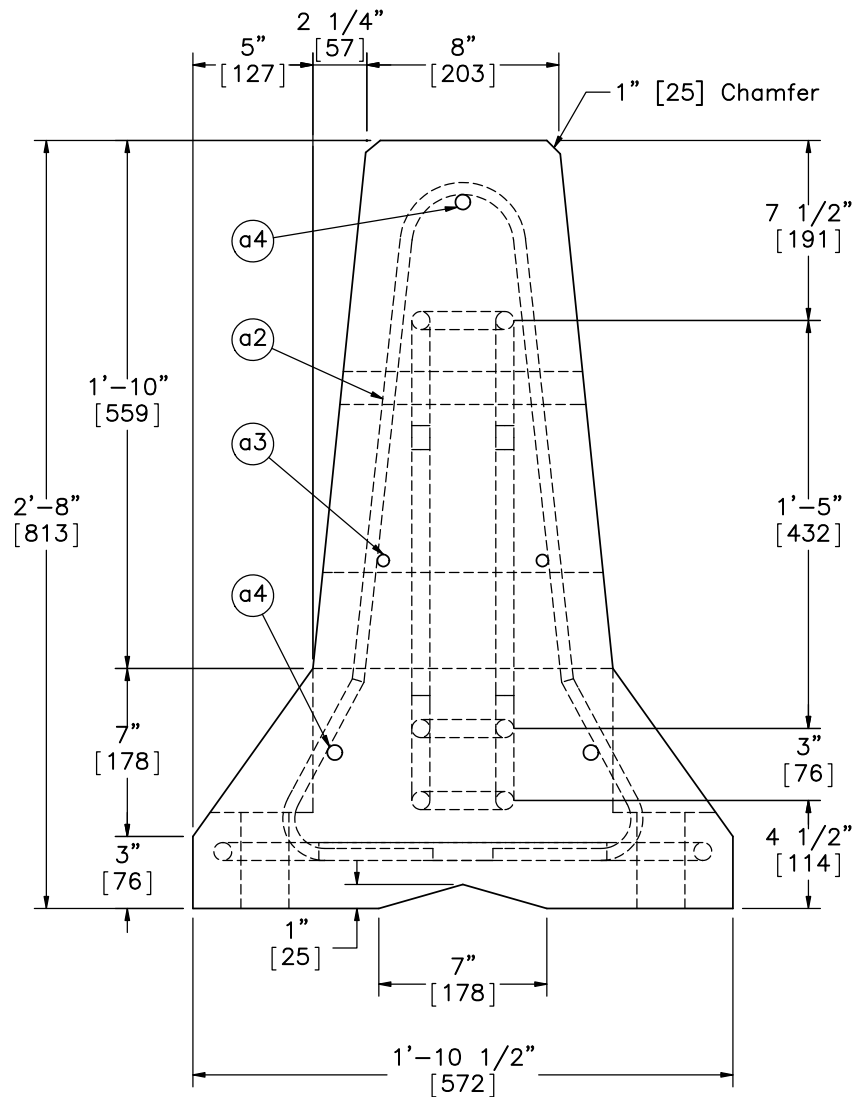

SECTION G-G

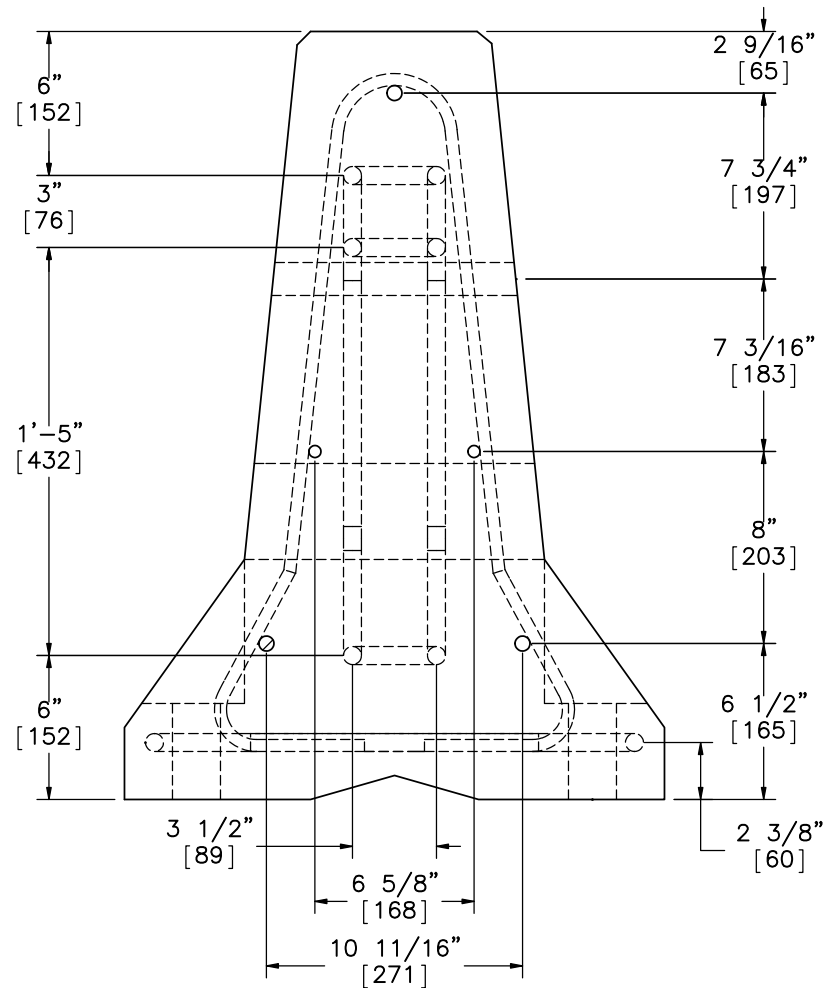

SECTION H-H

Note: (1) 2" [51] clear cover used for all reinforcement.



Midwest Roadside
Safety Facility

Wisconsin DOT Low
Deflection Portable
Concrete Barrier

Portable Concrete Barrier
Details

DWG. NAME:
LDPCB_v6_R9

SCALE: 1:8
UNITS: in.[mm]

SHEET:
7 of 16

DATE:
2/11/2014

DRAWN BY:
CWP/SDB/
ESG

REV. BY:
KAL/JGP/
RWB/RKF

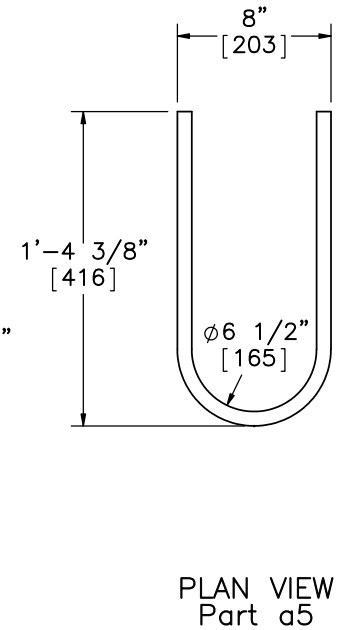
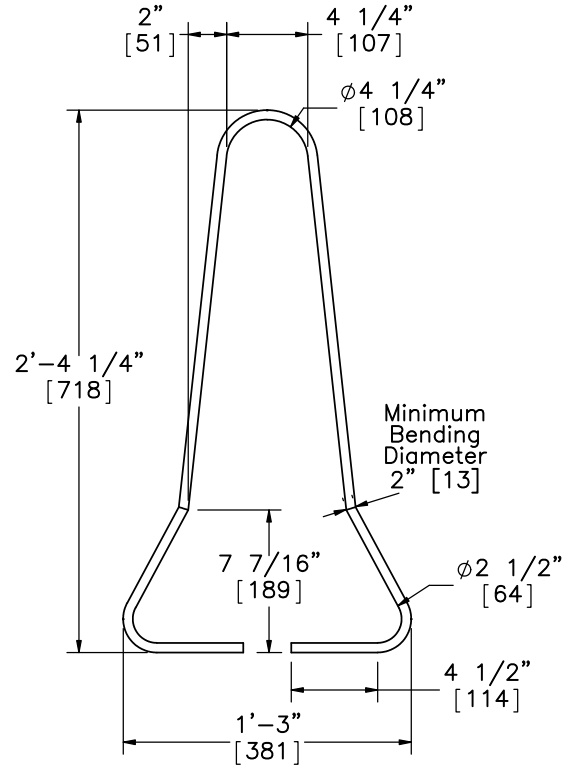
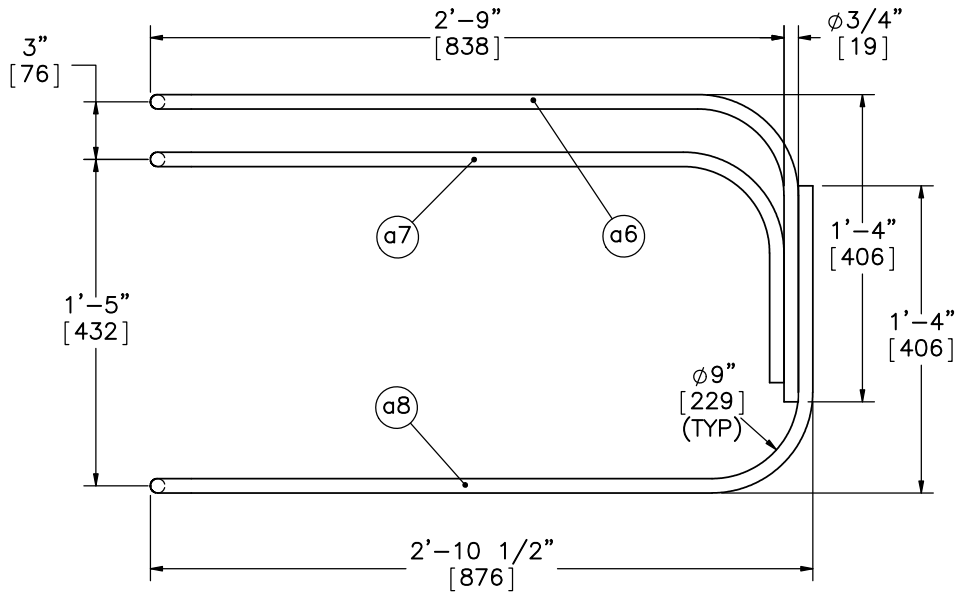
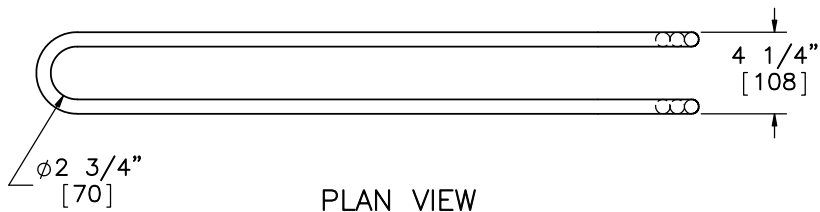

Midwest Roadside
Safety Facility

Wisconsin DOT Low
Deflection Portable
Concrete Barrier

Portable Concrete Barrier Rebar
Details

DWG. NAME:
LDPCB_v6_R9

SCALE: 1:10
UNITS: in.[mm]

SHEET:
8 of 16

DATE:
2/11/2014

DRAWN BY:
CWP/SDB/
ESG

REV. BY:
KAL/JGP/
RWB/RKF

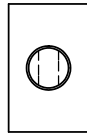

PLAN VIEW

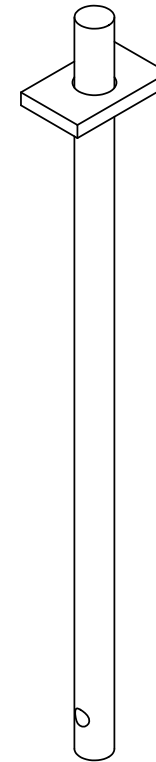

ISOMETRIC VIEW

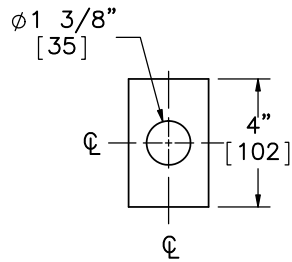

PLAN VIEW

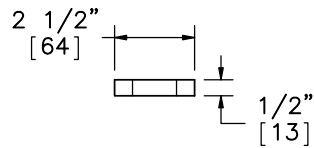

ELEVATION VIEW
PLATE

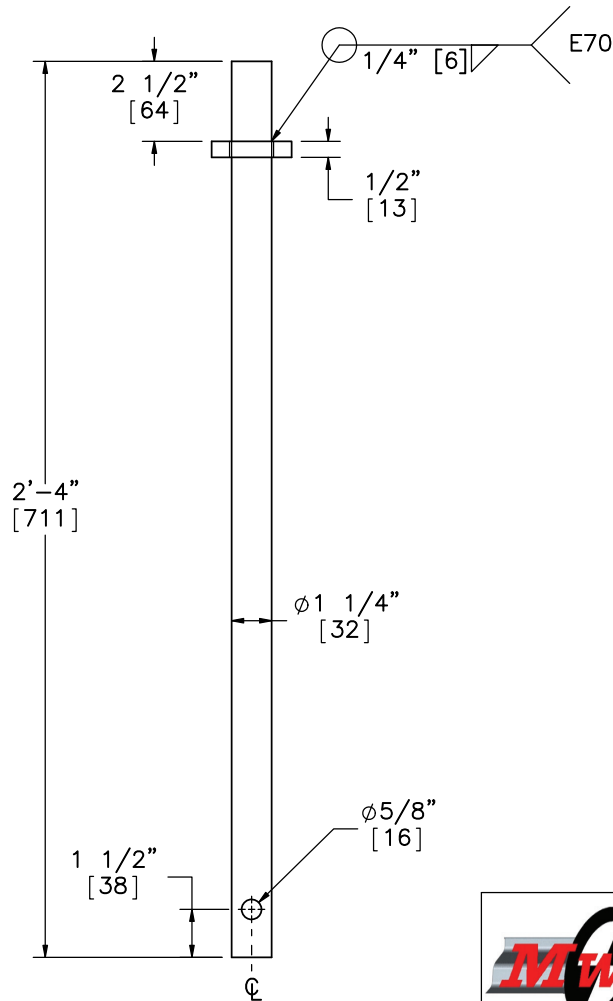

ELEVATION VIEW
Part a9



Midwest Roadside
Safety Facility

Wisconsin DOT Low
Deflection Portable
Concrete Barrier

Connector Pin Details

DWG. NAME:
LDPCB_v6_R9

SCALE: 1:6
UNITS: in.[mm]

SHEET:
9 of 16

DATE:
2/11/2014

DRAWN BY:
CWP/SDB/
ESG

REV. BY:
KAL/JGP/
RWB/RKF

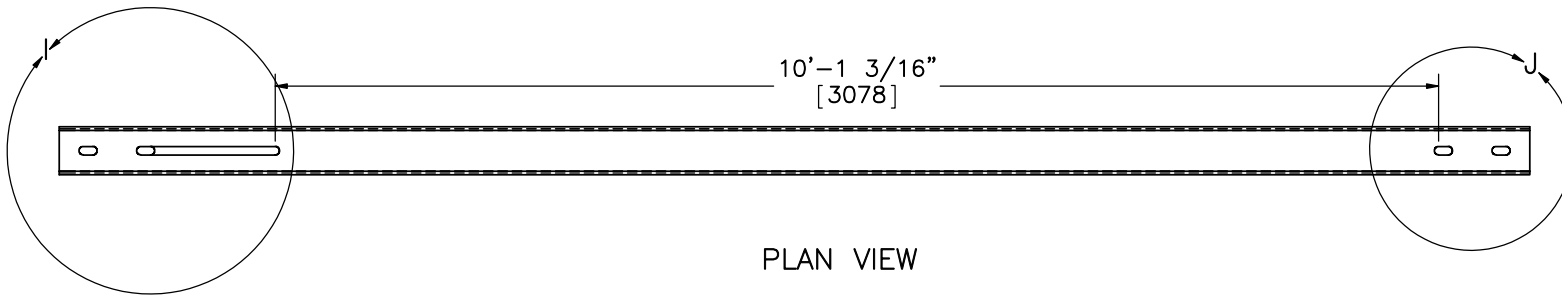

PLAN VIEW

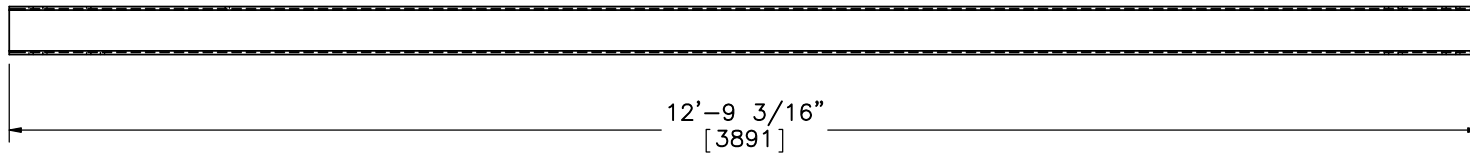

ELEVATION VIEW

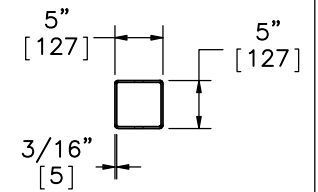

PROFILE VIEW

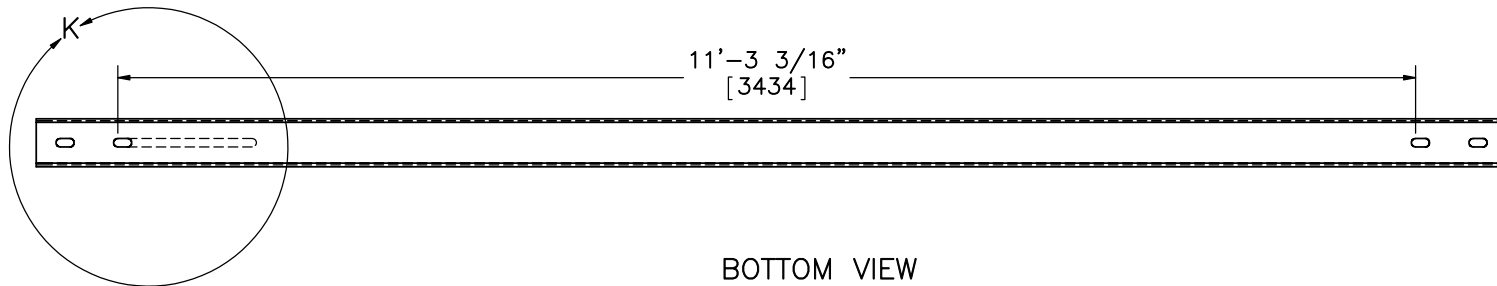

BOTTOM VIEW

Part b1



Midwest Roadside
Safety Facility

Wisconsin DOT Low
Deflection Portable
Concrete Barrier

Splice Main Tube

DWG. NAME:
LDPCB_v6_R9

SCALE: 1:20
UNITS: in.[mm]

SHEET:
10 of 16

DATE:
2/11/2014

DRAWN BY:
CWP/SDB/
ESG

REV. BY:
KAL/JGP/
RWB/RKF

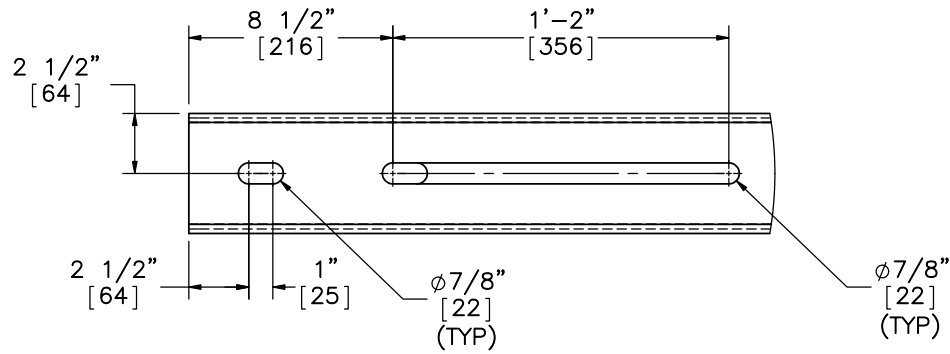

DETAIL I (PLAN VIEW)

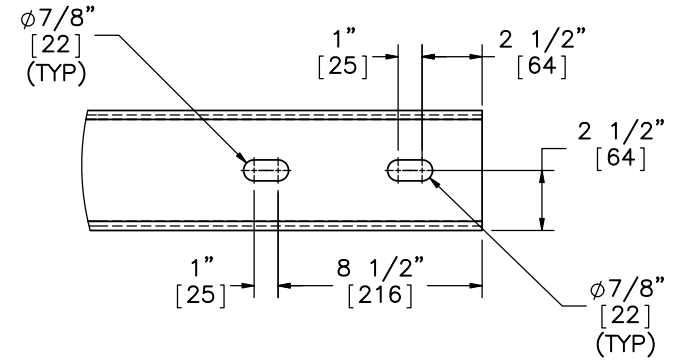

DETAIL J (PLAN VIEW)

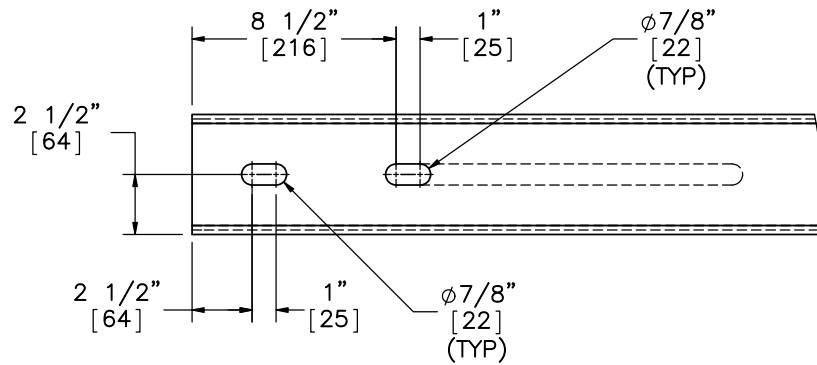

DETAIL K (BOTTOM VIEW)



Midwest Roadside
Safety Facility

Wisconsin DOT Low
Deflection Portable
Concrete Barrier

Splice Slot Detail

DWG. NAME:
LDPCB_v6_R9

SCALE: 1:8
UNITS: in.[mm]

SHEET:
11 of 16

DATE:
2/11/2014

DRAWN BY:
CWP/SDB/
ESG

REV. BY:
KAL/JGP/
RWB/RKF

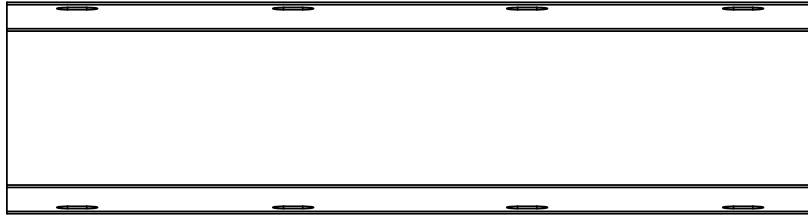

PLAN VIEW

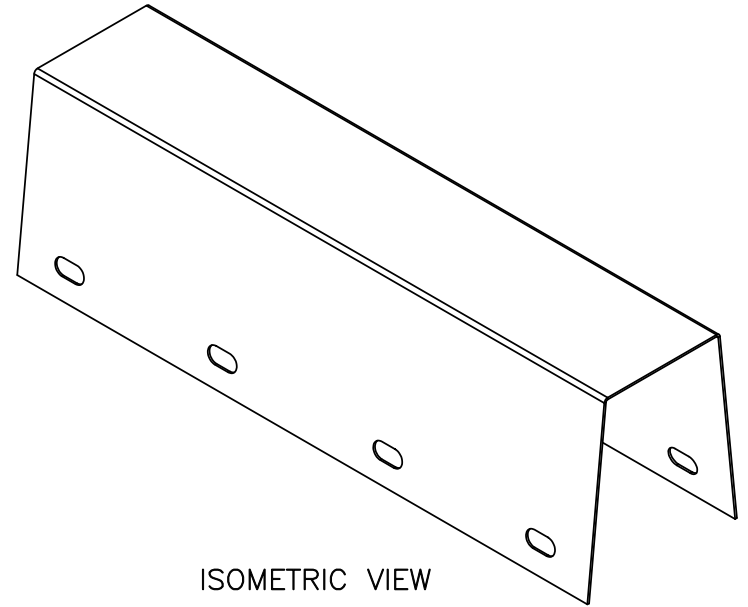

ISOMETRIC VIEW

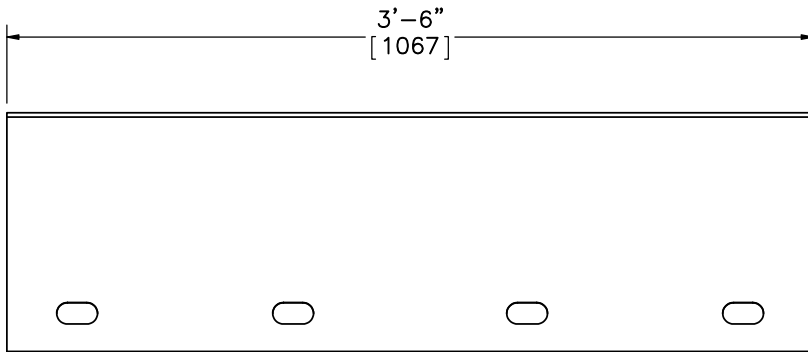

ELEVATION VIEW

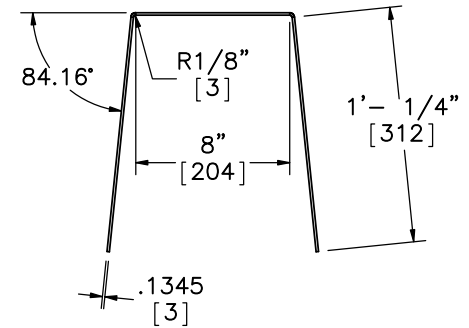

PROFILE VIEW

Part b3



Midwest Roadside
Safety Facility

Wisconsin DOT Low
Deflection Portable
Concrete Barrier

Mounting Bracket (Bent)

DWG. NAME:
LDPCB_v6_R9

SCALE: 1:10
UNITS: in.[mm]

SHEET:
12 of 16

DATE:
2/11/2014

DRAWN BY:
CWP/SDB/
ESG

REV. BY:
KAL/JGP/
RWB/RKF

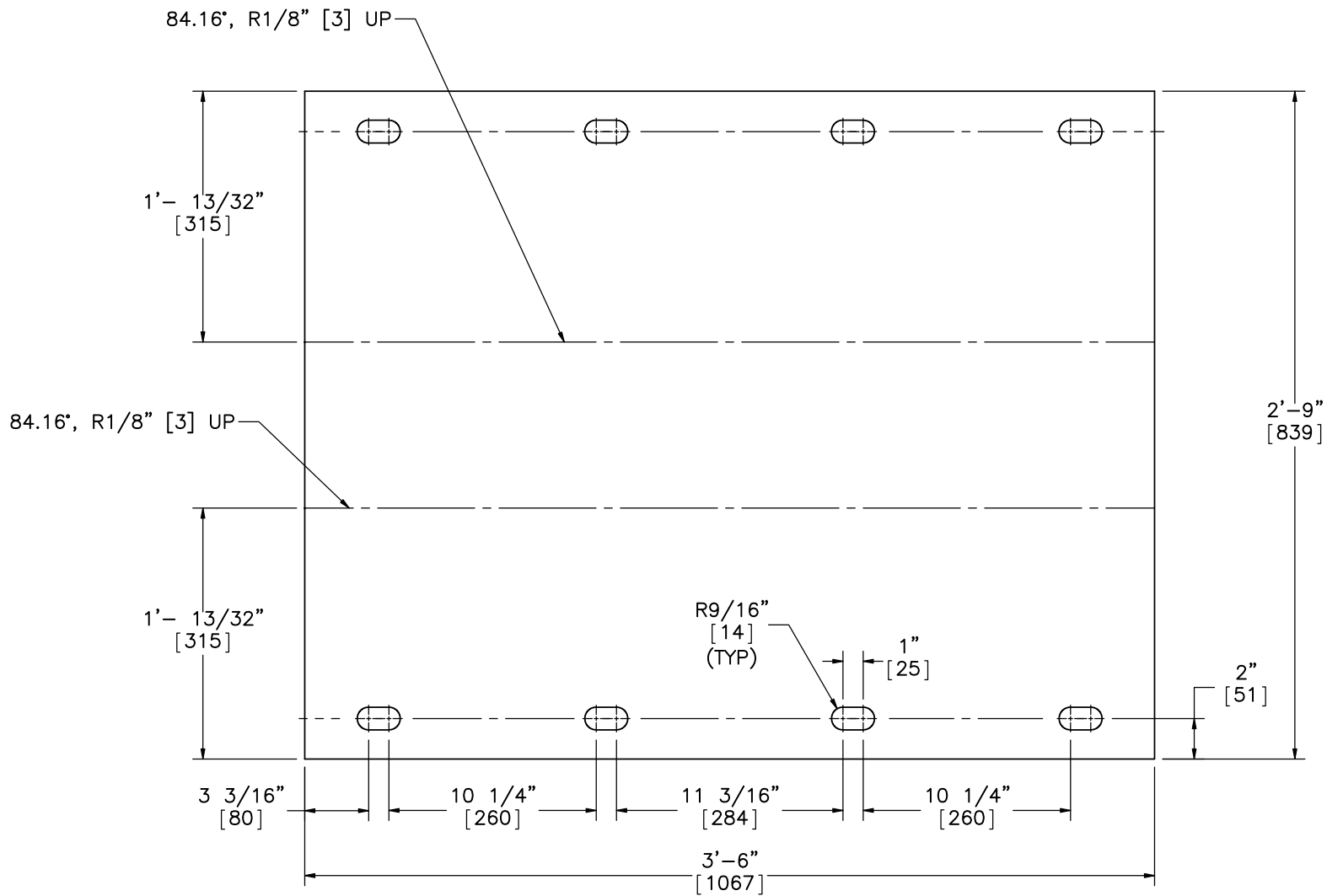

Part b3 (Unbent)

	Wisconsin DOT Low Deflection Portable Concrete Barrier		SHEET: 13 of 16
	Mounting Bracket (Unbent)		DATE: 2/11/2014
Midwest Roadside Safety Facility	DWG. NAME: LDPCB_v6_R9	SCALE: 1:8 UNITS: in.[mm]	DRAWN BY: CWP/SDB/ESG REV. BY: KAL/JGP/RWB/RKF

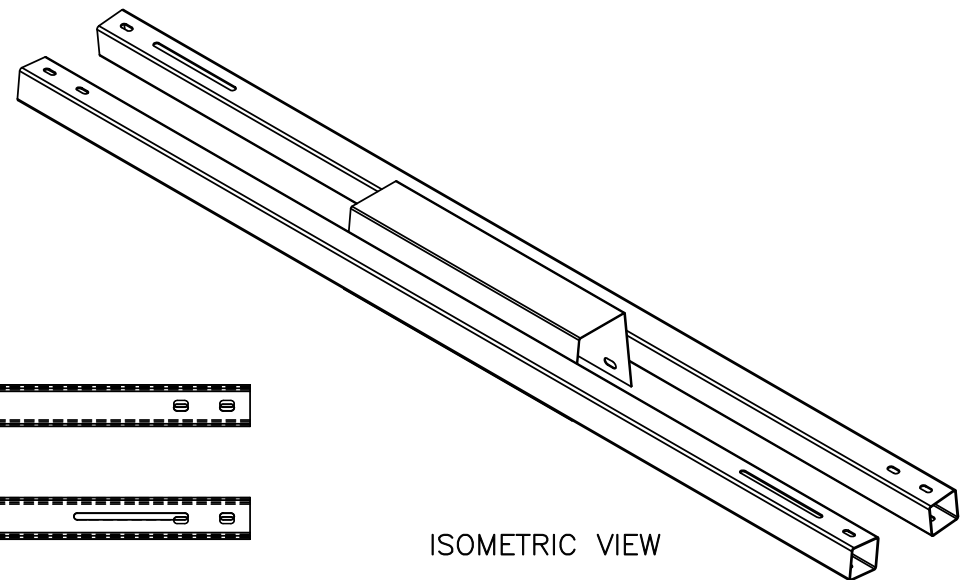

ISOMETRIC VIEW



PLAN VIEW

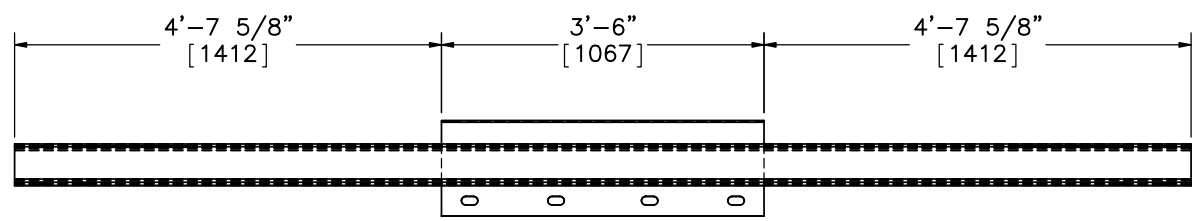

ELEVATION VIEW

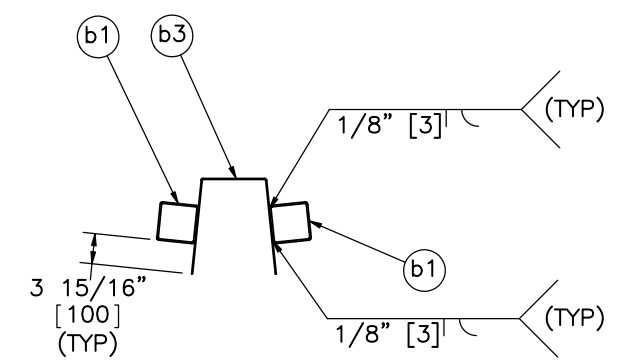

PROFILE VIEW

Note: (1) Parts shall be galvanized after assembly and welding.

 Midwest Roadside Safety Facility	Wisconsin DOT Low Deflection Portable Concrete Barrier		SHEET: 14 of 16
	Mounting Bracket Assembly		DATE: 2/11/2014
DWG. NAME: LDPCB_v6_R9	SCALE: 1:25 UNITS: in.[mm]	REV. BY: KAL/JGP/ RWB/RKF	DRAWN BY: CWP/SDB/ ESG

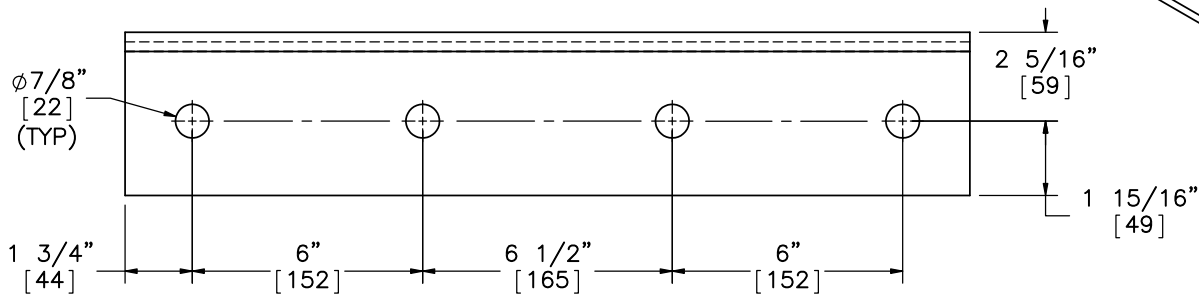

PLAN VIEW

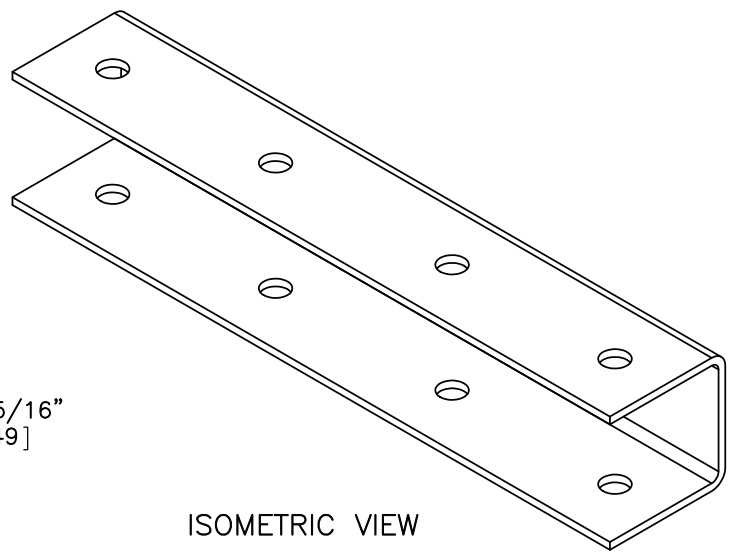

ISOMETRIC VIEW

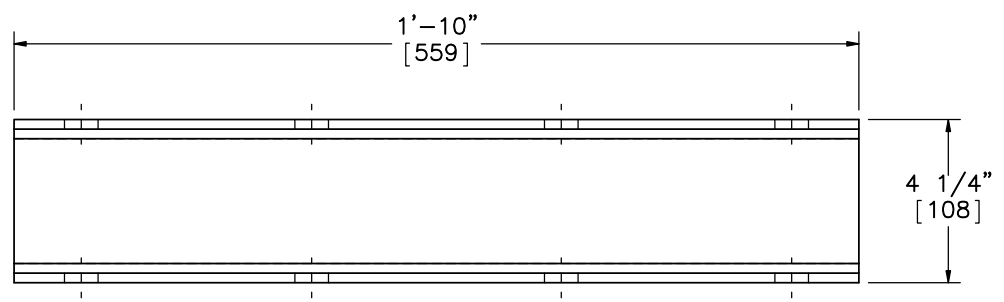

ELEVATION VIEW

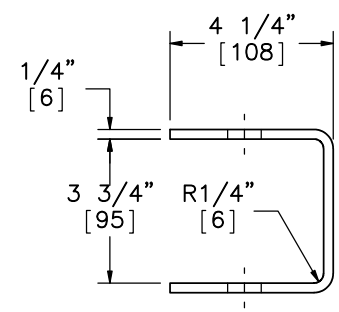

PROFILE VIEW

Part b2

 Midwest Roadside Safety Facility	Wisconsin DOT Low Deflection Portable Concrete Barrier Splice Insert		SHEET: 15 of 16
	DWG. NAME: LDPCB_v6_R9	SCALE: 1:5 UNITS: in.[mm]	REV. BY: KAL/JGP/RWB/RKF

Item No.	QTY.	Description	Material Specifications	Hardware
a1	16	Portable Concrete Barrier	min f'c=5000 psi [34.5 MPa]	SWC09
a2	192	1/2" [13] Dia., 72" [1829] Long Form Bar	ASTM A615 Grade 60	SWC09
a3	32	1/2" [13] Dia., 146" [3708] Long Longitudinal Bar	ASTM A615 Grade 60	SWC09
a4	48	5/8" [16] Dia., 146" [3708] Long Longitudinal Bar	ASTM A615 Grade 60	SWC09
a5	96	3/4" [19] Dia., 36" [914] Long Anchor Loop Bar	ASTM A615 Grade 60	SWC09
a6	32	3/4" [19] Dia., 101" [2565] Long Connection Loop Bar	ASTM A709 Grade 70 or A706 Grade 60	SWC09
a7	32	3/4" [19] Dia., 91" [2311] Long Connection Loop Bar	ASTM A709 Grade 70 or A706 Grade 60	SWC09
a8	32	3/4" [19] Dia., 102" [2591] Long Connection Loop Bar	ASTM A709 Grade 70 or A706 Grade 60	SWC09
a9	15	1 1/4" [32] Dia., 28" [711] Long Connector Pin	ASTM A36 Galvanized	FMW02
b1	22	5"x5"x3/16" [127x127x5], 12'-9 3/16" [3891] Long Splice Main Tube	ASTM A500 Grade B Galvanized after Welding	-
b2	20	4 1/2"x4 1/2"x1/4" [114x114x6], 22" [559] Long Splice Insert	ASTM 572 Grade 50 Galvanized	-
b3	11	42"x33" [1067x838] 10 Gage Mounting Bracket Plate	ASTM A1011 Grade 50 Galvanized after Welding	-
b4	88	1" [25] Dia. Washer	ASTM F844 Galvanized	-
b5	44	1" [25] Dia. UNC, 12 1/2" [318] Long Heavy Hex Bolt and Nut	Bolt ASTM A325/A449 Type 1 Galvanized, Nut ASTM A563DH Galvanized	-
b6	160	3/4" [19] Dia. Washer	ASTM F844 Galvanized	-
b7	80	3/4" [19] Dia. UNC, 6 1/2" [165] Long, 2" [51] Threaded Hex Bolt and Nut	Bolt ASTM A325/A449/SAE Grade 5 Galvanized, Nut ASTM A563DH Grade 5 Galvanized	-



Midwest Roadside
Safety Facility

Wisconsin DOT Low
Deflection Portable
Concrete Barrier

Bill of Materials

DWG. NAME.
LDPCB_v6_R9

SCALE: NONE
UNITS: in.[mm]

SHEET:
16 of 16

DATE:
2/11/2014

DRAWN BY:
CWP/SDB/
ESG

REV. BY:
KAL/JGP/
RWB/RKF