

PLAN

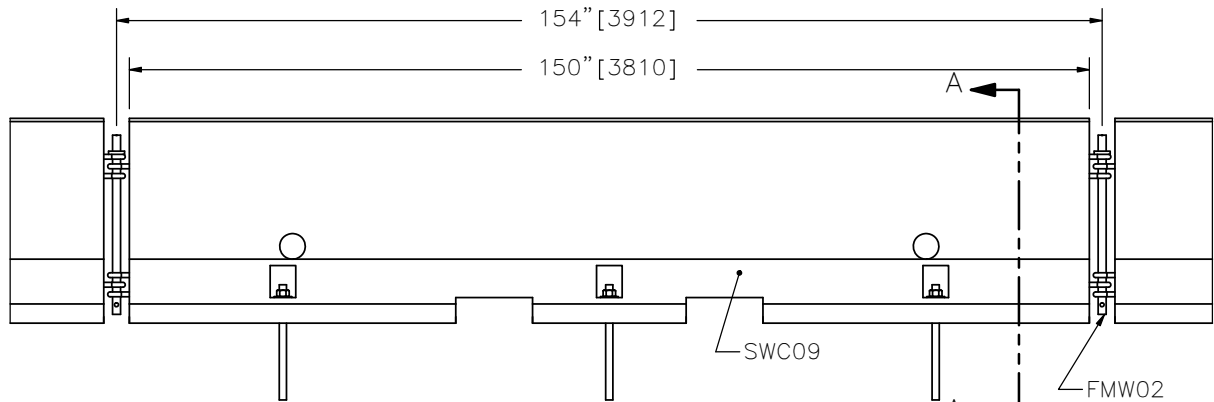

ELEVATION

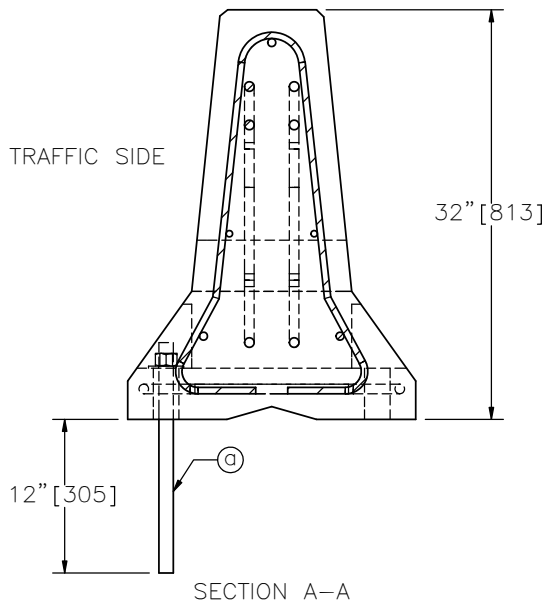

TRAFFIC SIDE

SECTION A-A

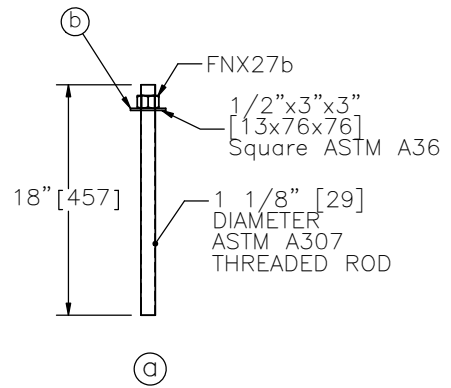

NOTE: THROUGH BOLTING IS ALSO AN ACCEPTABLE ANCHORING OPTION.

BOLTED-DOWN PORTABLE F-SHAPE CONCRETE BARRIER



SWC11

SHEET NO.

DATE:

1 of 4

10/22/2008

INTENDED USE

Bolted-Down Portable F-Shape Concrete Barrier is a non-proprietary system and is to be used as a work-zone barrier to protect traffic and workers. Bolted-Down Portable F-Shape Concrete Barrier should be used in locations where a maximum dynamic deflection of 11 1/4" [287] or less is acceptable and where a working width of 21"[534] is provided. The system should be placed with a minimum distance of 1" [25] between the back face of the concrete barrier and the edge of the bridge deck. Bolted-Down Portable F-Shape Concrete Barrier was designed for use on a concrete bridge deck with a minimum compressive strength of 4,000 psi [28 MPa] and should not be used on a bridge deck with an asphalt overlay. The Bolted-Down System is intended for use with the Portable F-shape Concrete Barrier Element (SWC09) and the Portable Concrete Barrier Connector Pins with or without the retainer bolt (FMW02 or FMW03). The Bolted-Down Portable F-Shape Concrete Barrier is TL-3 NCHRP 350 accepted.

SPECIFICATIONS

Epoxy

The epoxy must meet the ASTM D695 standard for Compressive Strength, up to 14,740 psi [101.6 MPa] for a 7-day cure, the ASTM D638 standard for Tensile Strength, up to 7,400 [51 MPa] for Standard Set curing, and the Bond Strength with a dry cure should be at least 3,000 psi [20.7 MPa] for a steel to concrete bond.

Galvanization

The threaded rod should be zinc-coated according to AASHTO M111 (ASTM A123) except when corrosion resistant steel is requested.

COMPONENTS

Unit Length = 154" [3912]

DESIGNATOR	COMPONENT	SYSTEM	NUMBER
FNX27b	Heavy Hex nut		3
-----	Square washer		3
FMW02	Portable Concrete Barrier Connector Pin		1
FMW03	Portable Concrete Barrier Connector Pin with Retaining Bolt		1
SWC09	F-Shape Portable Concrete Barrier Element		1
-----	Threaded rod		3

ACCEPTANCE

FHWA Acceptance Letter B-122, October 2, 2003.

BOLTED-DOWN PORTABLE F-SHAPE CONCRETE BARRIER

SWC11



SHEET NO.

DATE:

2 of 4

10/22/2008

REFERENCES

Polivka, K.A., Faller, R.K., Rohde, J.R., Holloway, J.C., Bielenberg, B.W., and Sicking, D.L., *Development and Evaluation of a Tie-Down System for the Redesigned F-Shape Concrete Temporary Barrier*, Final Report to the Midwest State's Regional Pooled Fund Program, Transportation Research Report No. TRP-03-134-03, Project No. SPR-3(017)- Year 13, Project Code: RPF-03-06, Midwest Roadside Safety Facility, University of Nebraska-Lincoln, August 22, 2003.

Bielenberg, R.W., Faller, R.K., Sicking, D.L., Rohde, J.R., and Reid, J.D., *Tie-Downs and Transitions for Temporary Concrete Barriers*, Paper No. 06-1276, Transportation Research Record No. 1984, Journal of the Transportation Research Board, TRB AFB20 Committee on Roadside Safety Design, Transportation Research Board, Washington D.C., January 2006.

CONTACT INFORMATION

Midwest Roadside Safety Facility
E527 Nebraska Hall
Lincoln, NE 68588-0529
(402) 472-0965
Email: mwrsf@unl.edu
Website: <http://mwrsf.unl.edu/>



BOLTED-DOWN PORTABLE F-SHAPE CONCRETE BARRIER



SWC11

SHEET NO.

DATE:

3 of 4

10/22/2008

PAGE INTENTIONALLY LEFT BLANK

BOLTED-DOWN PORTABLE F-SHAPE CONCRETE BARRIER

SWC11



SHEET NO.

DATE:

4 of 4

10/22/2008