

PLAN

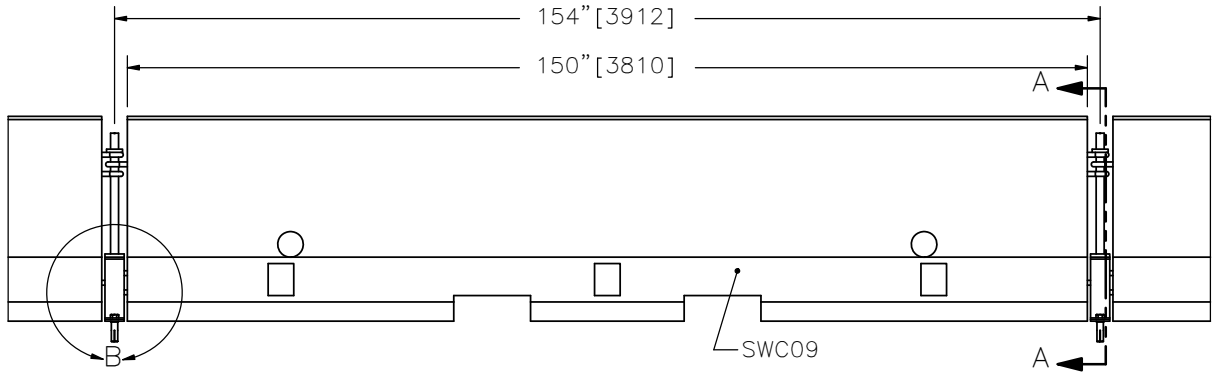

ELEVATION

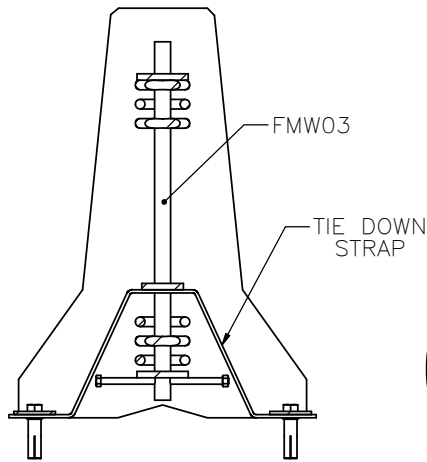

SECTION A-A  
SCALE 1 : 15

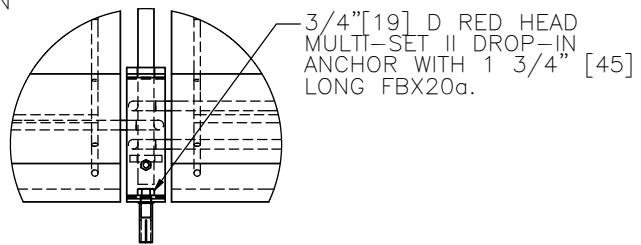

DETAIL B  
SCALE 1 : 15

NOTE: ACCEPTABLE SCREW-IN ANCHOR ALTERNATIVES FOR THE DROP-IN ANCHOR:  
 (1) 3/4" [19] D RED HEAD LARGE DIAMETER TAPCON(LDT),  
 4 1/2" [114] MINIMUM LENGTH  
 (2) 3/4" [19] D SIMPSON TITEN HO, 5" [127] MINIMUM LENGTH

TIE-DOWN STRAP SYSTEM FOR F-SHAPE CONCRETE BARRIER



SWC10

SHEET NO.

DATE:

1 of 4

10/22/2008

## SPECIFICATIONS

Components shall be formed from ASTM A36/A36M steel plate and zinc-coated according to AASHTO M111 (ASTM A123). No punching, drilling or cutting is permitted after the bracket is zinc-coated.

Dimension tolerances not shown or implied are intended to be those consistent with the proper functioning of the part, including its appearance and accepted manufacturing practices.

## INTENDED USE

Tie-Down Strap System for F-Shape Concrete Barriers (SWC10) is a non-proprietary system and is to be used as a work-zone barrier to protect traffic and workers. Tie-Down Strap System for F-Shape Concrete Barriers should be used in locations where a dynamic deflection of 33 1/2" [850] or less is acceptable and where a working width of 57 1/2" [1460] is provided. The Tie-Down Strap System for F-Shape Concrete Barriers may be used with a minimum gap of 6" [150] between the backside of the barrier and the edge of the bridge deck. The Tie-Down System was designed for use in concrete with a minimum compressive strength of 4,000 psi [28 MPa] and should not be placed in asphalt. The Tie-Down Strap is only intended for use with the redesigned and tested Portable F-Shape Temporary Concrete Barrier Element (SWC09) and the Temporary Barrier Connector Pin with Retaining Bolt (FMW03). The Tie-Down Strap System for F-Shape Concrete Barriers is TL-3 NCHRP 350 accepted.

## COMPONENTS

Unit Length = 154" [3912]

DESIGNATOR	COMPONENT	SYSTEM	NUMBER
SWC09	Portable F-Shape Concrete Barrier		1
FMW03	Portable Concrete Barrier Connector Pin with Retaining Bolt		1
FBX20a	Hex Head Bolt		1
-----	Red Head Multi-Set II Drop-in Anchors		2
-----	Tie Down Strap		1

## ACCEPTANCE

FHWA Acceptance Letter B-112, March 14 2003.

## REFERENCES

Bielenberg, B.W., Faller, R.K., Reid, J.D., Holloway, J.C., Rohde, J.R., and Sicking, D.L., *Development of a Tie-Down System for Temporary Concrete Barriers*, Final Report to the Midwest State's Regional Pooled Fund Program, Transportation Research Report No. TRP-03-115-02, Project No. SPR-3(017)-Year 9, Midwest Roadside Safety Facility, University of Nebraska-Lincoln, August 16, 2002.

## TIE-DOWN STRAP SYSTEM FOR F-SHAPE CONCRETE BARRIER

# SWC10



SHEET NO.

DATE:

2 of 4

10/22/2008

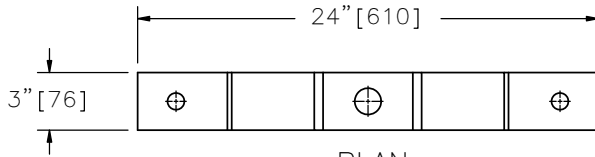

PLAN

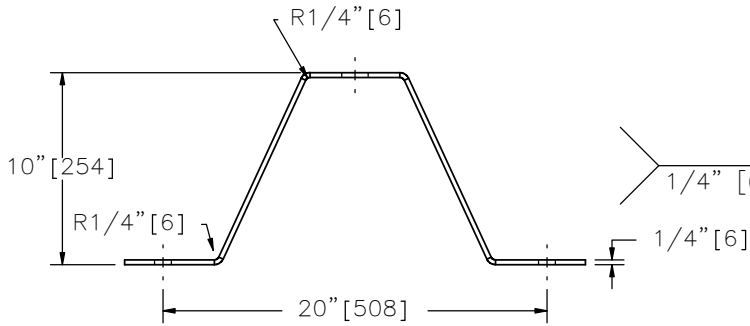

SIDE

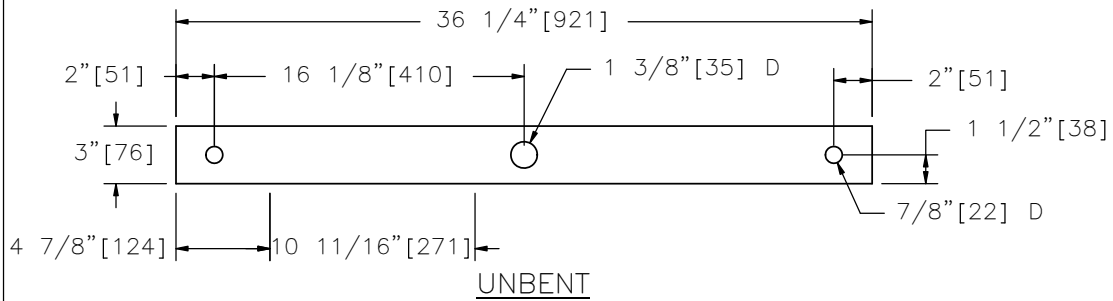
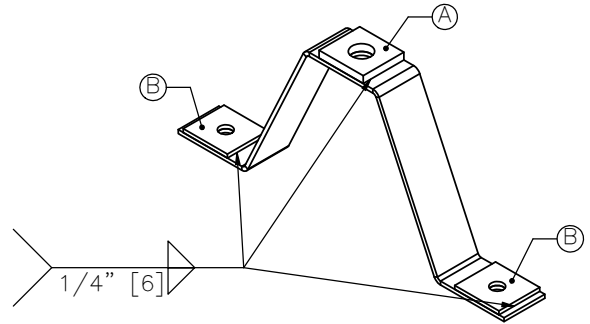

UNBENT

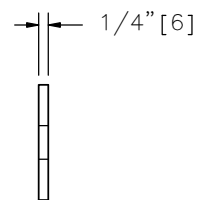
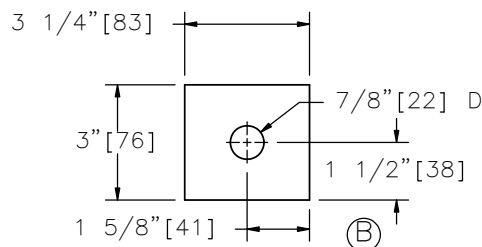
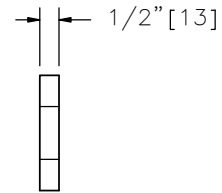
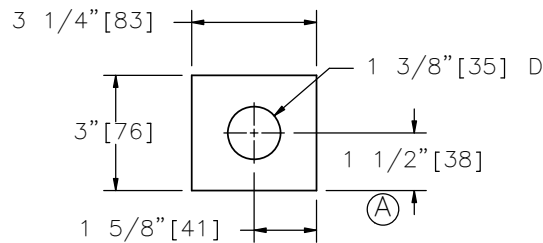

2 REQUIRED

NOTE: All components are ASTM A36/A36MI

## TIE-DOWN STRAP SYSTEM FOR F-SHAPE CONCRETE BARRIER



# SWC10

SHEET NO.

DATE:

3 of 4

10/22/2008

## REFERENCES

Bielenberg, B.W., Faller, R.K., Reid, J.D., Holloway, J.C., Rohde, J.R., and Sicking, D.L., *Development of a Tie-Down System for Temporary Concrete Barriers*, Final Report to the Midwest State's Regional Pooled Fund Program, Transportation Research Report No. TRP-03-115-02, Project No. SPR-3(017)-Year 9, Midwest Roadside Safety Facility, University of Nebraska-Lincoln, August 16, 2002.

Bielenberg, B.W., Faller, R.K., Reid, J.D., Rohde, J.R., and Sicking, D.L., *Design and Testing of Tie-Down Systems for Temporary Barriers*, Paper No. 03-3146, Transportation Research Record No. 1851, Transportation Research Board, National Research Council, Washington, D.C., January 2003. pp. 83-94.

Bielenberg, R.W., *Dynamic Component Testing of Potential Alternative Anchors for the F-Shape Concrete Barrier Steel Strap Tie-Down System*, Final Report (Letter Report) to the Midwest State's Regional Pooled Fund Program, Transportation Research Report No. TRP-03-182-07, Midwest Roadside Safety Facility, University of Nebraska-Lincoln, April 9, 2007.

Midwest States' Pooled Fund Progress Report for April 2006 to August 2006, Email Subject: *F-shape Barrier Strap Tie-Down Update*, Consulting Summary, July 7, 2006.

## CONTACT INFORMATION

Midwest Roadside Safety Facility  
E527 Nebraska Hall  
Lincoln, NE 68588-0529  
(402) 472-0965  
Email: [mwrfsf@unl.edu](mailto:mwrfsf@unl.edu)  
Website: <http://mwrfsf.unl.edu/>



## TIE-DOWN STRAP SYSTEM FOR F-SHAPE CONCRETE BARRIER

# SWC10



SHEET NO.

DATE:

4 of 4

10/22/2008