

FREE-STANDING, H-PILE, STEEL TEMPORARY BARRIER SYSTEM



SWM08

SHEET NO.

DATE:

1 of 6

8/23/2007

## INTENDED USE

Steel H-Section Temporary Barrier should be used in locations where a maximum dynamic deflection of 17 9/16" [446] or less is acceptable. This system is TL-3 NCHRP 350 accepted.

## COMPONENTS

Unit Length = 240" [6096]

DESIGNATOR	COMPONENT	SYSTEM	NUMBER
a	Top H-Pile section		1
b	Bottom H-Pile section		1
c	Vertical straps		10
d	Traffic side top connection angle		6
e	Non-traffic side connection plate (outside)		1
f	Non-traffic side connection plate (inside)		2
g	Traffic side connection plate (inside)		1
-	3/4"[19] x 2 3/4"[70] H.T.S. bolts w/washer		32

## ACCEPTANCE

FHWA Acceptance Letter B-117, September 12, 2003.

## REFERENCES

Faller, R.K., Post, E.R., Pfeifer, B.G., and Holloway, J.C. *Full-Scale Vehicle Crash Test on the Iowa Steel Temporary Barrier Rail*, Final Report to the Iowa Department of Transportation, Report No. TRP-03-20-89, Civil Engineering Department, University of Nebraska-Lincoln, December 1989.

## CONTACT INFORMATION

Midwest Roadside Safety Facility  
E527 Nebraska Hall  
Lincoln, NE 68588-0529  
(402) 472-0965  
Email: [mwrsf@unl.edu](mailto:mwrsf@unl.edu)  
Website: <http://mwrsf.unl.edu/>



## FREE-STANDING, H-PILE, STEEL TEMPORARY BARRIER SYSTEM

# SWM08

SHEET NO.

DATE:

2 of 6

8/23/2007



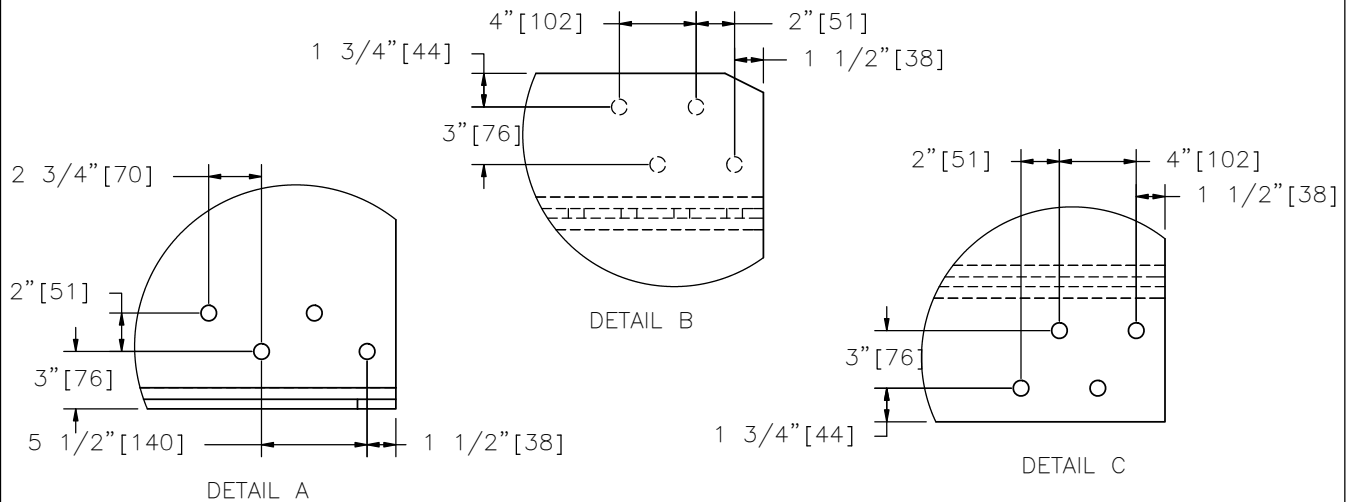
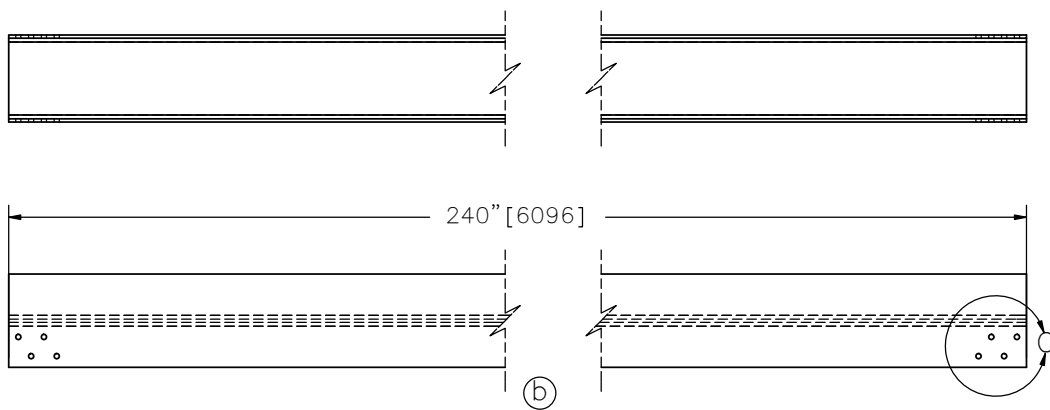
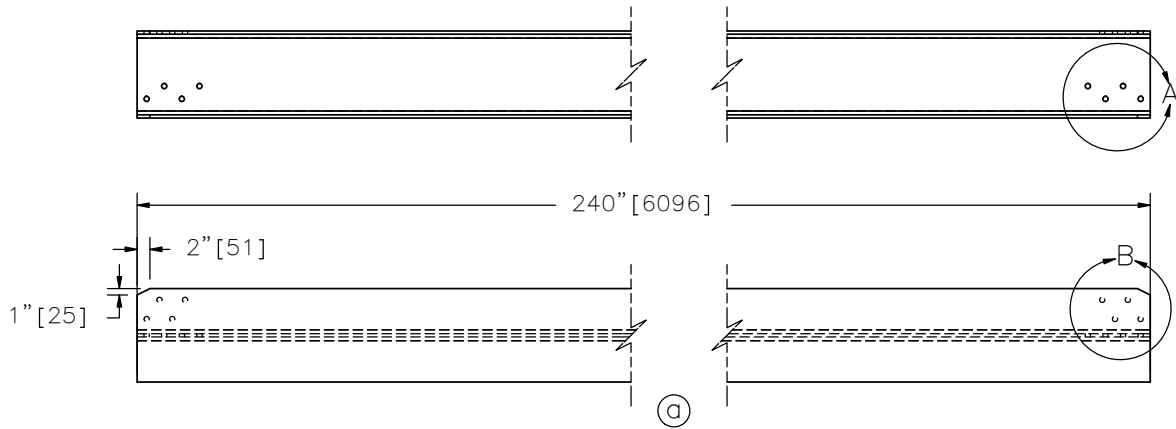

ALL HOLES IN DETAILS A,B,&C ARE 13/16" [21] DIAMETER

## FREE-STANDING, H-PILE, STEEL TEMPORARY BARRIER SYSTEM



# SWM08

SHEET NO.

DATE:

3 of 6

8/23/2007

PAGE INTENTIONALLY LEFT BLANK

FREE-STANDING, H-PILE, STEEL TEMPORARY BARRIER SYSTEM

**SWM08**



SHEET NO.

DATE:

4 of 6

8/23/2007

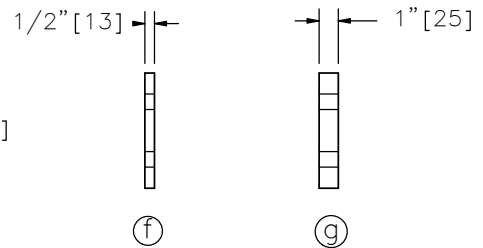
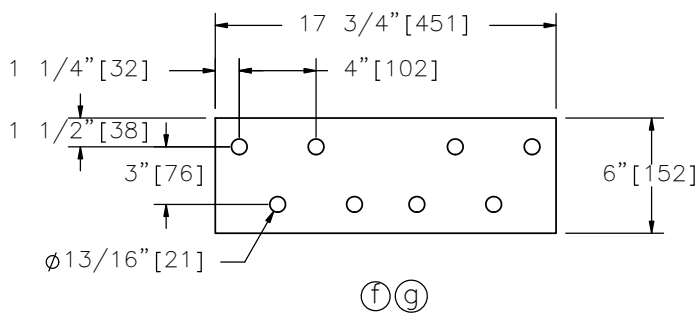
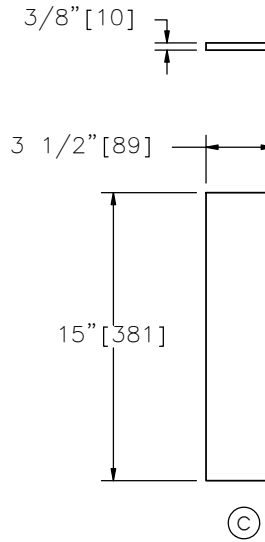
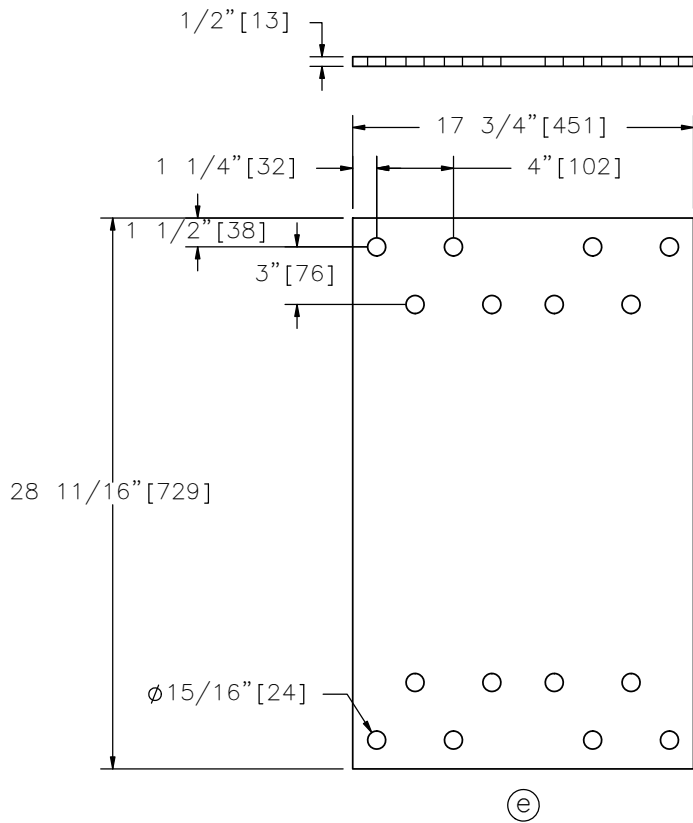
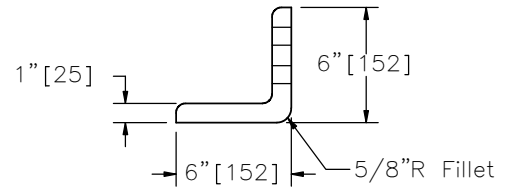
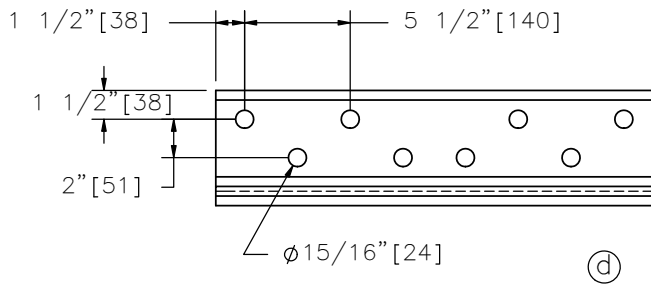

FREE-STANDING, H-PILE, STEEL TEMPORARY BARRIER SYSTEM



SWM08

SHEET NO.

DATE:

5 of 6

8/23/2007

PAGE INTENTIONALLY LEFT BLANK

FREE-STANDING, H-PILE, STEEL TEMPORARY BARRIER SYSTEM

**SWM08**



SHEET NO.

DATE:

6 of 6

8/23/2007