

PLAN VIEW

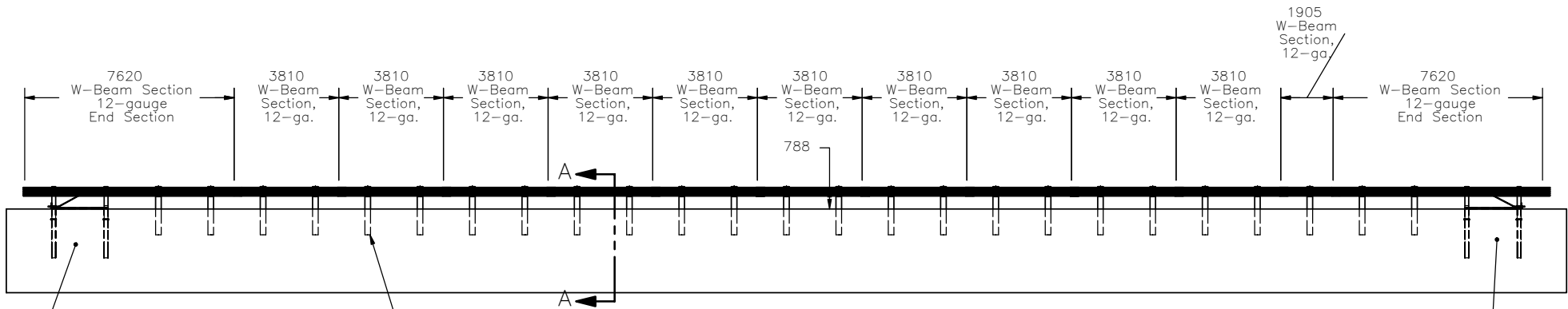

PROFILE VIEW

BCT posts in 1829 long (galvanized) foundation tubes, ground line strut, and BCT cable anchor

1753 long round posts with 152x305x362 routed blockouts

BCT posts in 1829 long (galvanized) foundation tubes, ground line strut, and BCT cable anchor



Midwest Roadside Safety Facility

Round-Post MGS with Ponderosa Pine System Layout

SHEET: 1 of 9

DATE: 06/20/2006

DRAWN BY: GEP

DWG. NAME: FPL_MGS_PP_R4-metric

SCALE: None UNITS: mm

REV. BY: CME

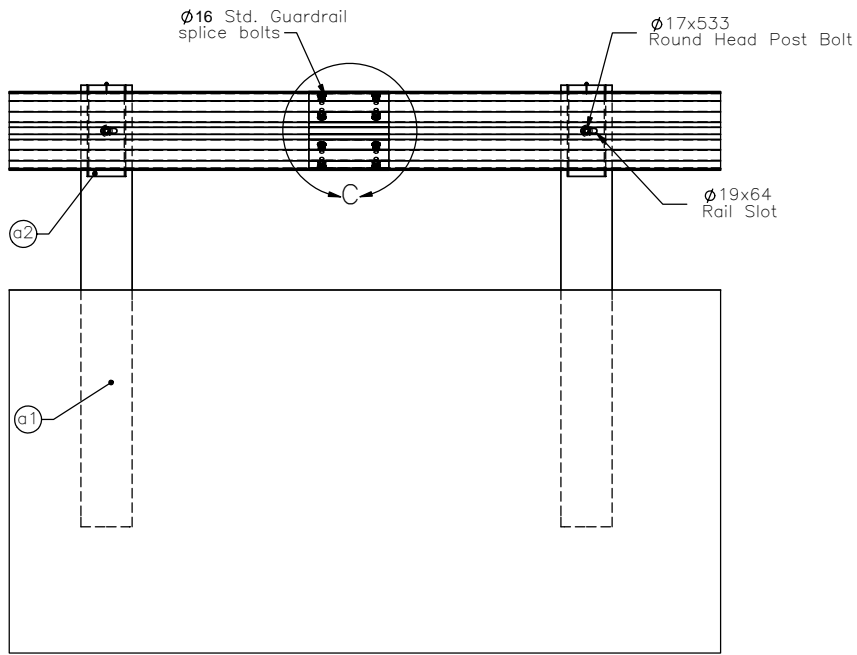

SPLICE DETAIL

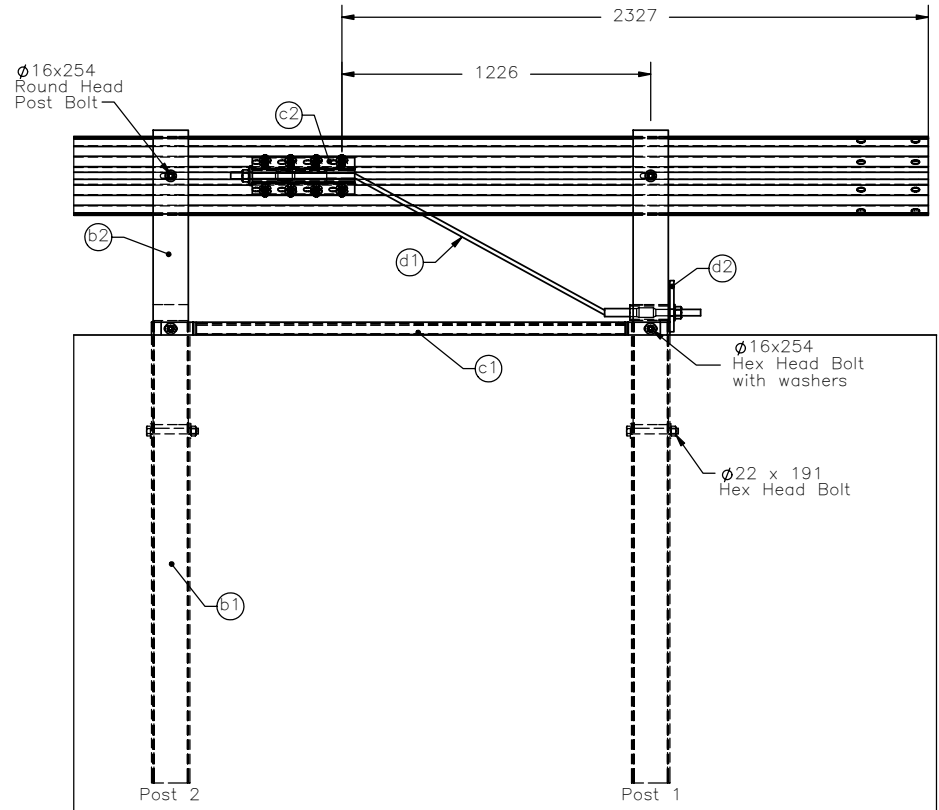

END RAIL DETAIL

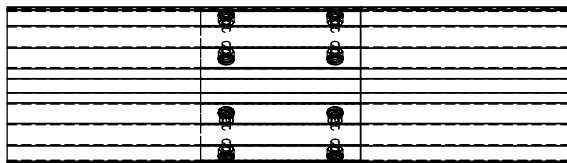

DETAIL C
SCALE 1 : 15



Midwest Roadside
Safety Facility

Round-Post MGS

End Rail Detail
Splice Detail

DWG. NAME.
FPL_MGS_PP_R4--metric

SCALE: None
UNITS: mm

SHEET:
2 of 9
DATE:
06/20/2006
DRAWN BY:
GEP
REV. BY:
CME

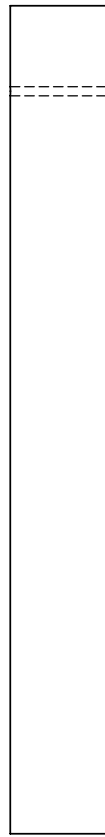
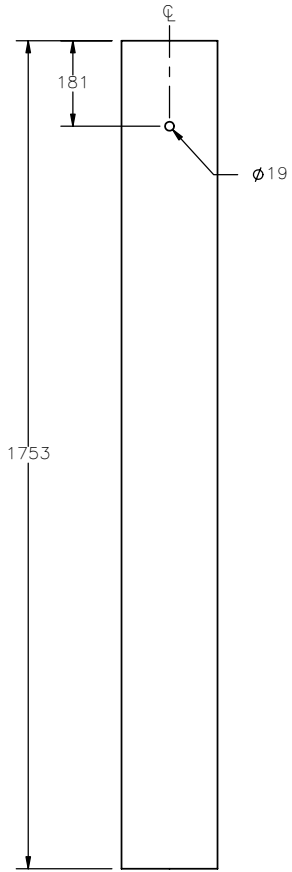
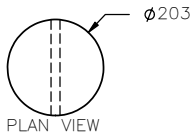

Ponderosa Pine Round Post
Part a1

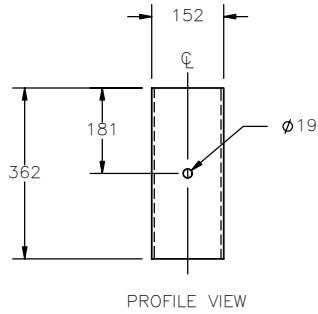
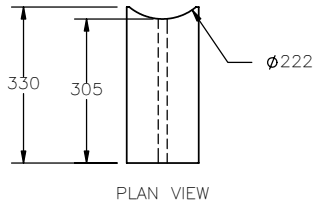

Ponderosa Pine Blockout
Part a2

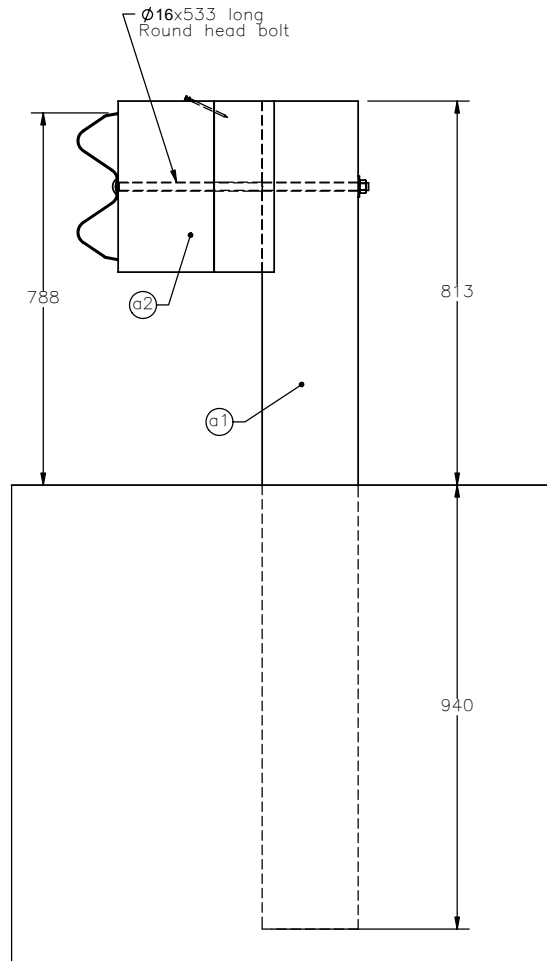

SECTION A-A



Midwest Roadside
Safety Facility

Round-Post MGS
Post 3-27 Detail

DWG. NAME.
FPL_MGS_PP_R4--metric

SCALE: None
UNITS: mm

SHEET:
3 of 9
DATE:
06/20/2006
DRAWN BY:
GEP
REV. BY:
CME

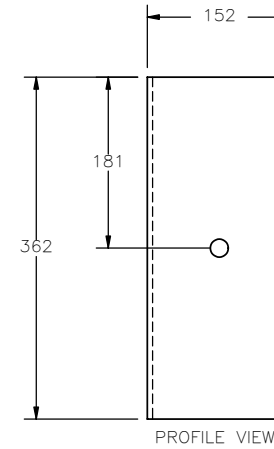
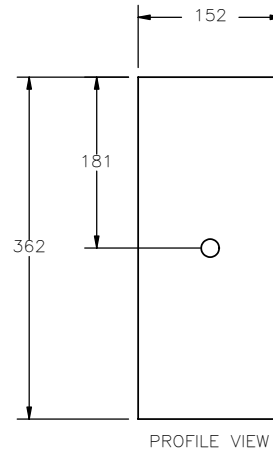
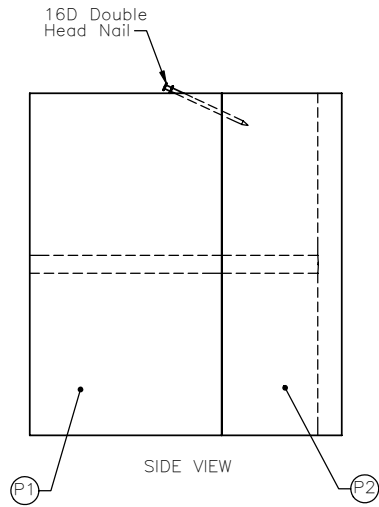
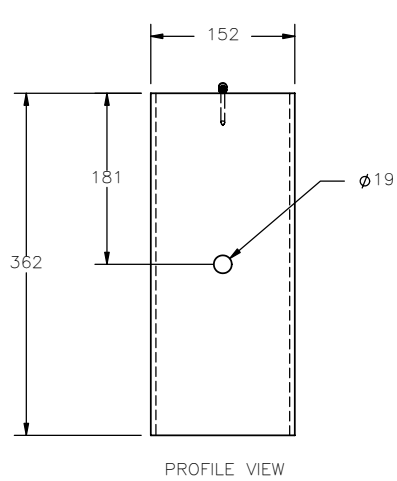
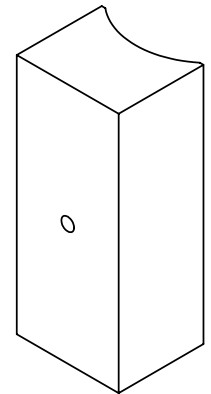
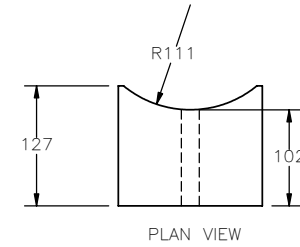
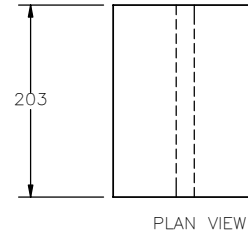
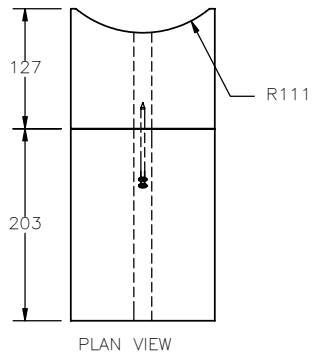

152x203x362 Blockout Part 1

152x127x362 Blockout Part 2



Midwest Roadside Safety Facility

Round-Post MGS

Segmented Blockout Option

SHEET:
4 of 9

DATE:
06/20/2006

DRAWN BY:
GEP

DWG. NAME:
FPL_MGS_PP_R4--metric

SCALE: None
UNITS: mm

REV. BY:
CME

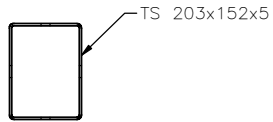

PLAN VIEW

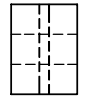

PLAN VIEW

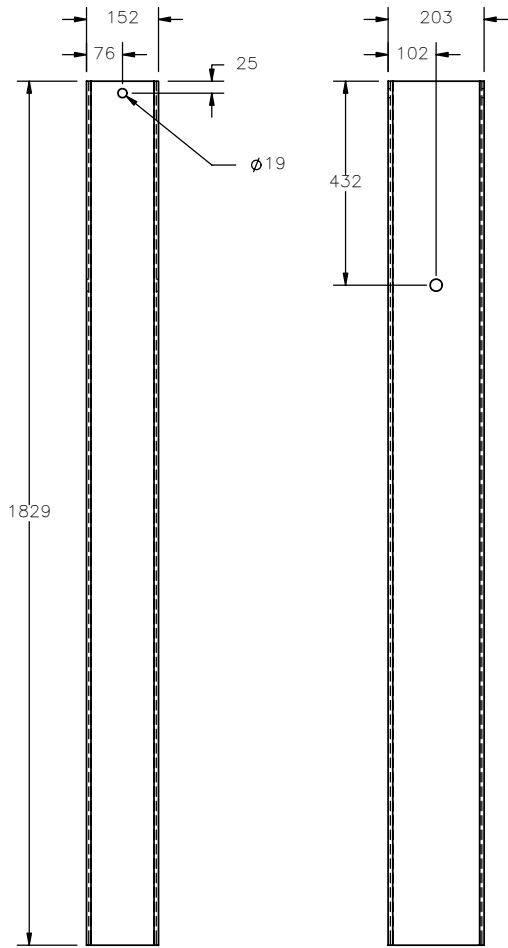

PROFILE VIEW

SIDE VIEW

Foundation Tube
Part b1

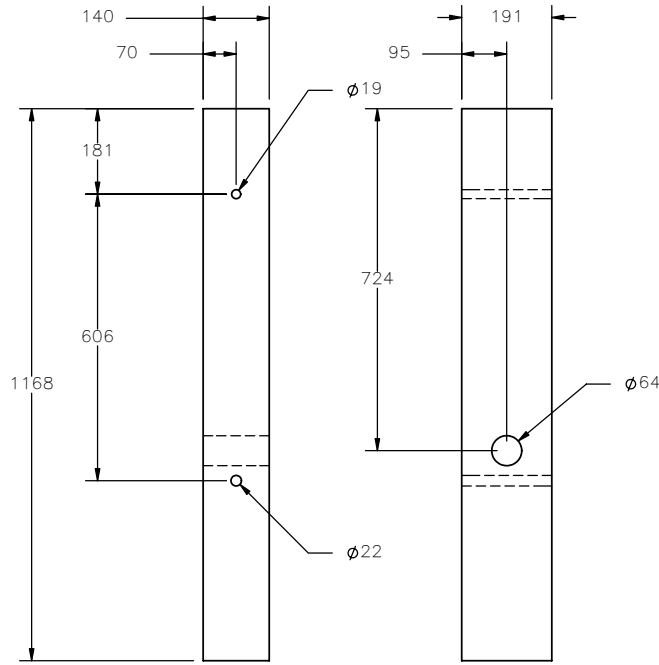

PROFILE VIEW

SIDE VIEW

BCT (MGS) Timber Post
Part b2

Post Number	Post Reference Number
3	818
4	821
5	823
6	808
7	832
8	802
9	834
10	831
11	817
12	803
13	827
14	801
15	819
16	804
17	807
18	829
19	833
20	825
21	816
22	830
23	806
24	805
25	835
26	822
27	820



Midwest Roadside
Safety Facility

Round-Post MGS

BCT Timber Posts &
Foundation Tube Detail

SHEET:
5 of 9

DATE:
06/20/2006

DRAWN BY:
GEP

DWG. NAME:
FPL_MGS_PP_R4--metric

SCALE: None
UNITS: mm

REV. BY:
CME

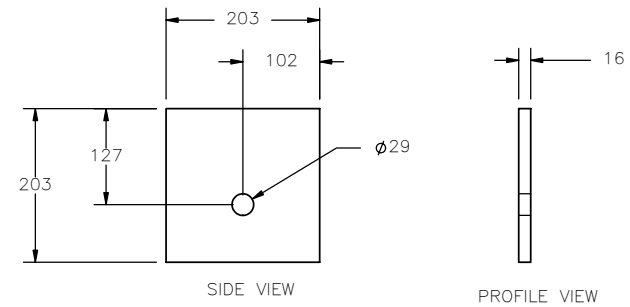
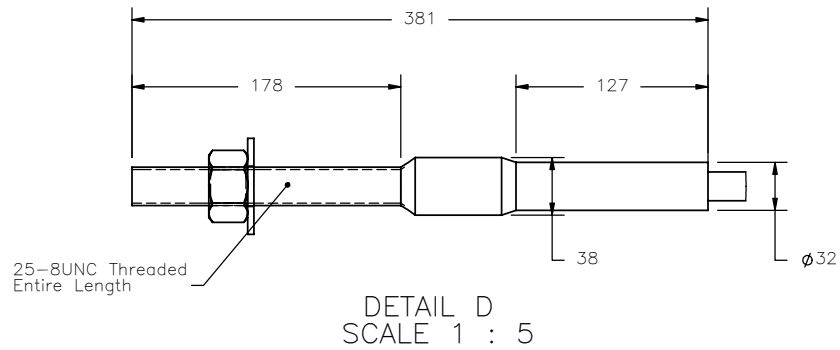
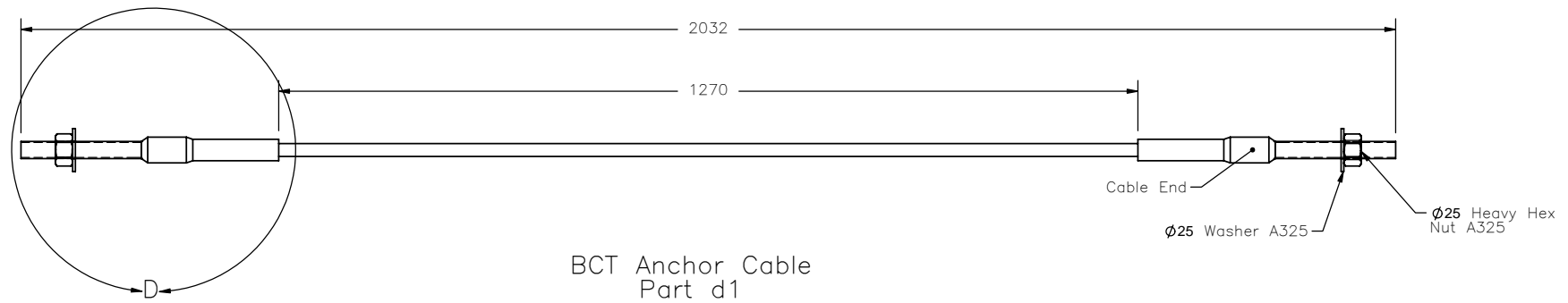

Midwest Roadside
Safety Facility

<p>Round-Post MGS</p> <p>BCT Anchor Cable Detail</p>	DWG. NAME.	SCALE: None	REV. BY:
	FPL_MGS_PP_R4--metric	UNITS: mm	CME
	<p>SHEET: 6 of 9</p> <p>DATE: 06/20/2006</p> <p>DRAWN BY: GEP</p>		

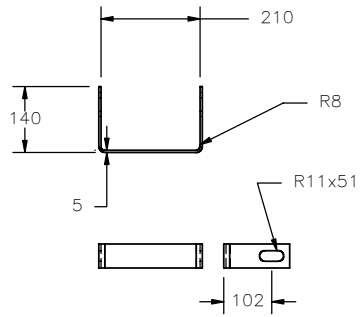

Yoke Detail

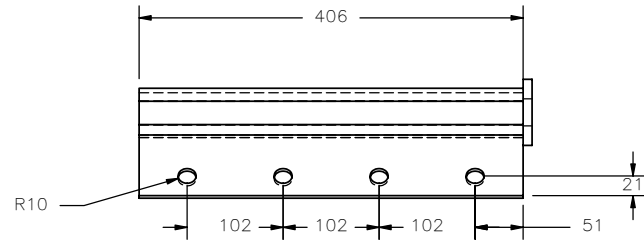

Anchor Bracket
Part c2

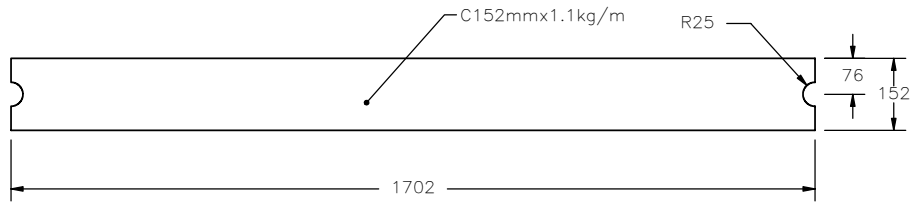

Strut Detail

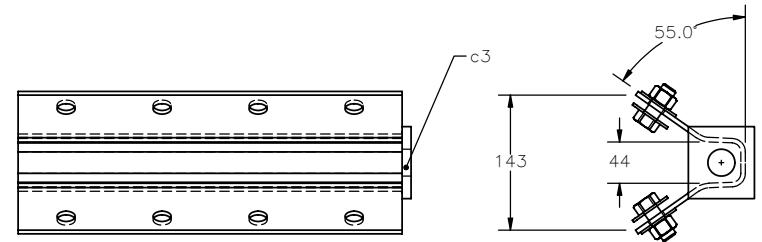

Anchor Bracket
Bearing Plate
Part c3

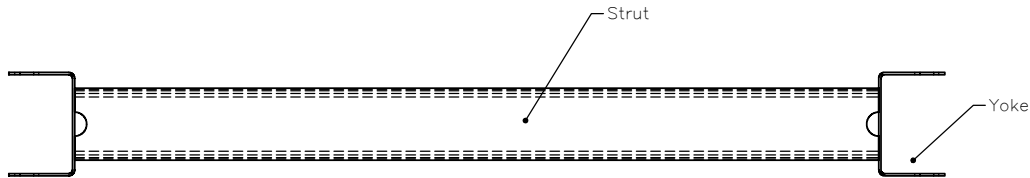

PLAN VIEW

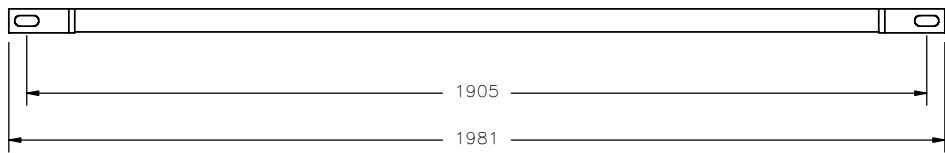
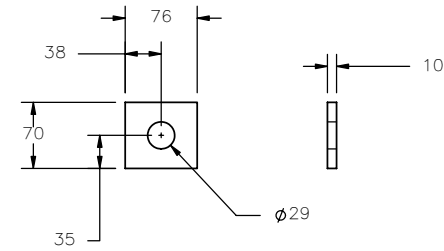

PROFILE VIEW

Ground Strut
Part c1



Midwest Roadside
Safety Facility

Round-Post MGS

Ground Strut & Anchor
Bracket Details

DWG. NAME.
FPL_MGS_PP_R4--metric

SCALE: None
UNITS: mm

SHEET:
7 of 9
DATE:
06/20/2006
DRAWN BY:
GEP
REV. BY:
CME

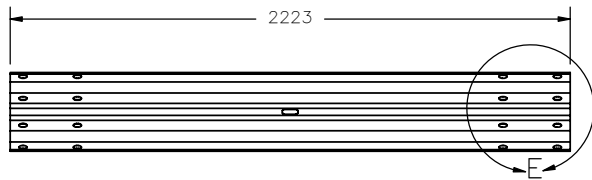

1905 W-Beam Section, 12 gauge

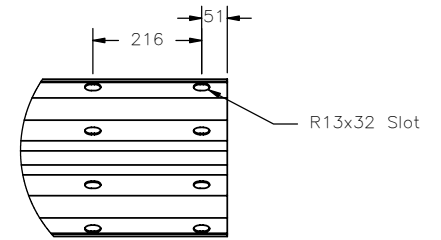

DETAIL E
SCALE 1 : 15

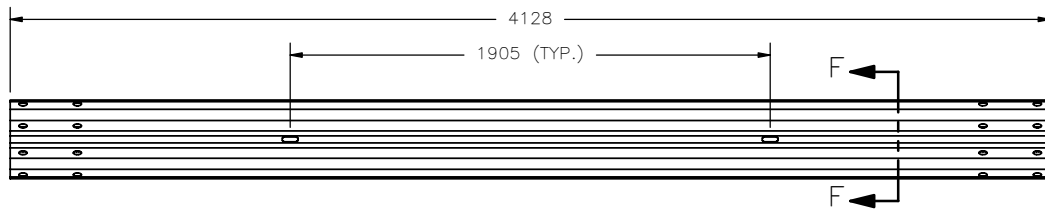

3810 W-Beam Section, 12 gauge

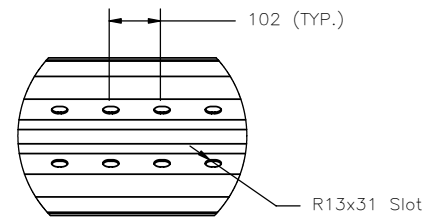

DETAIL G
SCALE 1 : 15

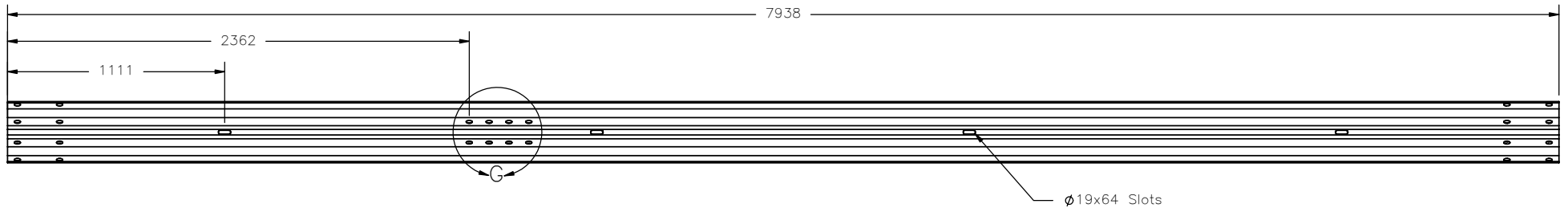

7620 W-Beam Section, 12 gauge, End Section



Midwest Roadside
Safety Facility

Round-Post MGS
Rail Section Details

DWG. NAME.
FPL_MGS_PP_R4-metric

SCALE: None
UNITS: mm

SHEET:
8 of 9
DATE:
06/20/2006
DRAWN BY:
GEP
REV. BY:
CME

Guardrail Post Grading Criteria

General

All posts shall meet the current quality requirements of the American National Standards Institute (ANSI) 05.1, "Wood Poles" except as supplemented herein:

Manufacture:

All posts shall be smooth shaved by machine. No "ringing" of the posts, as caused by improperly adjusted peeling machine, is permitted. All outer and inner bark shall be removed during the shaving process. All knots and knobs shall be trimmed smooth and flush with the surface of the posts. The guardrail posts will be a minimum of 1.75 m (69 in.) long. The use of peeler cores is prohibited.

Ground—line:

The ground—line, for the purpose of applying these restrictions of ANSI 05.1 that reference the ground—line, shall be defined as being located 914 mm (36 in.) from the butt end of each post.

Size:

The size of the posts shall be classified based on their diameter at the ground—line and their length and will be species specific. The ground—line diameter shall be specified by diameter in 6 mm (¼ in.) breaks. The length shall be specified in 300 mm (1 ft) breaks. Dimension shall apply to fully seasoned posts. When measured between their extreme ends, the post shall be no shorter than the specified lengths but may be up to 75 mm (3 in.) longer.

Scars:

Scars are permitted in the middle third as defined in ANSI 05.1 provided that the depth of the trimmed scar is not more than (1 in.).

Shape and Straightness:

All timber posts shall be nominally round in cross section. A straight line drawn from the centerline of the top to the center of the butt of any post shall not deviate from the centerline of the post more than 32 mm (1¼ in.) at any point. Posts shall be free from reverse bends.

Splits and Shakes:

Splits or ring shakes are not permitted in the top two thirds of the post. Splits not to exceed the diameter in length are permitted in the bottom third of the post. A single shake is permitted in the bottom third, provided it is not wider than one—half the butt diameter.

Decay:

Allowed in knots only.

Holes:

Pin holes 1 mm (1/16 in.) or less are not restricted.

Slope of Grain:

1 in 10.

Compression Wood:

Not allowed, in the outer 25 mm (1 in.) or if exceeding ¼ of the radius.

Timber Spacers:

When timber spacers are required, the timber species shall be the same as those furnished for the timber posts. The size and hole location shall be as shown on the plans, with a tolerance of 6 mm (¼ in.). Spacers shall be of medium grain, at least four (4) rings per inch on one end, and free from splits, shakes, compression wood or decay in any form. Individual knots, knot clusters or knots in the same cross section of a face are permitted, provided they are sound or firm, and are limited in cumulative width (when measured between lines parallel to the edges) to no more than one—half the width of the face. Wane or the absence of wood is limited to one—third of the face on no more than 10 percent of the lot. Slope of grain deviation is limited to one in six. The material may be rough sawn or surfaced, full size, hit or miss, with a tolerance of 6 mm (¼ in.) for all dimensions.

Treatment:

Treating – American Wood—Preservers' Association (AWPA) – Book of Standards (BOS) U1—05 use category system UCS: user specification for treated wood; commodity specification B; Posts; Wood for Highway Construction must be met using the methods outlined in AWPA BOS T1—05 Section 8.2.

Each post treated shall have a minimum sapwood depth of 19 mm (¾ in.) as determined by examination of the tops and butts of each post. Material that has been air dried or kiln dried shall be inspected for moisture content in accordance with AWPA standard M2 prior to treatment. Tests of representative pieces shall be conducted. The lot shall be considered acceptable when the average moisture content does not exceed 25 percent. Pieces exceeding 29 percent moisture content shall be rejected and removed from the lot.

Species Specific Criteria

Ponderosa Pine:

Knot diameter for posts of Ponderosa Pine shall not exceed 102 mm (4 in.). Ring density for the species shall be at least 6 rings—per—inch as measured over a 76 mm (3 in.) distance. The diameter of the Ponderosa Pine posts shall be 203 mm (8 in.) at the ground line with an upper limit of 222 mm (8¾ in.).

	Round—Post MGS Grading Specifications		SHEET: 9 of 9
			DATE: 06/20/2006
Midwest Roadside Safety Facility	DWG. NAME: FPL_MGS_PP_R4—metric	SCALE: None UNITS: mm	DRAWN BY: GEP
			REV. BY: CME