

SECTION A-A
Lifting Slot

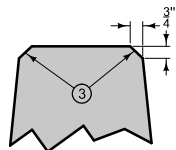

CHAMFER DETAIL

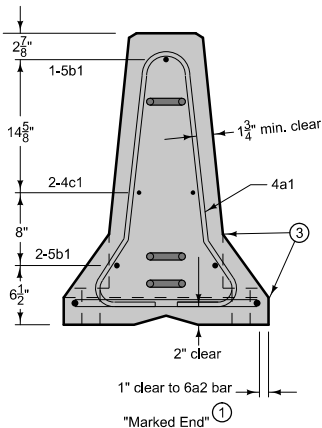

SECTION B-B
Stirrup Placement

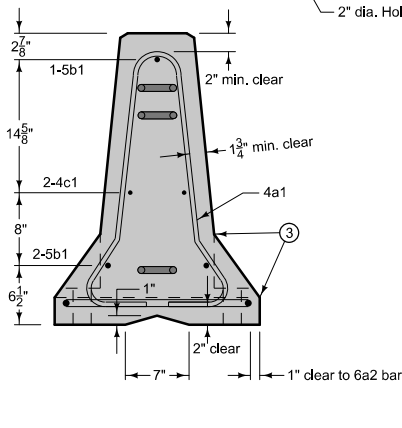

SECTION C-C
Stirrup Placement

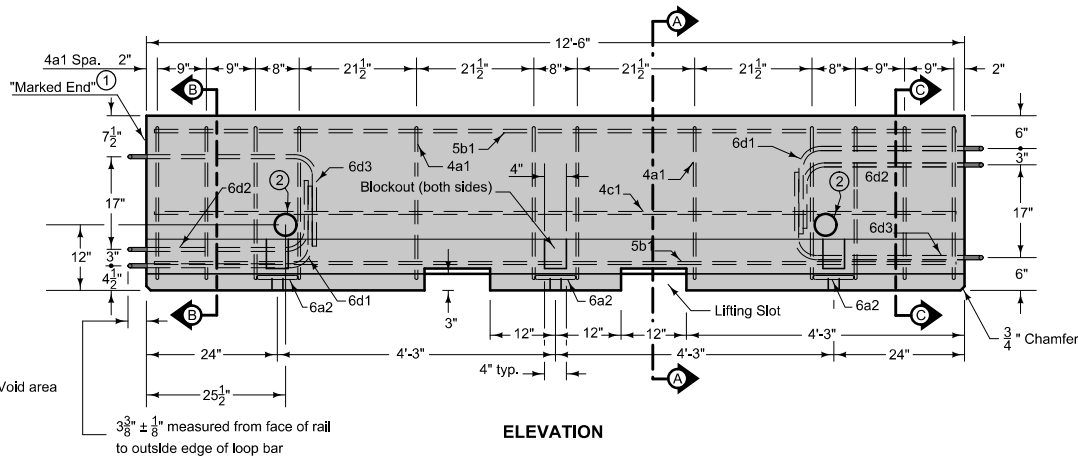

ELEVATION

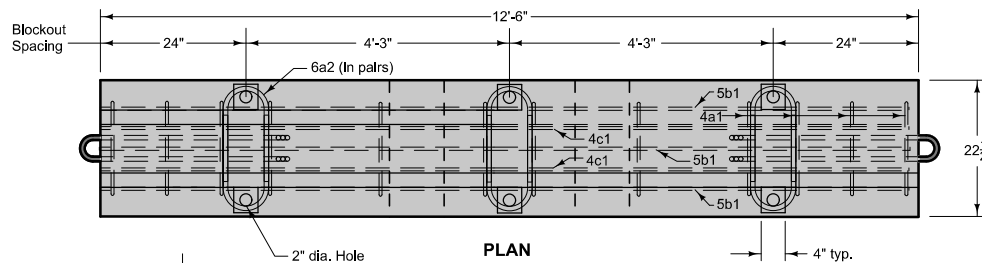

PLAN

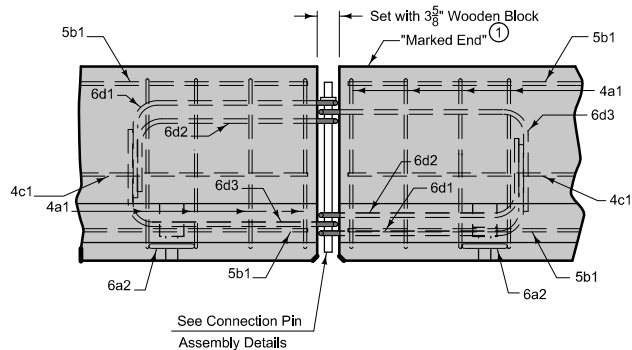

See Connection Pin
Assembly Details

BARRIER CONNECTION
(Elevation)

For loop bars 6d1, 6d2, and 6d3, use $\frac{3}{8}$ " smooth steel bars with a minimum yield strength of 60 ksi, a tensile strength of not less than 1.25 times the yield strength but a minimum of 80 ksi, a minimum 14% elongation in 8 inches, and passing a 180 degree bend test using a $\frac{3}{2}$ " pin bend diameter.

Install loops within $\frac{1}{8}$ " of the plan dimensions.

Use Grade 60, ASTM A615 for all other reinforcements. Do not lift or move using loop bars 6d1, 6d2 or 6d3.

Provide for an approved monitoring schedule with a person on call and available 24 hours a day, each day of the week, to realign barrier which has been struck. Initiate service within one hour of notification of need.

Unless stated otherwise in the plans, the barrier rail sections shall be the property of the Contractor. Remove from the site upon completion of work.

Following removal of anchorage, fill all holes with an approved non-shrink grout.

Tapered end section is not designed for use within 30 feet of traffic on facilities with speed limits 55 mph or greater, nor within 10 feet of traffic on facilities with speed limits 40 mph to 50 mph.

Estimated quantity of concrete for one taper section is 0.6 cubic yards.

Include the cost of anchorage, when required in the price bid for "Temporary Barrier Rail, Concrete".

① Permanently mark one end of each rail section with manufacturing information. The "marked end" is that end of the barrier having one loop bar at the top and two loop bars at the bottom. Include the following information in the marking:

- Manufacturer Identification
- Date Manufactured (Month and Year)
- BA-401 Type A

② Lifting hole, 4 inch diameter PVC Pipe.

③ 1 inch radius allowed.

Possible Contract Item:
Temporary Barrier Rail, Concrete

Possible Tabulation:
108-33

 Iowa Department of Transportation	REVISION
	1 04-16-13
STANDARD ROAD PLAN	BA-401
REVISIONS: Defined dropoff on sheet 3.	SHEET 1 of 4
 APPROVED BY DESIGN METHODS ENGINEER	
TEMPORARY BARRIER RAIL (PRECAST CONCRETE)	

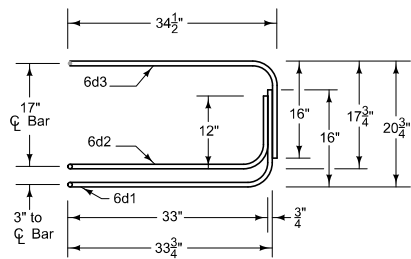

Elevation
(Marked end shown, invert for other end.)

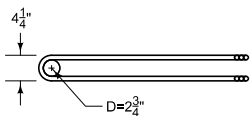

Plan
6d1, 6d2, 6d3

BENT BAR DETAILS
(Dimensions are out to out of bars unless otherwise noted.)

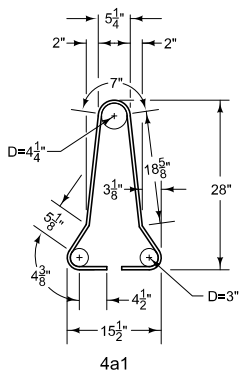

4a1

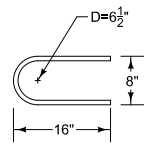

6a2

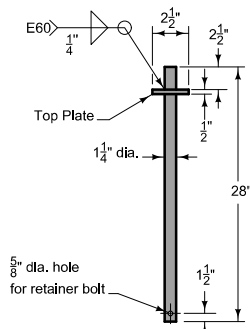

CONNECTION PIN
(A36 Steel - 10.9 lbs. each)

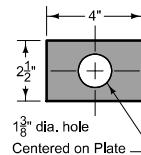

1/2" Top Plate

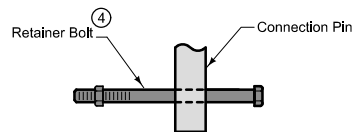

RETAINER BOLT & NUT
1/2" dia. bolt & nut
(ASTM A490, Grade 8)

CONNECTION PIN ASSEMBLY

- ④ Retainer bolt & nut are required for connections with 2-loop barriers (previous designs) or in conjunction with Strap Anchorage.
- ⑤ Furnish and install Barrier Markers. Attach to the barrier in a manner approved by the manufacturer. Markers to face oncoming traffic and match the adjacent edge line in color. Maintain the markers and promptly repair or replace any damaged or missing units. Include costs for furnishing, installing and maintaining markers in the price bid for "Temporary Barrier Rail, Concrete."

Per 12'-6" Barrier Section

REINFORCING A615 Gr. 60					
Bar	Bar Size	Shape	No. of Bars	Length Ft.	Weight Lbs.
4a1	4		12	6'-0"	48.1
6a2	6		6	35"	26.3
5b1	5		3	12'-2"	38.1
4c1	4		2	12'-2"	16.3
LOOP ASSEMBLY					
6d1	6		2	8'-5"	25.3
6d2	6		2	7'-7"	22.8
6d3	6		2	8'-6"	25.5

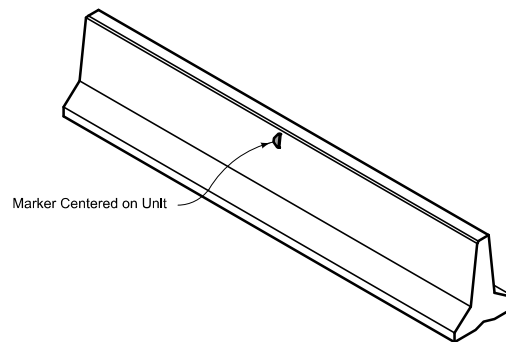
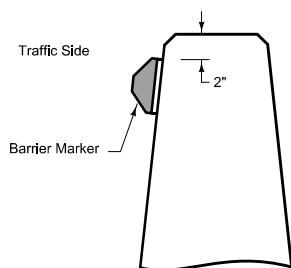

BARRIER MARKER PLACEMENT

⑤

 Iowa Department of Transportation	REVISION
	1 04-16-13
STANDARD ROAD PLAN	BA-401
REVISIONS: Defined dropoff on sheet 3.	SHEET 2 of 4
<i>Deanna Macfield</i> APPROVED BY DESIGN METHODS ENGINEER	
TEMPORARY BARRIER RAIL (PRECAST CONCRETE)	

STRAP ANCHORAGE

For use on:
Bridge Decks
PCC Pavement

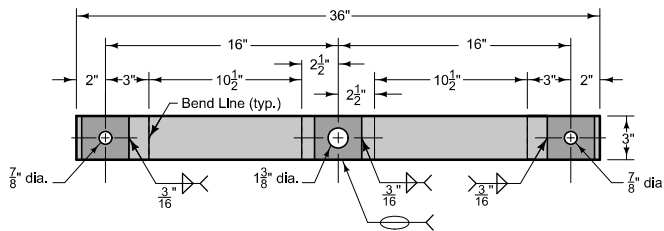

TIE-DOWN STRAP
(before bending)

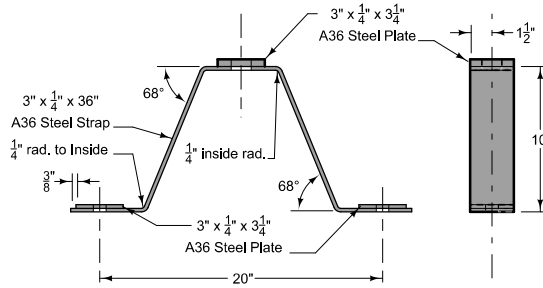

TIE-DOWN STRAP
(after bending)

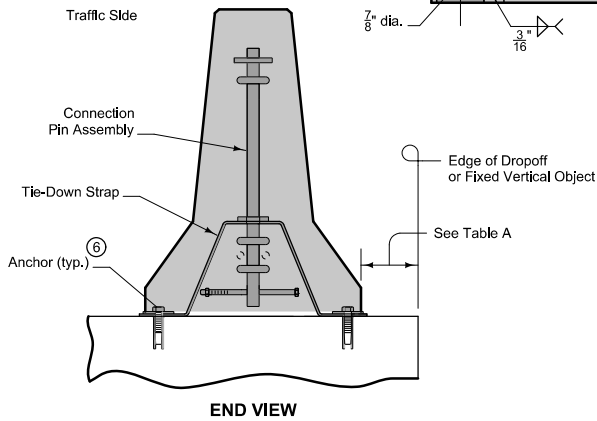

END VIEW

- ⑥ 3/4 inch Red Head Multi-Set II drop-in anchor with 3/4" dia. x 1 3/4" long ASTM A325 structural bolt OR Red Head Large Diameter Tapcon (3/4" dia. x 4 1/2" min.) OR Simpson Titen HD Wedge Bolt (3/4" dia. x 5" min.).
- ⑦ 3 stakes required per rail section.
- ⑧ Pre-drill holes for stakes with 1/8" core bit.

STAKE ANCHORAGE

For use on:
HMA Pavement (2" min. thickness)
Composite Pavement ⑧
PCC Pavement ⑧

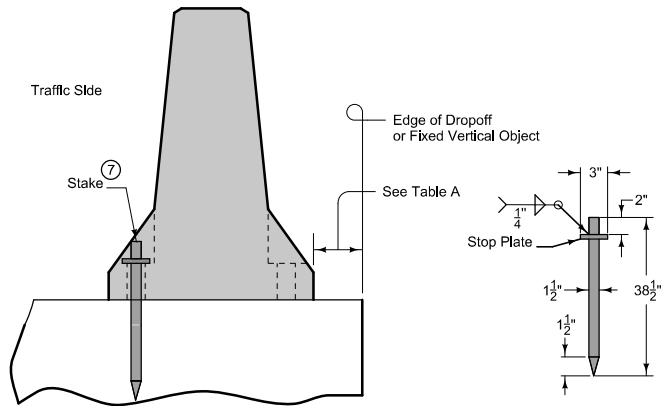

TYPICAL SECTION

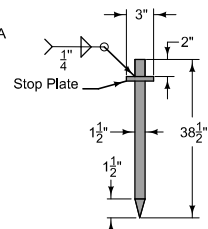

STAKE

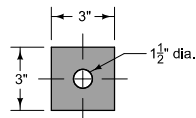

1/2" STOP PLATE

TABLE A
ANCHORAGE REQUIREMENTS

Obstacle	Dropoff Depth	Dropoff		
		Min. offset where TBR is Unanchored	Min. offset where TBR is Anchored	
Dropoff*	from pavement	≤ 24"	24"	6"
	> 24"	45"	6"	6"
Fixed vertical object	from bridge	≤ 3"	1"	N/A
	> 3"	45"	6"	6"
Fixed vertical object		N/A	24"	6"

* A dropoff is a slope of 2H:1V or steeper

<p>Iowa Department of Transportation</p> <p>STANDARD ROAD PLAN</p> <p>REVISIONS: Defined dropoff on sheet 3.</p>	REVISION 1 04-16-13
	<p>BA-401</p> <p>SHEET 3 of 4</p>

Deanna Macfild
APPROVED BY DESIGN METHODS ENGINEER

TEMPORARY BARRIER RAIL
(PRECAST CONCRETE)

TAPERED END SECTION

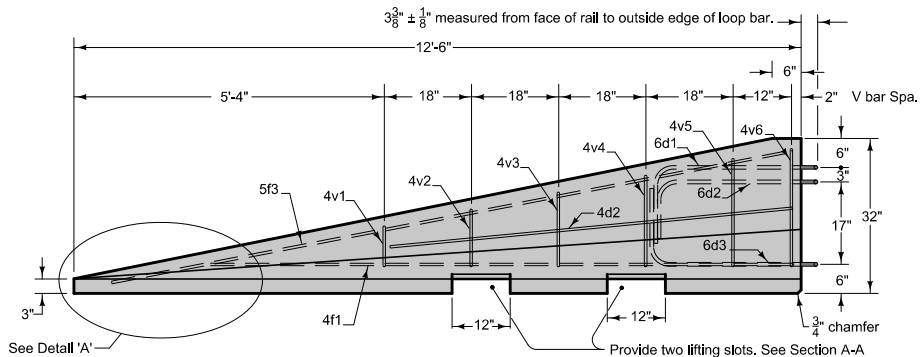

SIDE ELEVATION
(For connection to "marked end" of barrier.
Invert loop bars for other end.)

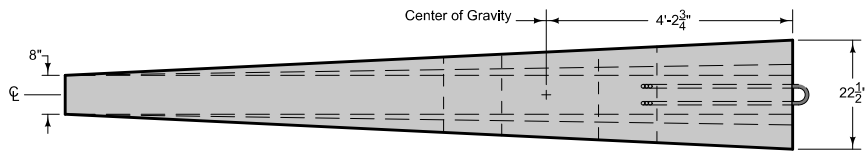

PLAN

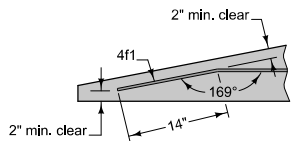

DETAIL 'A'

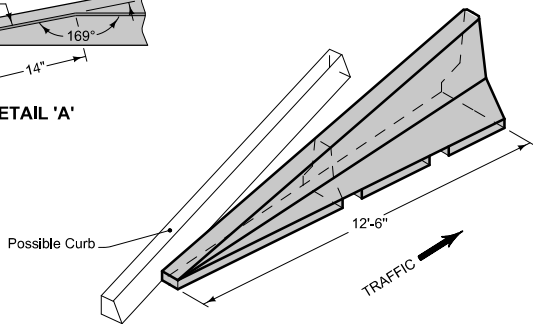

PERSPECTIVE VIEW

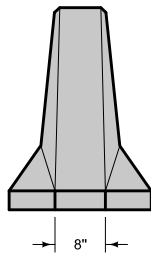

FRONT ELEVATION

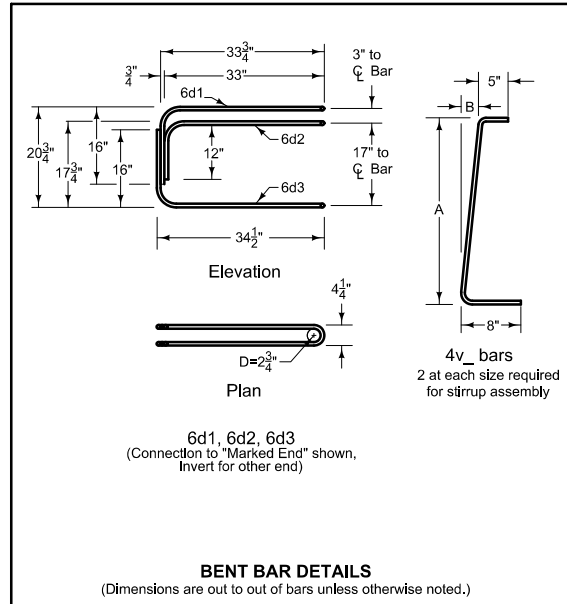

BENT BAR DETAILS
(Dimensions are out to out of bars unless otherwise noted.)

③ 1 inch radius allowed.

Per 12'-6" Barrier Taper Section

REINFORCING A615 Gr. 60					
Bar	Bar Size	Shape	No. of Bars	Length ft.	Weight lbs.
4v1	4	[2	23"	2.6
4v2	4	[2	26"	2.9
4v3	4	[2	30"	3.3
4v4	4	[2	33"	3.7
4v5	4	[2	3'-2"	4.2
4v6	4	[2	3'-4"	4.5
4f1	4	—	2	12'-0"	16.0
4f2	4	—	2	7'-6"	10.0
5f3	5	—	1	11'-9"	12.3
LOOP ASSEMBLY					
6d1	6	[1	8'-5"	12.6
6d2	6	[1	7'-7"	11.4
6d3	6	[1	8'-6"	12.8

Bar	A	B
4v1	10"	1"
4v2	13"	1 1/4"
4v3	17"	1 5/8"
4v4	20"	1 5/8"
4v5	24 1/2"	2 3/8"
4v6	27"	2 3/4"

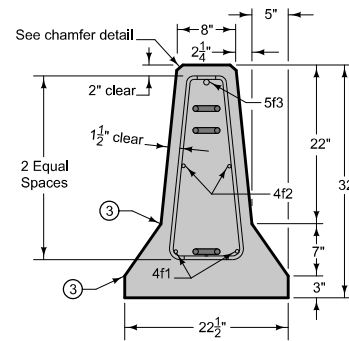

END SECTION

<p>Iowa Department of Transportation</p> <p>STANDARD ROAD PLAN</p> <p>REVISIONS: Defined dropoff on sheet 3.</p> <p><i>Deanna Macfield</i> APPROVED BY DESIGN METHODS ENGINEER</p>	REVISION 1 04-16-13
	<p>BA-401</p> <p>SHEET 4 of 4</p>

**TEMPORARY BARRIER RAIL
(PRECAST CONCRETE)**