

- NOTES: 1. ALL FILLETS SHALL HAVE A MINIMUM RADIUS OF 1/16 [2].
 2. IF THE BOLT EXTENDS MORE THAN 1/4 [6] FROM THE NUT THE BOLT SHOULD BE TRIMMED BACK.

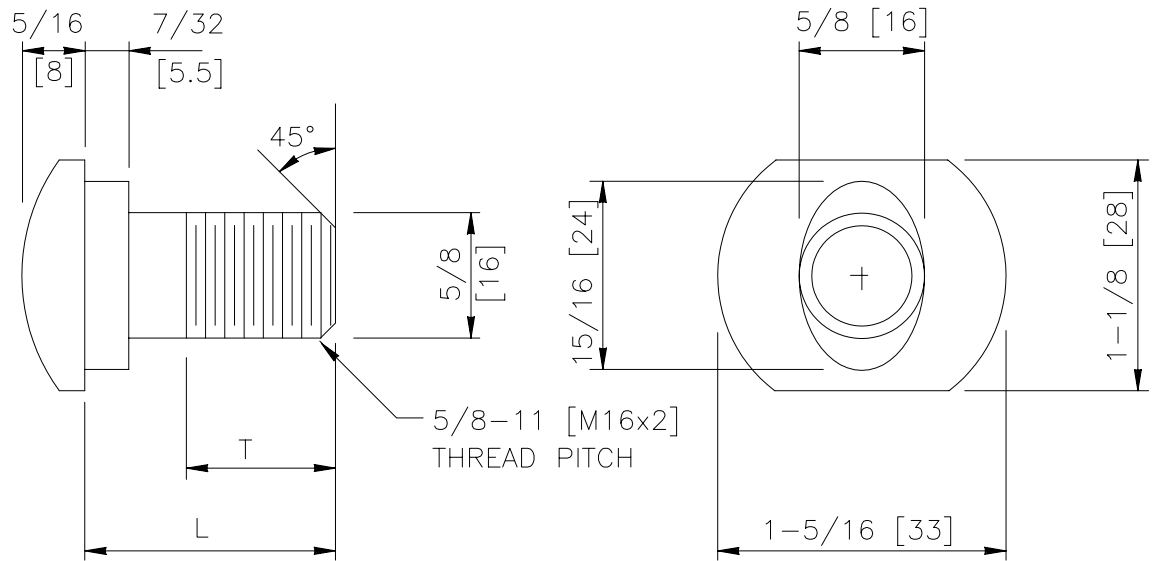

DESIGNATOR	L	T (MIN)
FBB01	1-1/4 [35]	1-1/8 [30]
FBB02	2 [50]	1-3/4 [45]
FBB03	10 [255]	4 [100]
FBB04	18 [460]	4 [100]
FBB05	25 [640]	4 [100]

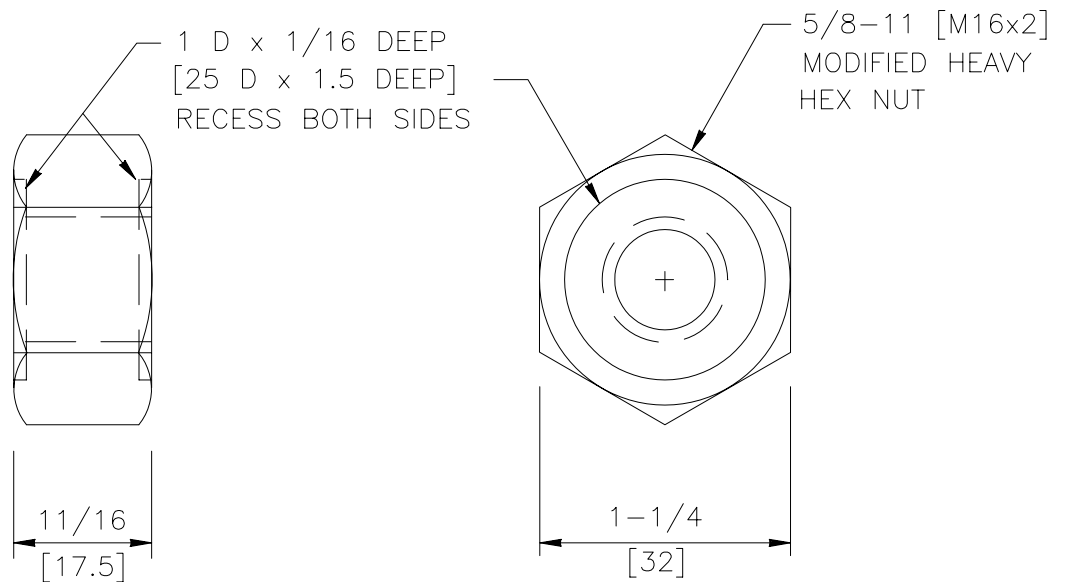

1976

GUARDRAIL BOLT AND RECESSED NUT

FBB01-05

SHEET NO.

DATE:

1 of 2

6/30/2005

SPECIFICATIONS

The geometry and material specifications for this oval shoulder button-headed bolt and hex nut are found in AASHTO M 180. The bolt shall have 5/8-11 [M16x2] threads as defined in ANSI B1.1 [ANSI B1.13M] for Class 2A [6g] tolerances. Bolt material shall conform to ASTM A307 Grade A [ASTM F 568M Class 4.6], with a tensile strength of 60 ksi [400 MPa] and yield strength of 36 ksi [240 MPa]. Material for corrosion-resistant bolts shall conform to ASTM A325 Type 3 [ASTM F 568M Class 8.8.3], with tensile strength of 120 ksi [830 MPa] and yield strength of 92 ksi [660 MPa]. This bolt material has corrosion resistance comparable to ASTM A588 steels. Metric zinc-coated bolt heads shall be marked as specified in ASTM F 568 Section 9 with the symbol "4.6."

Nuts shall have ANSI B1.1 Class 2B [ANSI B1.13M Class 6h] 5/8-11 [M16x2] threads. The geometry of the nuts, with the exception of the recess shown in the drawing, shall conform to ANSI B18.2.2 [ANSI B18.2.4.1M Style 1] for zinc-coated hex nuts (shown in drawing) and ANSI B18.2.2 [ANSI B18.2.4.6M] for heavy hex corrosion-resistant nuts (not shown in drawing). Material for zinc-coated nuts shall conform to the requirements of AASHTO M 291 (ASTM A 563) Grade A [AASHTO M 291M (ASTM A 563M) Class 5], and material for corrosion-resistant nuts shall conform to the requirements of AASHTO M 291 (ASTM A 563) Grade C3 [AASHTO M 291M (ASTM A 563M) Class 8S3].

When zinc-coated bolts and nuts are required, the coating shall conform to either AASHTO M 232 (ASTM A 153/A 153M) for Class C or AASHTO M 298 (ASTM B 695) for Class 50. Zinc-coated nuts shall be tapped over-size as specified in AASHTO M 291 (ASTM A 563) [AASHTO M 291M (ASTM A 563M)], except that a diametrical allowance of 0.020 inch [0.510 mm] shall be used instead of 0.016 inches [0.420 mm].

Designator	Stress Area of Threaded Bolt Shank (in ² [mm ²])	Min. Bolt Tensile Strength (kips [kN])
FBB01-05	0.226 [157.0]	13.6 [62.8]

Dimensional tolerances not shown or implied are intended to be those consistent with the proper functioning of the part, including its appearance and accepted manufacturing practices.

INTENDED USE

These bolts and nuts are used in numerous guardrail and median barrier designs.

GUARDRAIL BOLT AND RECESSED NUT

FBB01-05

SHEET NO.

DATE

2 of 2

6/30/2005