

NOTES

GENERAL: For additional rail details, see **SCD MGS-1.1**. For barrier guardrail details see **SCD MGS-2.1**. See Sheet 2 for Sections (single sided BTA shown).

APPLICATION: Use Type 1 MGS Bridge Terminal Assembly to connect guardrail runs to bridges having deflector Parapet Type Bridge Railing (see Structural Engineering's **SCD SBR-1-13, BR-1-13, TST-1-99**) and for runs to the approach ends of Concrete Barrier (see **SCD RM-4.6**).

This BTA should also be used to connect guardrail runs to bridges with Twin Steel Tube Railing (see Structural Engineering's **SCD TST-1-99**). Connection details for the TST are shown on Page 2.

THRIE BEAM: An 18'-9" Section of Thrie beam may be substituted for one of the 12'-6" panels and the 6'-3" section as shown. When attaching this BTA to preexisting walls/parapets, a longer thrie beam panel or a short (approx. 1'-6") panel is permitted to reach the available bolt hole locations.

THRIE BEAM TRANSITION: Assymetrical W-Beam to Thrie Beam transition panel shall be 10 gauge.

POSTS: Use standard steel or 6"x8"x72" wood posts per **SCD MGS-2.1** for Posts No. 7-13. Posts may be set in drilled holes or driven to grade. Posts No. 1-6 are 6'-6" W6x9 steel or 6"x8"x84" wood. Use the same post material throughout the length of the transition unless otherwise specified in the plans or permitted by the Engineer (steel posts shown in this drawing). Wood posts shall be fabricated and pressure-treated for approved species as per CMS 710.12. Bore bolt holes and, if required, trim the tops of posts after the posts are set.

BLOCKOUTS: Use 6"x12"x19" (or 6"x12"x22") wood blockouts at Posts No. 1-12. The standard MGS 6"x12"x14" blockout is used at Post 13. Approved Alternate Blockouts can be found on the Office of Roadway Engineering's website. Steel Blockouts are not permitted.

FLARED GUARDRAIL: The MGS guardrail should be tangential within 25 ft. of the BTA.

CURB: Type 4A, 4B, or 4C Curb per **SCD BP-5.1** is required under the thrie-beam portion of this transition when connecting to concrete barrier or parapet, but shall not extend past Post No. 11. Curb is NOT required when connecting to TST Bridge Rail.

**** Where curb must extend upstream of Post No. 11 for drainage purposes, an extra 12'-6" panel of 12 gauge w-beam must be nested prior to the transition (upstream of Post No. 13). This added component shall be included as incidental to the cost of the BTA.**

PAYMENT: Item 606 - MGS Bridge Terminal Assembly, Type 1, Each or Item 606 - MGS Bridge Terminal Assembly, Type 1, Barrier Design, Each, includes the cost of all components including additional and different size of posts and blockouts, nested Thrie-Beam, transition and connector sections, Bearing Plate, bolts, washers, nuts, and other hardware.

Curb is paid separately under **Item 609 - Curb, Type 4...**, in feet.

* Place the first post of the MGS 3'-1/2" past the BTA, then every 6'-3" thereafter to keep posts offset from the rail splices. A minimum of 12'-6" of MGS Guardrail should be placed between the BTA and end anchor.

THIS DRAWING REPLACES MGS-3.1 DATED 7-21-2017

SCD NUMBER	STATE OF OHIO DEPARTMENT OF TRANSPORTATION ADMINISTRATOR	REVISION DATE
MGS-3.1	David L. Holstein	1-19-2018
OFFICE OF ROADWAY ENGINEERING	STATE ENGINEER	
MIDWEST GUARDRAIL SYSTEM	D. Fisher	
MGS BRIDGE TERMINAL ASSEMBLY, TYPE 1		

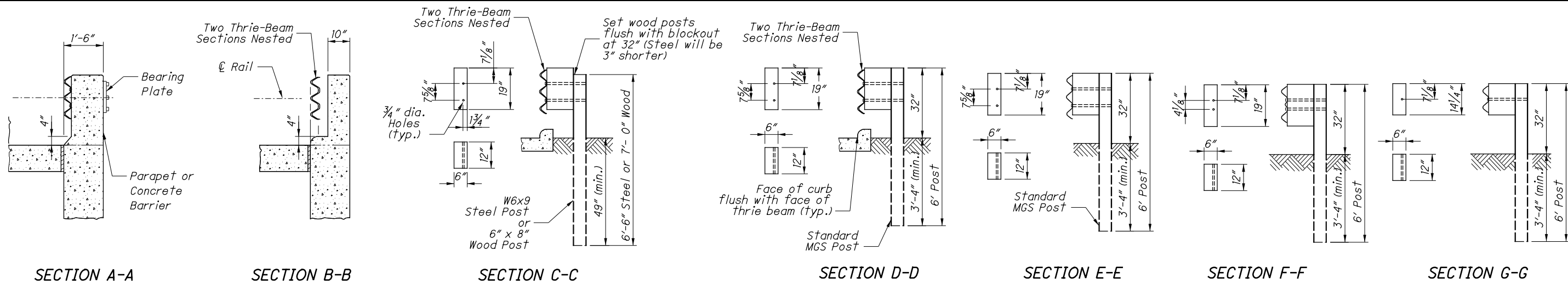

SECTION A-A

SECTION B-B

SECTION C-C

SECTION D-D

SECTION E-E

SECTION F-F

SECTION G-G

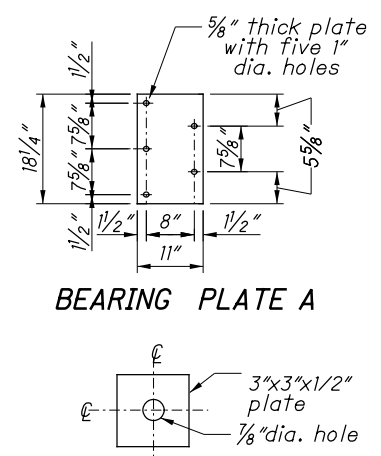

BEARING PLATE A

BEARING PLATE B

AASHTO/AGC/ARTBA
Standardized Hardware
Guide part FW09

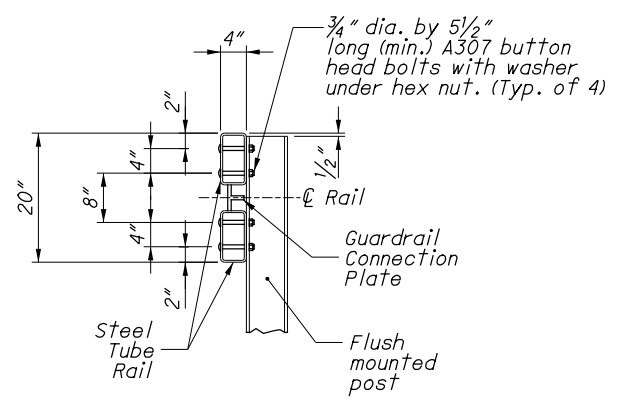

SECTION H-H
Section through Tubing at Post

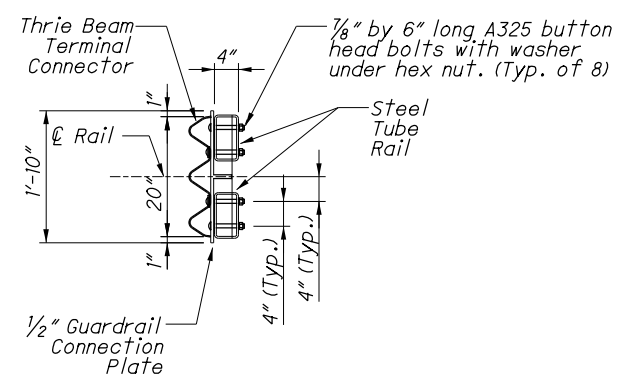

SECTION J-J
Section through Tubing at Terminal Connector

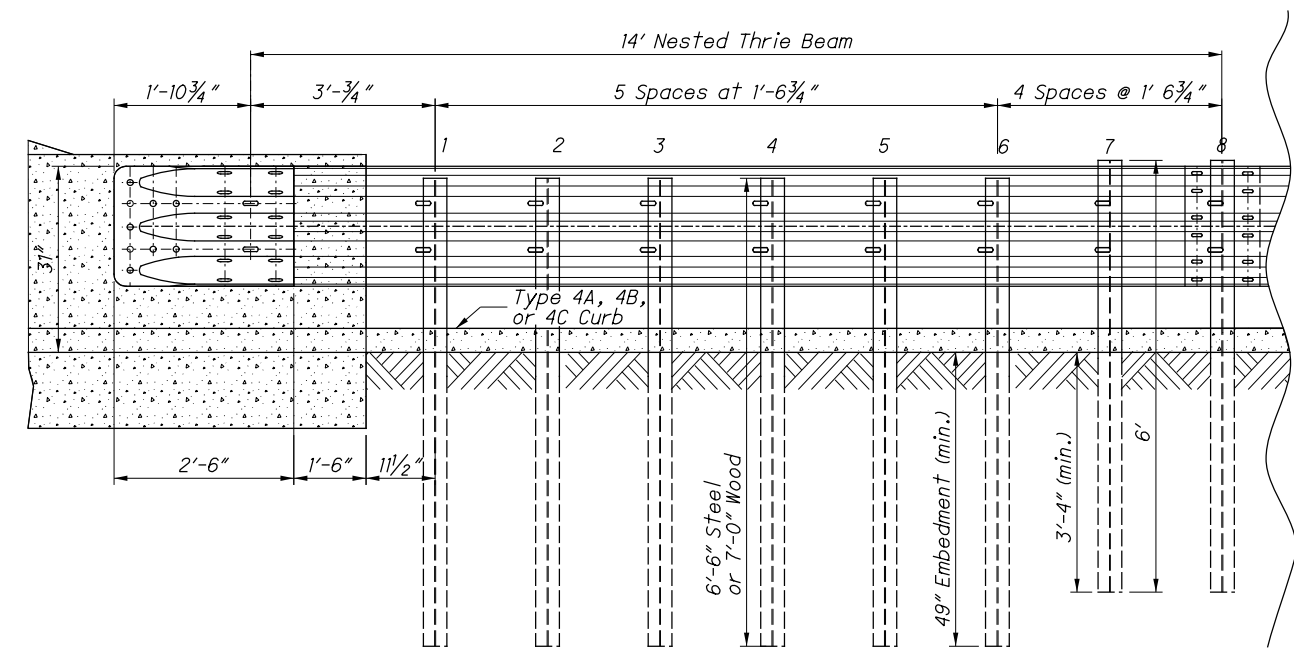

CONNECTION DETAILS TO CONNECT
THRIE BEAM TO PREEXISTING WALLS/PARAPETS

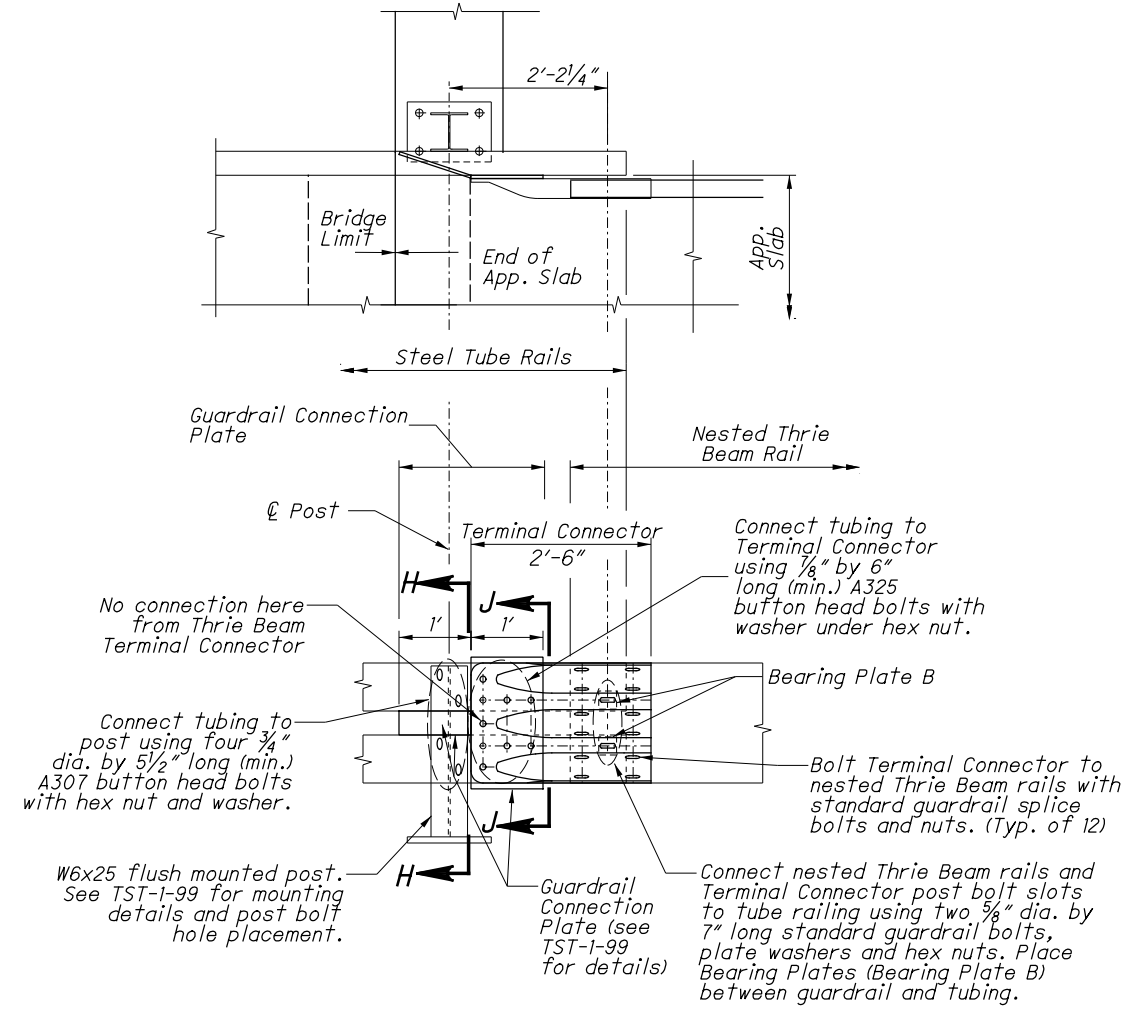

CONNECTION DETAILS TO CONNECT
WITH TWIN STEEL TUBE BRIDGE RAILING
(SEE SCD TST-1-99)

SCD NUMBER	STATE OF OHIO DEPARTMENT OF TRANSPORTATION ADMINISTRATOR	REVISION DATE
MGS-3.1	David L. Holstein	1-19-2018
OFFICE OF ROADWAY ENGINEERING	D. Fisher	
MGS BRIDGE TERMINAL ASSEMBLY, TYPE 1		
MIDWEST GUARDRAIL SYSTEM		
THIS DRAWING REPLACES MGS-3.1 DATED 7-21-2017		
STANDARD ROADWAY CONSTRUCTION DRAWING		