

DESIGNER INFORMATION

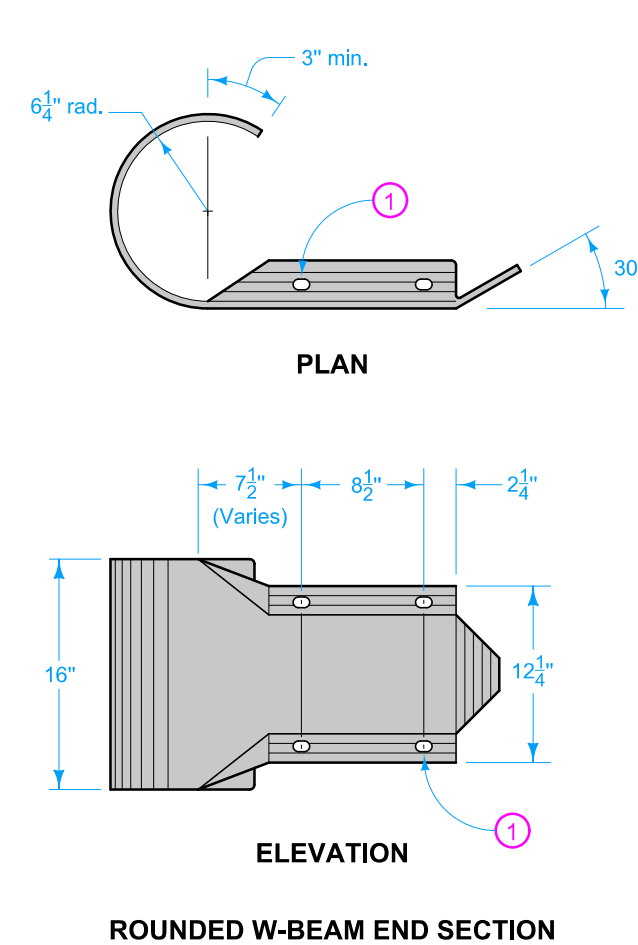
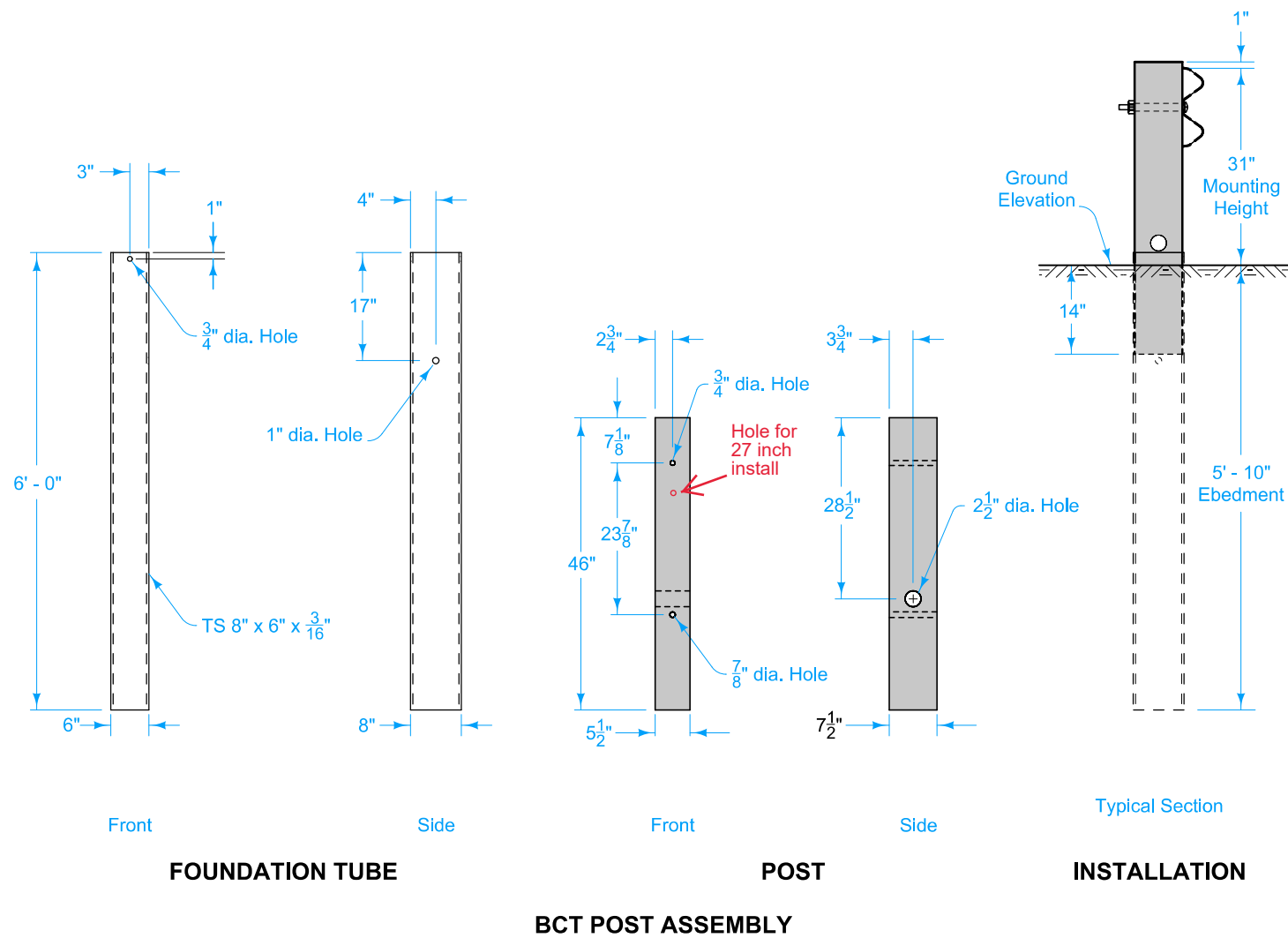
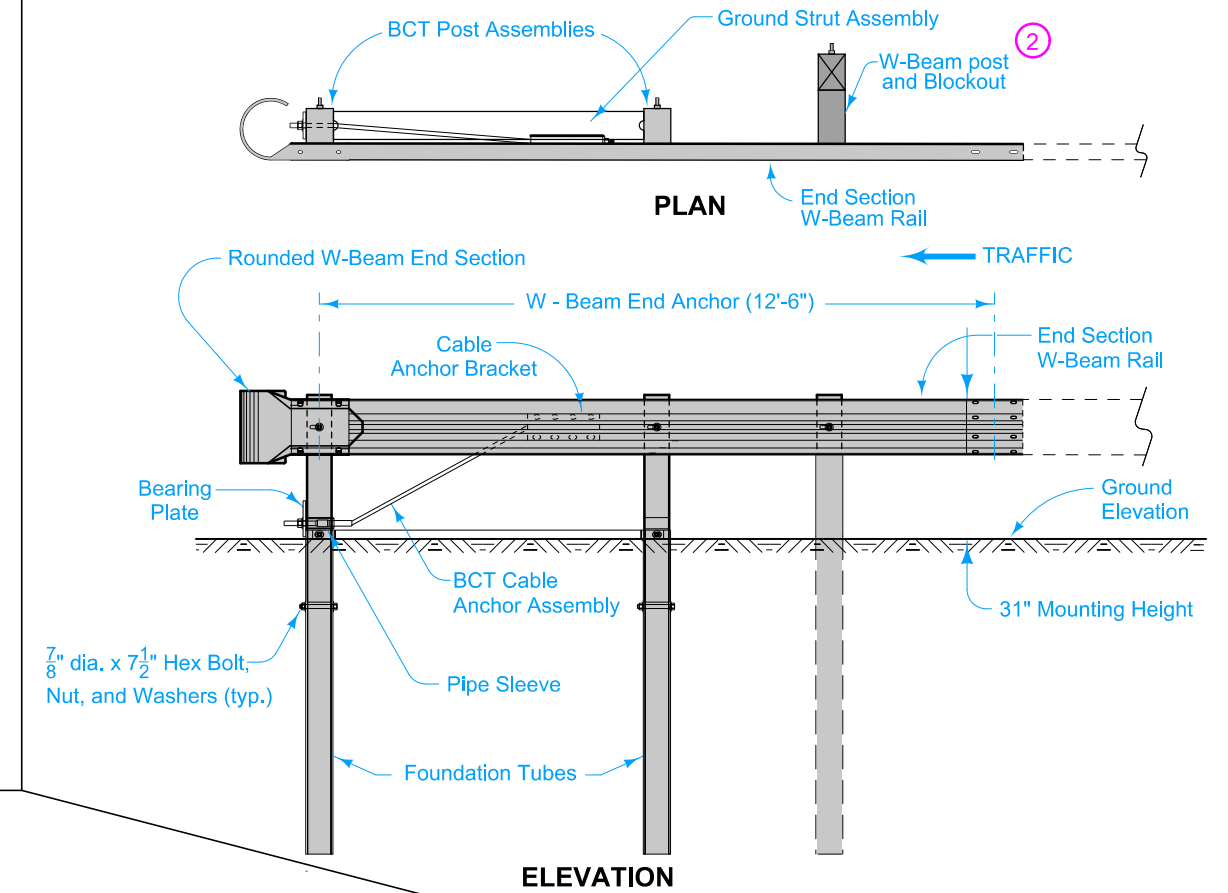
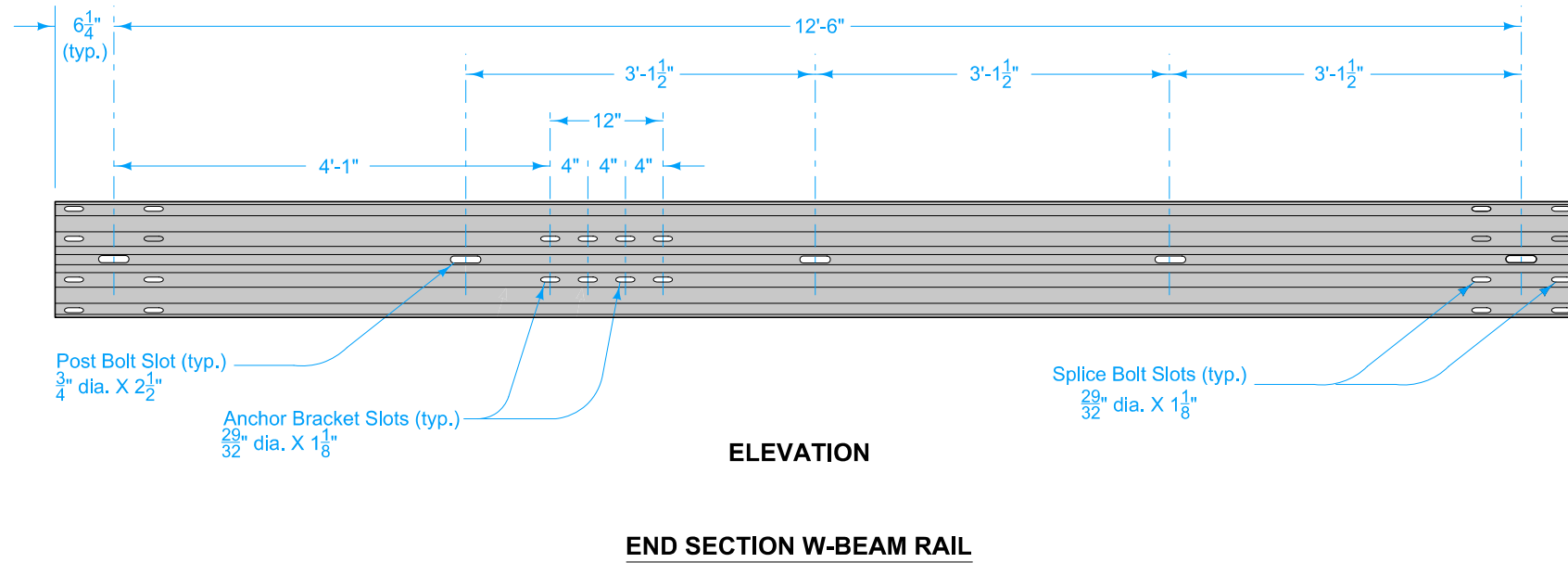

- ① 29/32" x 1 1/8" slots (29/32" x 3" slots acceptable).
- ② Refer to BA-200.

Possible Contract Item:
Steel Beam Guardrail End Anchor, W-Beam

- Materials included in the Contract Item:
- (1) 12'-6" End Section W-Beam Rail
 - (2) Foundation Tube Assemblies
 - (2) BCT Wood Posts
 - (1) Rounded W-Beam End Section
 - (1) Cable Anchor Bracket
 - (1) BCT Cable Anchor Assembly
 - (1) Ground Strut Assembly
 - (1) Pipe Sleeve
 - (1) Bearing Plate
 - (1) W-Beam Post (wood or steel - match remainder of installation)
 - (1) W-Beam Blockout
 - Approved bolts, nuts, and washers

IOWA DOT	REVISION	
	2	10-15-19
STANDARD ROAD PLAN		BA-203
REVISIONS: New logo.		SHEET 1 of 1
 APPROVED BY DESIGN METHODS ENGINEER		

STEEL BEAM GUARDRAIL W-BEAM END ANCHOR