

Midwest Guardrail System for Standard and Special Applications

Ronald K. Faller, Karla A. Polivka, Beau D. Kuipers, Robert W. Bielenberg, John D. Reid, John R. Rohde, and Dean L. Sicking

Development, testing, and evaluation of the Midwest Guardrail System were continued from the original research started in 2000. This new strong-post W-beam guardrail system provides increased safety for impacts with higher-center-of-mass vehicles. Additional design variations of the new system included stiffened versions using reduced (half and quarter) post spacings as well as a standard guardrail design configured with a concrete curb 152 mm (6 in.) high. All full-scale vehicle crash tests were successfully performed in accordance with the Test Level 3 requirements specified in *NCHRP Report 350: Recommended Procedures for the Safety Performance Evaluation of Highway Features*. The research study also included dynamic bogie testing on steel posts placed at various embedment depths and computer simulation modeling with BARRIER VII to analyze and predict dynamic guardrail performance. Recommendations for the placement of the original Midwest Guardrail System as well as its stiffened variations were also made.

For more than 50 years, strong-post W-beam guardrail systems have been placed along the nation's highways and roadways to prevent errant motorists from striking hazards located beyond the roadway edge. In general, these systems have consisted of a single 2.66-mm-thick (12-gauge) W-beam rail supported by steel or wood posts spaced 1,905 mm (75 in.) on center. Although several rail spacer (blockout) variations have existed throughout the United States, one common W-beam guardrail system incorporated a wood blockout 203 mm (8 in.) deep in conjunction with 530-mm (20⁷/₈-in.) and 686-mm (27-in.) center and top rail mounting heights, respectively. This guardrail design is the most common barrier system in use today and has had a good safety performance for many years.

Although these original W-beam guardrail designs were successfully developed to contain and safely redirect full-size sedans and later small cars, one research study indicated a performance weakness for standard guardrail designs. In 1983, the Texas Transportation Institute (TTI) conducted a study to determine the performance limits of the G4(1S), modified G4(2W), and modified G4(1S) longitudinal barrier systems (1). For this effort, seven crash tests were performed into strong-post W-beam guardrail systems by using several vehicle types, including a sedan, small cars, pickup trucks, and a van. Several important conclusions could be drawn from these tests. First, a standard wood post W-beam guardrail system installed to a 762-mm (30-in.) top mounting height could safely contain and redirect small cars with only limited wheel snag on the wood posts.

Midwest Roadside Safety Facility, University of Nebraska–Lincoln, 527 Nebraska Hall, Lincoln, NE 68588-0529.

Transportation Research Record: Journal of the Transportation Research Board, No. 1890, TRB, National Research Council, Washington, D.C., 2004, pp. 19–33.

The standard steel post, steel blockout W-beam guardrail system was evaluated by using small and ½-ton full-size pickup trucks and a van. Although this W-beam guardrail system was shown to be capable of safely containing and redirecting small and full-size pickup trucks, testing revealed a tendency for the front wheel to severely snag on the posts. The wheel snag resulted in heavy damage to the front quarter and wheel assembly regions and a potential for a moderate vehicle roll angle during exit from the barrier. Finally, testing also showed that the steel post W-beam guardrail system was incapable of safely redirecting a full-size van as the vehicle rolled over after exiting the barrier.

In 1993, *NCHRP Report 350: Recommended Procedures for the Safety Performance Evaluation of Highway Features* (2) was published. It provided new and revised crash testing guidelines and introduced the ¾-ton pickup truck as a replacement for the full-size passenger sedan vehicle used previously. After the implementation of these new impact safety standards, several crash testing studies were conducted to determine whether existing 686-mm (27-in.) high strong steel and wood post W-beam guardrail systems would meet the new NCHRP report requirements (3–5). The results from these studies revealed differing levels of safety performance. The wood post, wood blockout guardrail system adequately contained and redirected the pickup truck, while the steel post with steel and wood blockout guardrail systems both resulted in vehicle rollover. During the same period, metrication of roadside safety hardware occurred and resulted in a repositioning of the W-beam rail center height to 550 mm (21.65 in.). Several research studies were performed to investigate the safety performance of 706-mm (27.78-in.) high strong-post W-beam guardrail systems subjected to ¾-ton pickup truck impacts at the target conditions of 100 km/h (62.14 mph) and 25° (4, 6–10). The studies included additional testing on steel post, wood blockout W-beam guardrail systems that resulted in either an acceptable or an unsatisfactory safety performance. Although most of the crash tests resulted in satisfactory barrier performance, there were indications that these W-beam guardrail systems may not have sufficient reserve capacity to safely contain and redirect higher-center-of-mass vehicles during high-speed and high-angle collisions. Therefore, even though several strong-post W-beam guardrail designs meet the *NCHRP Report 350* safety standards, there is significant potential to improve the barrier's safety performance during impacts with high-center-of-mass vehicles.

In 2000, the Midwest States' Regional Pooled Fund Program sponsored a research study at the Midwest Roadside Safety Facility (MwRSF) to develop a new guardrail system that would improve barrier performance for higher-center-of-mass vehicles, provide reasonable barrier height tolerances, and reduce the potential for W-beam rupture (11–13). Relying heavily on LS-DYNA modeling (14),

researchers investigated existing W-beam systems and made changes to those designs to improve barrier performance for higher-center-of-mass vehicles while maintaining acceptable performance for small cars. These changes included a new W-beam rail top mounting height of 787 mm (31 in.), a reduced guardrail post embedment depth, an increased blockout depth from 203 mm (8 in.) to 305 mm (12 in.), and a repositioning of the guardrail splice from a post to a midspan location. The early development efforts demonstrated that the new barrier system with an 813-mm (31-in.) mounting height could perform well during small car impacts. Although the barrier did pass a full-scale crash test with a $\frac{3}{4}$ -ton pickup truck, the barrier's anchor was pulled completely out of the ground. Furthermore, this research did not examine alternative guardrail installation problems, such as placement adjacent to curb or reduction of post spacing to limit lateral deflections. Hence, much additional research was necessary before the Midwest Guardrail System could be widely implemented.

As previously mentioned, longitudinal barrier systems are used for shielding roadside hazards. However, limited space may be available between the edge of the traveled way and the front of the hazard—for example, when concrete bridge piers are found near the roadway shoulder. In these instances, roadway designers may need to use stiffened variations of the standard W-beam guardrail system to reduce dynamic deflections and allow for a closer placement of the barrier to the hazard. In the past, computer simulation studies and full-scale crash testing programs have been used to better understand guardrail stiffening techniques, such as guardrail nesting and reduced post spacing, as well as to formulate guardrail placement guidelines (15–18; 19, Chapter 5, Section 5.5.2). Therefore, before the Midwest Guardrail System can be widely implemented in the field, it will be necessary for researchers and roadway designers to better understand the dynamic performance of this new barrier system for both the stiffened and the unstiffened configurations. Once the dynamic performances of typical guardrail stiffening techniques for the Midwest Guardrail System are fully understood, minimum design recommendations for the placement of the various guardrail systems with respect to hazards can be determined.

Curbs are often used along the roadway edge to provide drainage control, roadway edge delineation and support, right-of-way reduction, and sidewalk separation, and to perform several other functions. Since hazards are often found along roadways with curbs, W-beam guardrail systems are frequently installed over curbs. In recent years, two research studies were conducted to test and evaluate standard W-beam guardrail systems installed over curbs 102 mm (4 in.) high according to the *NCHRP Report 350* guidelines (20–22). In 2000, TTI researchers performed a study that showed that the G4(2W) guardrail system, installed over an asphaltic curb 102 mm (4 in.) high, would adequately contain and redirect $\frac{3}{4}$ -ton pickup trucks. However, in a separate study, MwRSF engineers tested and evaluated the modified G4(1S) guardrail system installed over a concrete curb and encountered unsatisfactory results. The W-beam guardrail ruptured at a splice location, allowing the vehicle to penetrate behind the system. Several alternatives were considered, including guardrail nesting, using a single 3.42-mm (10-gauge) W-beam rail, and relocating the rail splice away from a post location. Researchers modified the guardrail system to use two nested 2.66-mm (12-gauge) W-beam rails. Pickup truck testing on this nested, modified G4(1S) guardrail system produced satisfactory results. However, the vehicle was redirected into the air and landed on the barrier downstream. Both guardrail-to-curb combinations were constructed with the toe of the curb either at or within 25 mm (1 in.) of the rail face, because past research has shown that curbs

placed in front of W-beam guardrails can lead to the vehicle's climbing and vaulting over the barriers (21). Although these two W-beam guardrail systems installed over curbs met the *NCHRP Report 350* requirements, it is generally believed that W-beam guardrail systems with curbs higher than 102 mm (4 in.) would not be capable of meeting current safety standards. Placement of the 102-mm (4-in.) high curbs farther away from the front face of the existing W-beam barrier system also may not be capable of meeting pickup truck crash testing requirements. Since the Midwest Guardrail System may be more accommodating to the higher-center-of-mass vehicles, use of taller curbs in combination with the W-beam guardrail system and consideration of their placement farther away from the front of the rail face may be feasible. Placement of curbs at a greater distance in front of the guardrail face reduces the propensity for snowplows to gouge or damage the W-beam rail sections.

RESEARCH OBJECTIVE

The objectives of the research project were to (a) continue the development of the Midwest Guardrail System to provide increased safety for higher-center-of-mass vehicles, provide reasonable barrier height tolerances, and reduce the potential for W-beam rupture; (b) evaluate guardrail stiffening and determine appropriate guardrail placement guidelines for shielding rigid hazards using full-, half-, and quarter-post spacing designs; and (c) develop a guardrail-to-curb barrier combination that provides increased hydraulic capacity and placement farther in front of the rail face to reduce the frequency of snowplow damage to guardrails. All development and testing of the Midwest Guardrail System were conducted in accordance with the Test Level 3 (TL-3) safety performance criteria set forth in *NCHRP Report 350*. The study was performed by MwRSF in cooperation with the Midwest States' Regional Pooled Fund Program.

TEST REQUIREMENTS AND EVALUATION CRITERIA

Longitudinal barriers, such as W-beam guardrail systems, must satisfy the requirements set forth in *NCHRP Report 350* to be accepted for use on new construction projects or when out-of-date designs must be replaced. According to TL-3 of *NCHRP Report 350*, guardrail systems must be subjected to two full-scale vehicle crash tests: (a) a 2,000-kg (4,409-lb) pickup truck striking at a speed of 100 km/h (62.14 mph) and at an angle of 25°; and (b) an 820-kg (1,808-lb) small car striking at a speed of 100 km/h (62.14 mph) and at an angle of 20°. Finally, the full-scale vehicle crash tests were conducted and reported in accordance with the *NCHRP Report 350* procedures.

In 2001, a small car crash testing and evaluation program was successfully completed on an 813-mm (32-in.) tall version of the Midwest Guardrail System that used the standard post spacing (11, 12). In this paper, only research results for the pickup truck impact condition provided in *NCHRP Report 350* and for the standard and reduced post spacing design variations as well as for the guardrail-to-curb barrier combination are shown. Since the small car test results were satisfactory for the full post spacing guardrail design, additional small car testing was deemed unnecessary for the reduced post spacing designs. Prior research has shown successful safety performance for small cars striking guardrail-to-curb barrier combinations using a 152-mm (6-in.) high asphalt dike (23). When struck by a small car, this barrier system, like other strong-post W-beam barriers, remained essentially rigid with only modest deflection. In

addition, the small car tests indicated no significant potential for occupant risks arising from vehicle pocketing or severe wheel snagging on the guardrail posts and no potential for rail rupture or vehicular instabilities due to vaulting or climbing the rail (1, 24, 25). Therefore, the 820-kg (1,808-lb) small car test was also deemed unnecessary for the evaluation of the guardrail-to-curb barrier combination of the Midwest Guardrail System.

DESIGN CONSIDERATIONS AND MODIFICATIONS

During the early development of the Midwest Guardrail System, LS-DYNA computer simulation modeling was used to investigate how both guardrail-post connection strength and post-soil force affect barrier performance during impacts with higher-center-of-mass vehicles (11). Two important conclusions were drawn from that investigation. First, researchers showed that as the guardrail-post connection strength increased from a typical strength to a very strong attachment, there was a reduction in the W-beam guardrail system's ability to capture light trucks. Second, the simulation results indicated an increased propensity for the light trucks to climb and vault over the barrier system when the guardrail posts were placed in a simulated strong soil versus a weaker, softer soil.

As a result of these findings, the first three crash tests were performed on a barrier prototype that incorporated an increased length of the post bolt slot equal to 102 mm (4 in.). The increased slot length was used to reduce the guardrail-post attachment force, thus decreasing the potential for the W-beam rail to be pulled down during post rotation. The first small car crash test (Test NPG-1) resulted in acceptable performance of an original guardrail design that used an increased slot length (11, 12). A subsequent pickup truck crash test also showed that the rail would release from the posts in an acceptable manner throughout the impact region. However, the testing also indicated a propensity for the rail to release prematurely from the posts near the upstream end of the barrier installation. As a result, the post bolt slot was reduced back to the standard 64-mm (2½-in.) length.

Guardrail posts are an integral part of the design of semirigid barriers. Post performance greatly influences the guardrail system's ability to contain and redirect the striking vehicle safely and allows for the dissipation of a portion of the vehicle's kinetic energy through rotation of the post in the soil. Since post-soil forces are approximately proportional to the square of the post embedment depth, the appropriate post length, post embedment depth, and rail mounting height are all critical elements for the new guardrail design. These elements are even more important since the preliminary numerical analysis showed that higher post-soil forces may degrade guardrail performance.

DYNAMIC POST TESTING

Dynamic testing of steel posts placed in soil was conducted to evaluate alternative embedment depths as well as to determine the associated force-deflection behaviors. The steel posts were embedded in soil material conforming to AASHTO M147-65 Gradation B specifications (NCHRP Report 350 strong soil). The posts used in the Midwest Guardrail System consisted of W152 × 13.4 (W6 × 9) steel sections. However, the dynamic bogie testing performed for this study utilized W152 × 23.8 (W6 × 16) sections for the alternative embedment depths to isolate soil failure with only minimal post yielding. Since the W152 × 23.8 (W6 × 16) post has a flange width and

overall depth similar to that of the W152 × 13.4 (W6 × 9) post, it was believed that the posts would exhibit similar post-soil behavior. A 1,014-kg (2,237-lb) rigid-frame bogie vehicle was used to strike the steel guardrail posts at a target speed of 32.2 km/h (20 mph). An impact head, fabricated from a concrete-filled steel pipe 203 mm (8 in.) in diameter and used to strike the posts, was mounted to the front end of the bogie vehicle 632 mm (24⅞ in.) above the ground surface. Additional details concerning the bogie vehicle and the test setup are provided elsewhere (13).

Ten dynamic bogie tests were performed on the embedded steel posts. Actual impact conditions, post embedment depths, and results are provided in Table 1. All steel posts were struck perpendicular to the front face of the posts or about the post's strong axis of bending, as shown in Figure 1(a). Typical post and soil deformations following two bogie tests are provided in Figure 1(b). Typical force-deflection curves for the steel posts embedded 1,016 mm (40 in.) into the soil are provided in Figure 1(c). Failure of the posts was dependent on embedment depth. For post embedment depths of 1,016 mm (40 in.) or greater, soil failure was observed with occasions of slight yielding within the post. For post embedment depths of 940 mm (37 in.) or less, the posts were pulled out of the ground after rotating in the soil for some distance. In addition, there were measurable differences in the impact forces observed for the two modes of failure. As a result of the differing impact forces, the amount of energy dissipated also varied. Posts that failed by rotating in the soil dissipated more energy than posts that initially rotated but eventually pulled out of the ground. Additional discussion of the post testing results is provided in the MwRSF research report (13).

On the basis of the results of the dynamic post testing program, researchers determined that the 1,016-mm (40-in.) embedment depth was a reasonable choice for use in the Midwest Guardrail System. This embedment depth, combined with a 1,829-mm (6-ft) long post and a 787-mm (31-in.) rail top mounting height, provides acceptable post-soil forces and energy dissipation.

One purpose of analyzing the force-deflection curve and energy dissipated during a post test is to quantify post-soil interaction parameters. These parameters are of great interest to those studying vehicular impacts into longitudinal barrier systems, such as the Midwest Guardrail System, through the use of dynamic computer simulation modeling. Relevant results from this study for use in these analytical investigations are the estimated initial post stiffness and the estimated average force for the first 381 to 597 mm (15 to 23.5 in.) of dynamic displacement after the initial slope of the impact force. Over this distance, the guardrail post is typically separated from the W-beam rail, on the basis of observations from full-scale crash tests. Therefore, calculated parameters for estimated average force and estimated initial stiffness are also provided in Table 1.

MIDWEST GUARDRAIL SYSTEM DESIGN DETAILS

Design A: Standard 1,905-mm Post Spacing

The first test installation (Design A) consisted of 55.25 m (181 ft 3 in.) of standard 2.66-mm-thick (12-gauge) W-beam guardrail supported by steel posts, as shown in Figure 2. Anchorage systems similar to those used on tangent guardrail terminals were used on both the upstream and downstream ends of the guardrail system. A photograph of the test installation is shown in Figure 2.

The entire system was constructed with 29 guardrail posts. Posts 3 through 27 were galvanized ASTM A36 steel W152 × 13.4 (W6 × 9)

TABLE 1 Steel Post Bogie Impact Test Matrix and Results

Bogie Test No.	Impact Speed (m/s)	Embedment Depth (mm)	Initial Peak Force		Estimated Average Force ¹		Estimated Initial Stiffness ² (kN/mm)	Total Energy		Failure Mode
			Deflection (cm)	Force (kN)	Measured @ 381 mm Dynamic Deflection (kN)	Measured @ 597 mm Dynamic Deflection (kN)		Deflection (cm)	Energy (kJ)	
NPGB-1 ³	8.94	1092	6.12	47.91	28.98	30.63	0.783	104.53	29.82	Post Rotation, Slight Yielding
NPGB-3 ³	8.94	1092	5.29	43.00	25.57	26.35	0.813	124.17	28.45	Post Rotation, Slight Yielding
Average	8.9	1092	5.7	45.5	27.3	28.5	0.798	114.4	29.1	
NPGB-2 ³	9.39	1016	5.56	36.76	27.27	29.93	0.661	115.29	29.15	Post Rotation
NPGB-4	8.94	1016	5.56	52.83	28.73	29.30	0.950	109.23	29.14	Post Rotation
NPGB-9	9.28	1016	5.48	58.04	28.14	28.31	1.059	122.15	29.16	Post Rotation, Slight Yielding
NPGB-10	9.61	1016	5.97	62.89	29.99	31.47	1.053	118.56	31.78	Post Rotation, Slight Yielding
Average	9.3	1016	5.6	52.6	28.5	29.8	0.931	116.3	29.8	
NPGB-5	8.94	940	7.24	52.39	24.85	26.95	0.724	136.50	27.37	Post Pulled Out of Ground
NPGB-7	8.81	940	4.93	57.23	23.13	24.04	1.161	132.63	22.50	Post Pulled Out of Ground
NPGB-8	9.25	940	7.19	72.34	26.38	27.01	1.006	116.41	24.83	Post Pulled Out of Ground
Average	9.0	940	6.5	60.7	24.8	26.0	0.964	128.5	24.9	
NPGB-6	9.16	864	4.56	55.44	24.63	24.79	1.216	134.01	24.20	Post Pulled Out of Ground

NOTE: 1 in. = 25.4 mm.

¹ Determined after initial slope.

² Determined using initial peak force and deflection.

³ Results may have been affected by wet soil conditions.

sections measuring 1,829 mm (6 ft) long. Posts 1, 2, 28, and 29 were timber and were 140 mm wide × 190 mm deep × 1,080 mm long (5½ × 7½ × 42½ in.) and were placed in steel foundation tubes 1,829 mm (6 ft) long. The timber posts and foundation tubes were part of anchor systems designed to replicate the capacity of a tangent guardrail terminal.

Posts 1 through 29 were spaced 1,905 mm (75 in.) on center with a soil embedment depth of 1,019 mm (40 in.), as shown in Figure 2. The posts were placed in a compacted coarse crushed limestone material that met Grading B of AASHTO M147-65 (1990) as found in *NCHRP Report 350*. For Posts 3 through 27, wood spacer block-outs 152 mm wide × 305 mm deep × 356 mm long (6 × 12 × 14 in.) were used to block the rail away from the front face of the steel posts.

Standard 2.66-mm-thick (12-gauge) W-beam rails with additional post bolt slots at half-post spacing intervals were placed between Posts 1 and 29, as shown in Figure 2. The nominal top mounting height of the W-beam rail was 787 mm (31 in.), with a 632-mm (24⅞-in.) center height. The rail splices have been moved to the center of the span location, as shown in Figure 2. All lap-splice connections between the rail sections were configured to reduce vehicle snag at the splice during the crash test.

Design B: Reduced 476-mm Post Spacing

The second test installation (Design B) was identical to the first system (Design A) except that the original guardrail system was stiffened through the use of a reduced post spacing. Posts 9 through 11 and 51 through 53 were spaced 952.5 mm (37½ in.) on center, while Posts 11 through 51 were spaced 476.25 mm (18¾ in.) on center. The standard 2.66-mm-thick (12-gauge) W-beam rails located between

Posts 9 and 53 were modified to include additional post bolt slots at half- and quarter-post spacing intervals, as shown in Figure 3(a).

Design C: Standard 1,905-mm Post Spacing with 152-mm Type B Curb

The third test installation (Design C) was identical to the first system (Design A) except that the guardrail system was installed over a 152-mm (6-in.) tall AASHTO Type B concrete curb. A concrete curb 152 mm (6 in.) high versus a curb 102 mm (4 in.) high was selected for testing since increased hydraulic drainage is often required at the roadway edge, and the taller curb is believed to provide a worst-case impact scenario for the guardrail-to-curb barrier combination. Therefore, if the test results are satisfactory, shorter curb heights would also be acceptable and would not require additional testing. The curb located beneath the W-beam guardrail was 19.05 m (62 ft 6 in.) long, spanning between Posts 10 and 20. The curb was constructed such that the center of the curb face was placed 152 mm (6 in.) in front of the front face of the guardrail, as shown in Figure 3(b). The top mounting height of the guardrail remained at 787 mm (31 in.), measured from the gutter line to the top of the W-beam rail.

FULL-SCALE VEHICLE CRASH TESTING

Crash Test NPG-4—Design A

For Test NPG-4, a 1,986-kg (4,378-lb) pickup truck struck the Midwest Guardrail System with standard post spacing (Design A) at a speed of 98.1 km/h (61.0 mph) and an angle of 25.6°. Initial

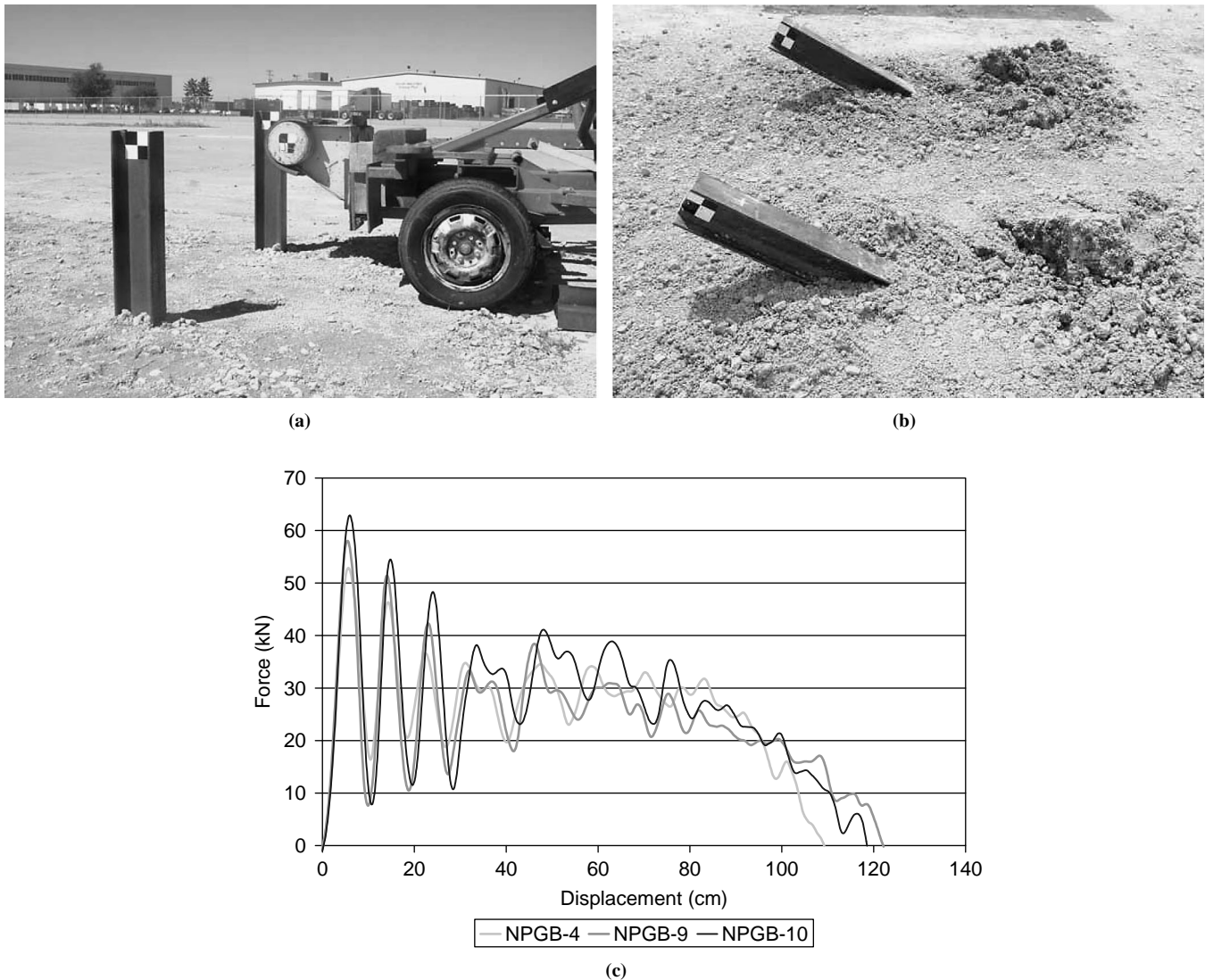

FIGURE 1 (a) Typical posts installed for bogie testing; (b) typical post deformation in soil; (c) force–displacement curves for 1,016-mm embedment depth (1 in. = 25.4 mm).

impact occurred 4,839 mm (190½ in.) upstream from the centerline of the splice between Posts 14 and 15, as shown in Figure 4. At 0.396 s after impact, the vehicle became parallel to the guardrail with a resultant velocity of 61.2 km/h (38.0 mph). The vehicle was safely redirected in a stable manner with very little roll or pitch. At 0.597 s, the vehicle exited the guardrail at a trajectory angle of 19.3° and a resultant velocity of 55.1 km/h (34.2 mph). Exterior vehicle damage was minimal, consisting of minor right-front corner deformations, and there was no observable occupant compartment deformation. Damage to the barrier was moderate, consisting mostly of deformed W-beam and guardrail posts, contact marks on a guardrail section, and disengaged wooden blockouts. Maximum dynamic barrier deflection was 1,094 mm (43 in.) at the midspan between Posts 14 and 15, and the system's working width was 1,260 mm (50 in.). The vehicle and barrier damage is shown in Figure 5(a). A summary of the test results and the sequential photographs are shown in Figure 4. Test NPG-4 conducted on Design A was determined to be acceptable according to the *NCHRP Report 350* safety performance criteria.

Crash Test NPG-6—Design B

For Test NPG-6, a 2,001-kg (4,411-lb) pickup truck struck the Midwest Guardrail System with reduced post spacing (Design B) at a speed of 96.8 km/h (60.2 mph) and an angle of 25.6°. Initial impact occurred 2,946 mm (116 in.) upstream from the centerline of Post 29, as shown in Figure 6. At 0.297 s after impact, the vehicle became parallel to the guardrail with a resultant velocity of 59.5 km/h (37.0 mph). The vehicle was safely redirected in a stable manner with very little roll or pitch. At 0.491 s, the vehicle exited the guardrail at a trajectory angle of 12.9° and a resultant velocity of 59.5 km/h (37.0 mph). Exterior vehicle damage was moderate, consisting of right-front corner deformations. Minimal interior occupant compartment deformations occurred, with only slight deformations of the floorboard. Damage to the barrier was moderate, consisting mostly of deformed W-beam and guardrail posts, contact marks on a guardrail section, and disengaged wooden blockouts. Maximum dynamic barrier deflection was 447 mm (18 in.) at the centerline of Post 27, and the system's working width was 931 mm (37 in.). The vehicle and barrier

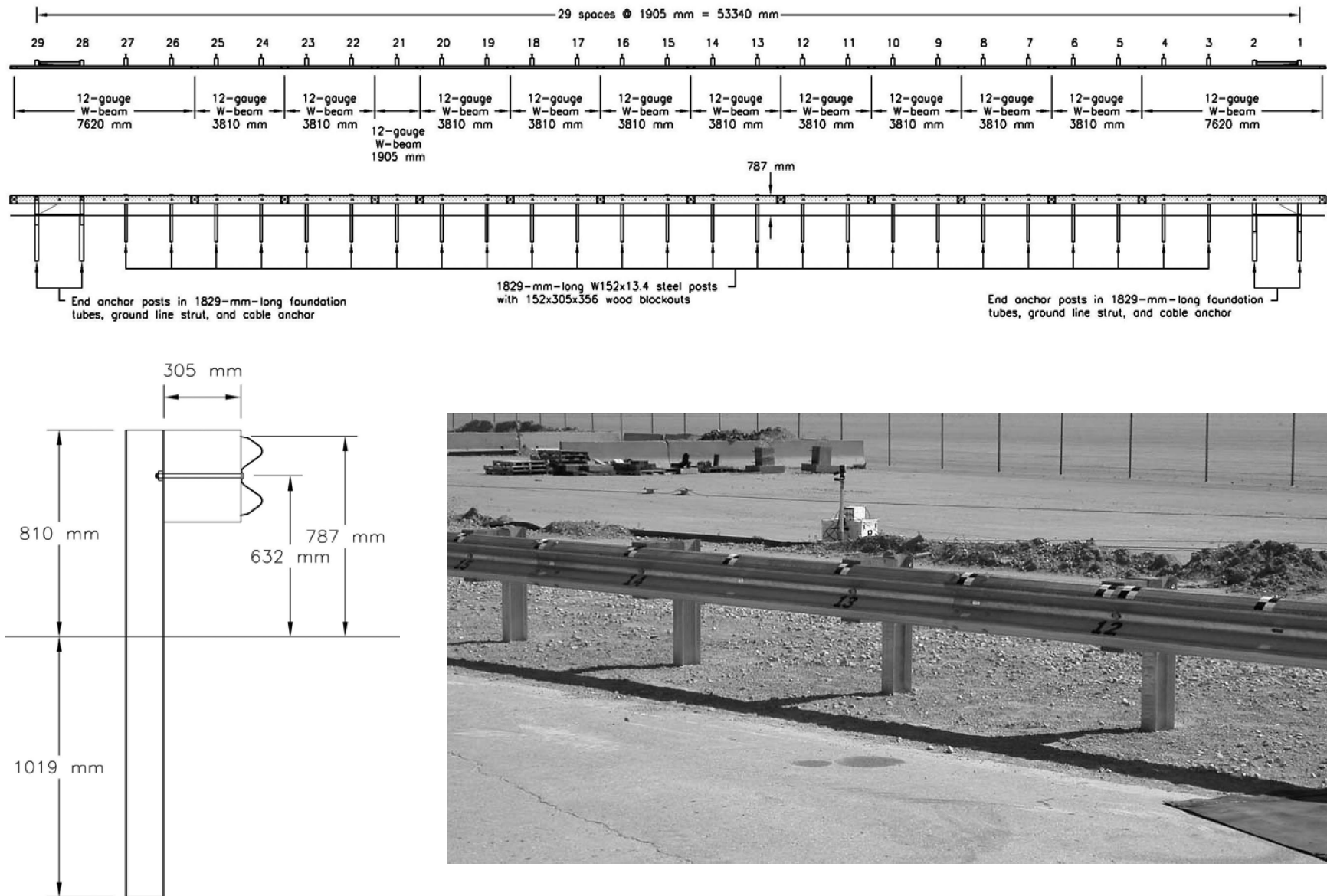
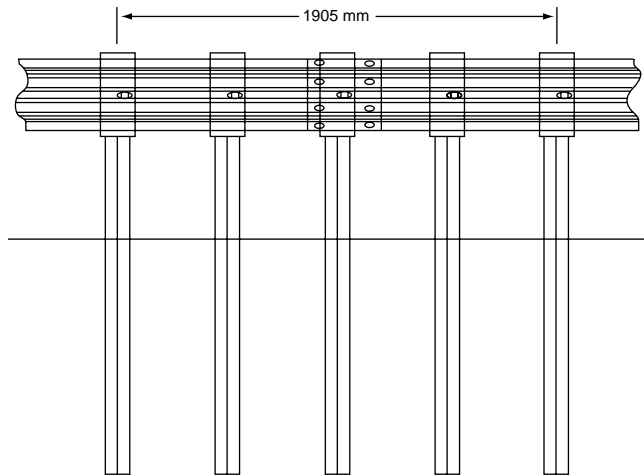
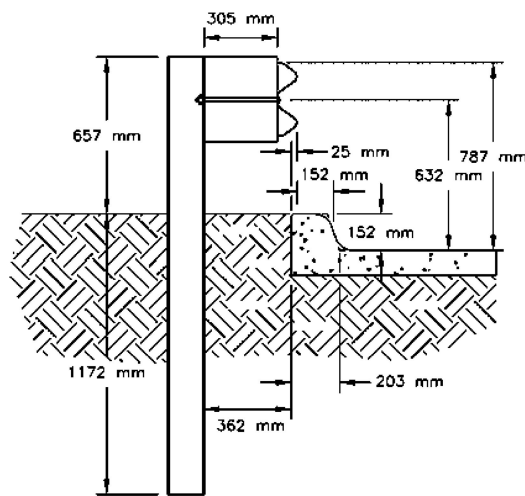

FIGURE 2 Midwest Guardrail System: standard post spacing design details (Design A) (1 in. = 25.4 mm).



(a)



(b)

FIGURE 3 Midwest Guardrail System for special applications: (a) quarter-post spacing (Design B); (b) standard post spacing with AASHTO Type B curb (Design C) (1 in. = 25.4 mm).

damage is shown in Figure 5(b). A summary of the test results and the sequential photographs are shown in Figure 6. Test NPG-6 conducted on Design B was determined to be acceptable according to the *NCHRP Report 350* safety performance criteria.

Crash Test NPG-5—Design C

For Test NPG-5, a 1,988-kg (4,383-lb) pickup truck struck the Midwest Guardrail System installed over a concrete curb (Design C) at a speed of 96.6 km/h (60.0 mph) and an angle of 25.8°. Initial impact occurred 4,547 mm (179 in.) upstream from the centerline of the splice between Posts 14 and 15, as shown in Figure 7. At 0.518 s after impact, the vehicle became parallel to the guardrail with a resultant velocity of 52.3 km/h (32.5 mph). Before exiting the system, the vehicle encountered moderate roll away from the rail and moderate pitching toward its left-front corner. At 0.718 s, the vehicle exited the guardrail at an orientation angle of 6.7 degrees and a resultant velocity of 48.0 km/h (29.8 mph). Exterior vehicle

damage was moderate, consisting of right-front corner deformations, and there was no observable occupant compartment deformation. Damage to the barrier was moderate, consisting mostly of deformed W-beam and guardrail posts, an uprooted guardrail post, contact marks on a guardrail section, and disengaged wooden block-outs. Maximum dynamic barrier deflection was 1,024 mm (40 in.) at the midspan between Posts 14 and 15, and the system's working width was 1,625 mm (64 in.). The vehicle and barrier damage is shown in Figure 5(c). A summary of the test results and the sequential photographs are shown in Figure 7. Test NPG-5 conducted on Design C was determined to be acceptable according to the *NCHRP Report 350* safety performance criteria.

COMPUTER SIMULATION MODELING

Nonlinear, two-dimensional computer simulation modeling with BARRIER VII (28) was used to analyze and predict the dynamic performance of the Midwest Guardrail System. This analysis included a

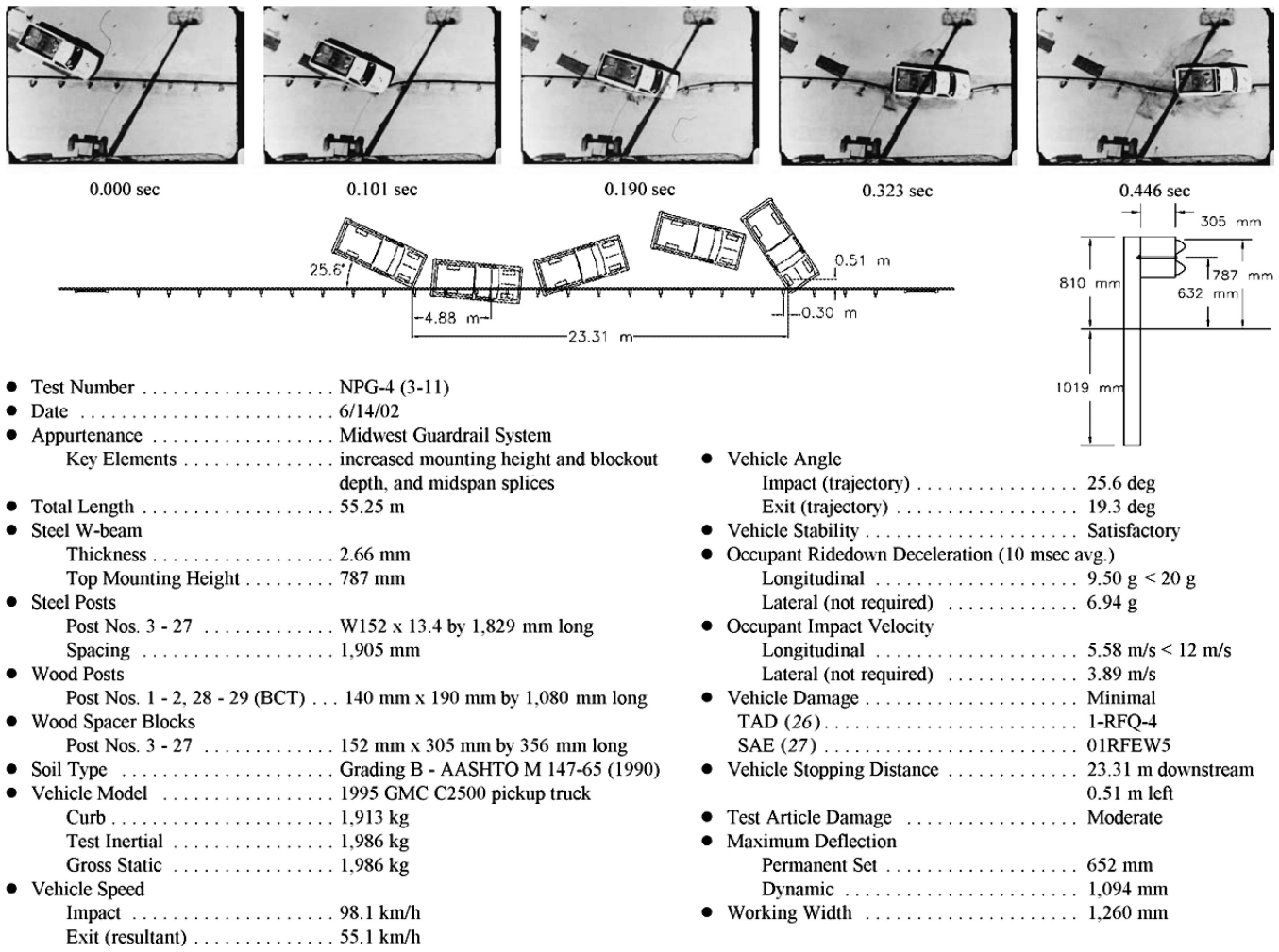

FIGURE 4 Summary of results and sequential photographs, Test NPG-4 (1 in. = 25.4 mm).

calibration and validation of the pickup truck crash tests performed on both the standard (Test NPG-4) and reduced (Test NPG-6) post spacing designs. For the validation effort, several simulations were performed at the impact conditions of the two crash tests to calibrate selected BARRIER VII input parameters. For the posts, initial parameters were obtained from the dynamic post testing, as shown in Figure 8(a). Other parameters worth noting include post failure displacement based on guardrail release, vehicle-to-barrier dynamic coefficient of friction, and yaw mass moment of inertia for the pickup truck. The data acquired from the overhead high-speed film, onboard vehicle accelerometers, and speed traps were used to calibrate vehicle simulations to the two physical tests.

The calibration effort began with the development of a finite element model for the standard post spacing design (Design A). On the basis of a parametric technique, initial simulations showed a need to tune input parameters for posts located both in the impact region and at the ends. It was also necessary to adjust the vehicle-to-rail friction coefficient and the vehicle's yaw mass moment of inertia to more accurately predict vehicle behavior at the parallel and exit conditions. The final validated BARRIER VII input parameters for Test NPG-4 are provided in Figure 8(a). Graphical comparisons of the simulated and actual barrier displacements for Test NPG-4 are provided in Figure 8(b). As shown in Figure 8(b), BARRIER VII

had some difficulty fully reproducing the guardrail shape near the upstream end of the deformed region. However, during the actual test, the vehicle's rear end pitched up and protruded over the rail during redirection. Since BARRIER VII is limited to planar motion, it is unable to reproduce roll and pitch angular motions. Therefore, it would calculate vehicle tail slap into the barrier, potentially increasing the predicted barrier displacements in this region. Tabulated validation results for vehicle behavior, barrier displacements, and working width for Test NPG-4 are shown in Figure 8(c). From this effort, researchers determined that the final simulation accurately predicted barrier performance and vehicle behavior for the standard post spacing configuration.

Once the calibration effort was completed for Test NPG-4, simulations commenced on the reduced post spacing design (Design B), which was evaluated by Test NPG-6. Using the same parametric evaluation, researchers determined that the final post properties used in the NPG-4 validation effort were appropriate for the NPG-6 simulations as well. However, it was necessary to increase the vehicle-to-rail friction coefficient from 0.400 to 0.475 to more accurately predict vehicle behavior. Initially, it may seem unreasonable to adjust the vehicle-to-barrier friction coefficient, since it should be the same for comparable guardrail tests. However, wheel contact and snag on additional posts effectively caused additional vehicle



(a)



(b)



(c)

FIGURE 5 Barrier and vehicle damage: (a) Test NPG-4; (b) Test NPG-6; (c) Test NPG-5.

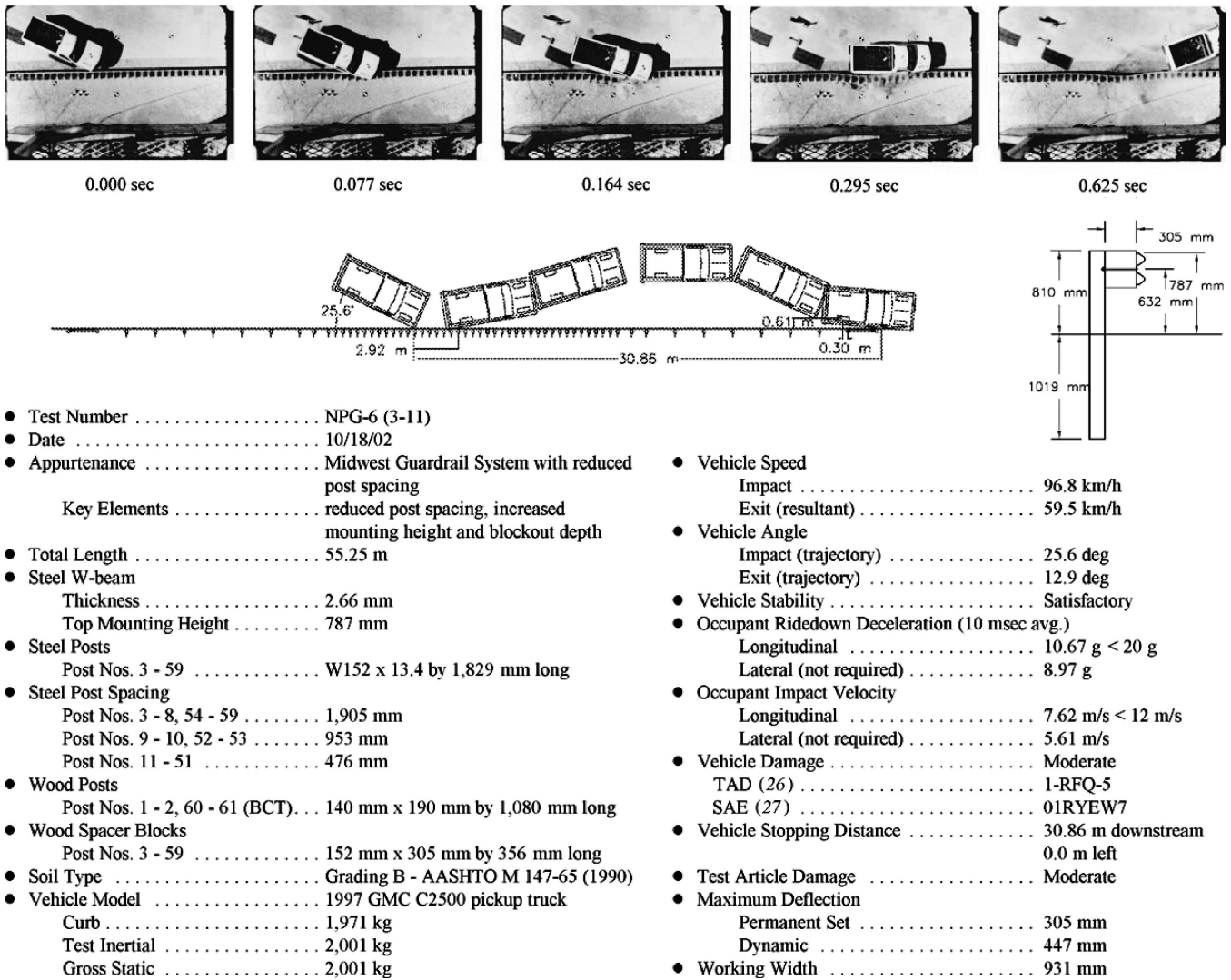

FIGURE 6 Summary of results and sequential photographs, Test NPG-6 (1 in. = 25.4 mm).

drag and energy loss in the actual system that BARRIER VII cannot predict. Therefore, adjustment of the effective coefficient of friction was deemed appropriate. Graphical comparisons of the simulated and actual barrier displacements for Test NPG-6 are provided in Figure 8(b). Tabulated validation results for vehicle behavior, barrier displacements, and working width for Test NPG-6 are shown in Figure 8(c). Once again, researchers determined that the final simulation accurately predicted barrier performance and vehicle behavior for the reduced post spacing configuration.

In addition, researchers compared the longitudinal and lateral accelerations and changes in the vehicle's velocity after the final NPG-4 and NPG-6 validation runs were completed. Therefore, the same SAE filtering procedures outlined in *NCHRP Report 350* were applied to the simulation data to obtain channel frequency class (CFC) 60 (100-Hz) vehicle accelerations and CFC 180 (300-Hz) changes in velocity and to analytical data acquired with the same sample rate. Figure 9 shows the results. For the NPG-4 comparison, BARRIER VII generally predicted the acceleration trends but could not predict peaks. While peak accelerations could not be reproduced, changes in vehicle velocity were reasonably accurate through approximately 300 ms or close to a vehicle parallel condition. For the NPG-6 compar-

ison, BARRIER VII predicted the acceleration trends more accurately than observed in the NPG-4 comparisons. However, it was once again incapable of predicting peak accelerations. More important, though, BARRIER VII was accurate in predicting vehicle changes in velocity for the stiffened barrier configuration.

For this study, BARRIER VII modeling was also used to predict overall guardrail performance and working width for the standard, half-, and quarter-post designs at the TL-3 impact conditions. These results would later be used to provide guidance for determining appropriate guardrail placement practices. Each post configuration was evaluated by using an analysis technique to determine the critical impact point (CIP) for the three designs. Simulations were performed on each design and at incremental distances along the rail to determine the predicted maximum dynamic rail deflection as well as an estimate for the maximum working width. The working width for a given barrier design should be used to determine the appropriate guardrail placement in front of and for shielding a rigid hazard. Based on a CIP analysis for the three systems, a maximum dynamic rail deflection of 1,059, 705, and 447 mm (41.7, 27.8, and 17.6 in.) was observed for the standard, half-, and quarter-post spacing designs, respectively. Similarly, each barrier's working width, based on engine

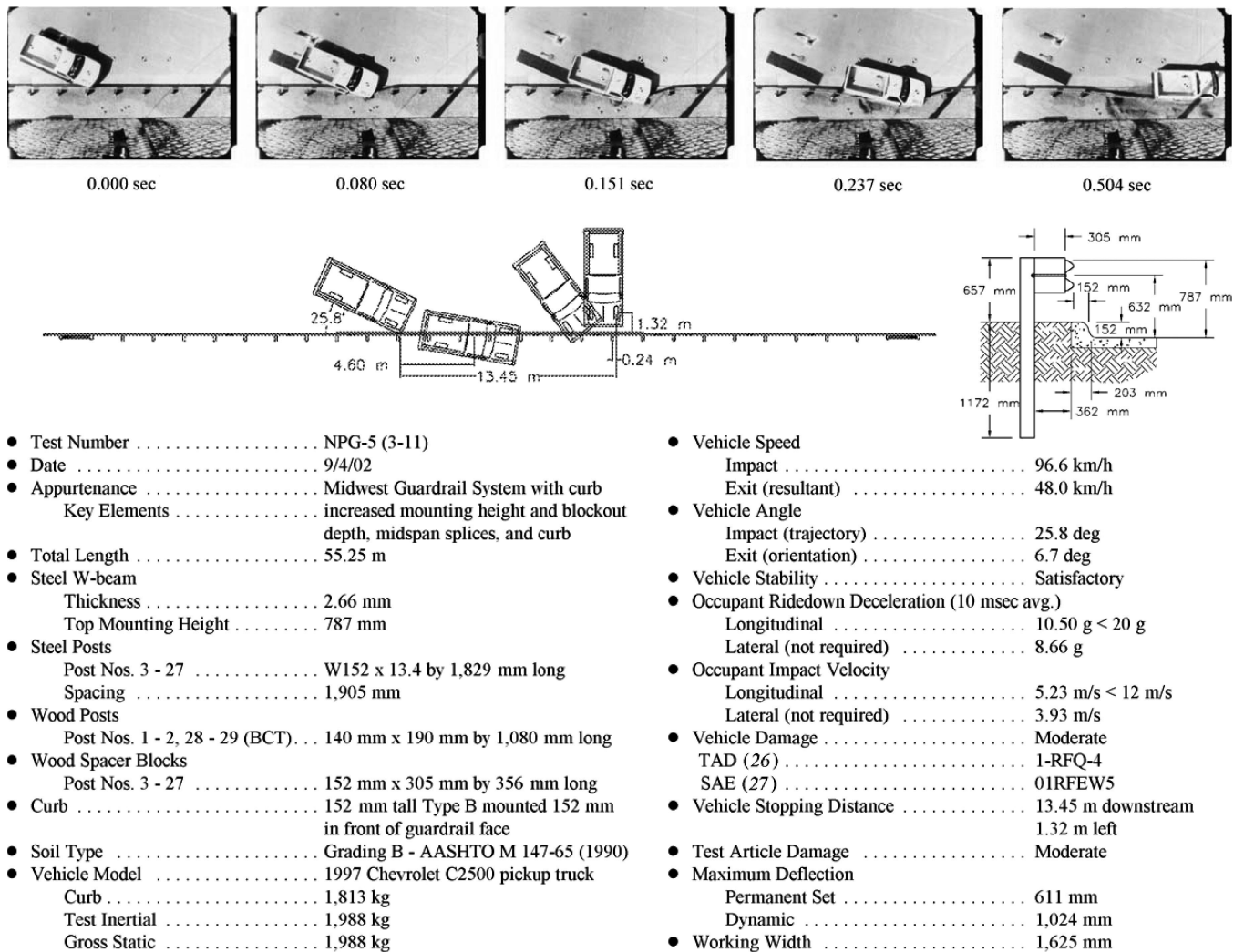

FIGURE 7 Summary of results and sequential photographs, Test NPG-5 (1 in. = 25.4 mm).

hood extension over the rail, was found to be 1,230, 976, and 815 mm (48.4, 38.4, and 32.1 in.) for the standard, half-, and quarter-post spacing designs, respectively. In addition, each barrier's working width, based on the lateral position of the back of the post, was found to be 1,391, 1,094, and 871 mm (54.8, 43.1, and 34.3 in.) for the standard, half-, and quarter-post spacing designs, respectively. Although the working width was governed by post displacement for the standard post spacing design, it is unlikely that the post would remain attached to the rail for that displacement. Therefore, if governed by intrusion of the corner of the engine hood, the working width would be 1,230 mm (48.4 in.).

GUARDRAIL PLACEMENT GUIDELINES

As previously discussed, one research objective was to determine guardrail placement guidelines for shielding roadside obstacles by using the standard Midwest Guardrail System as well as the two stiffened variations. On the basis of an analysis of the test and simulation results, the minimum recommended distances that should separate the Midwest Guardrail System from a rigid hazard are 1.25, 1.12, and 0.90 m (49, 44, and 35 in.) for the standard, half-, and quarter-post

spacing designs, respectively, as measured from the front face of the W-beam rail to the front face of the hazard.

SUMMARY, CONCLUSIONS, AND RECOMMENDATIONS

Development of the Midwest Guardrail System was continued to provide increased safety for high-center-of-mass vehicles, provide improved height tolerances, and reduce the potential for W-beam rupture. The barrier system performed well for small car impacts when it was mounted as high as 813 mm (32 in.) and performed very well during light truck impacts for the standard top mounting height of 787 mm (31 in.) for three different placement situations. The standard Midwest Guardrail System design performed well for the standard configuration with a post spacing of 1,905 mm (6 ft 3 in.), for a quarter-post spacing of 476 mm (1 ft 6¾ in.), and for placement 152 mm (6 in.) behind a concrete curb 152 mm (6 in.) high. In each test, the Midwest Guardrail System safely redirected the ¾-ton truck in a stable manner. The test results clearly indicate that the new barrier will reduce the high rollover rates currently associated with light truck impacts on standard guardrail designs. Furthermore, in every

BARRIER VII Parameters	Input Values			
	Initial Run	NPG-4 Final Validation Run	NPG-6 Final Validation Run	Half Post Spacing Predictions
K_B - Post Stiffness Along B (strong axis) (kN/mm)	1.021	1.056	1.056	1.056
K_A - Post Stiffness Along A (weak axis) (kN/mm)	0.701	0.701	0.701	0.701
M_A - Moment About A (strong axis) (kN*mm)	18549	16230	16230	16230
M_B - Moment About B (weak axis) (kN*mm)	10494	10494	10494	10494
δ_F - Failure Displacement Along B (mm)	381	381	381	381
μ_k - Kinetic Friction Coefficient (Vehicle to Rail)	0.350	0.400	0.475	0.425
I_{mZ} - 2000P Mass Moment of Inertia - Yaw ($N*m*s^2$)	4971	5356	5356	5356

(a)

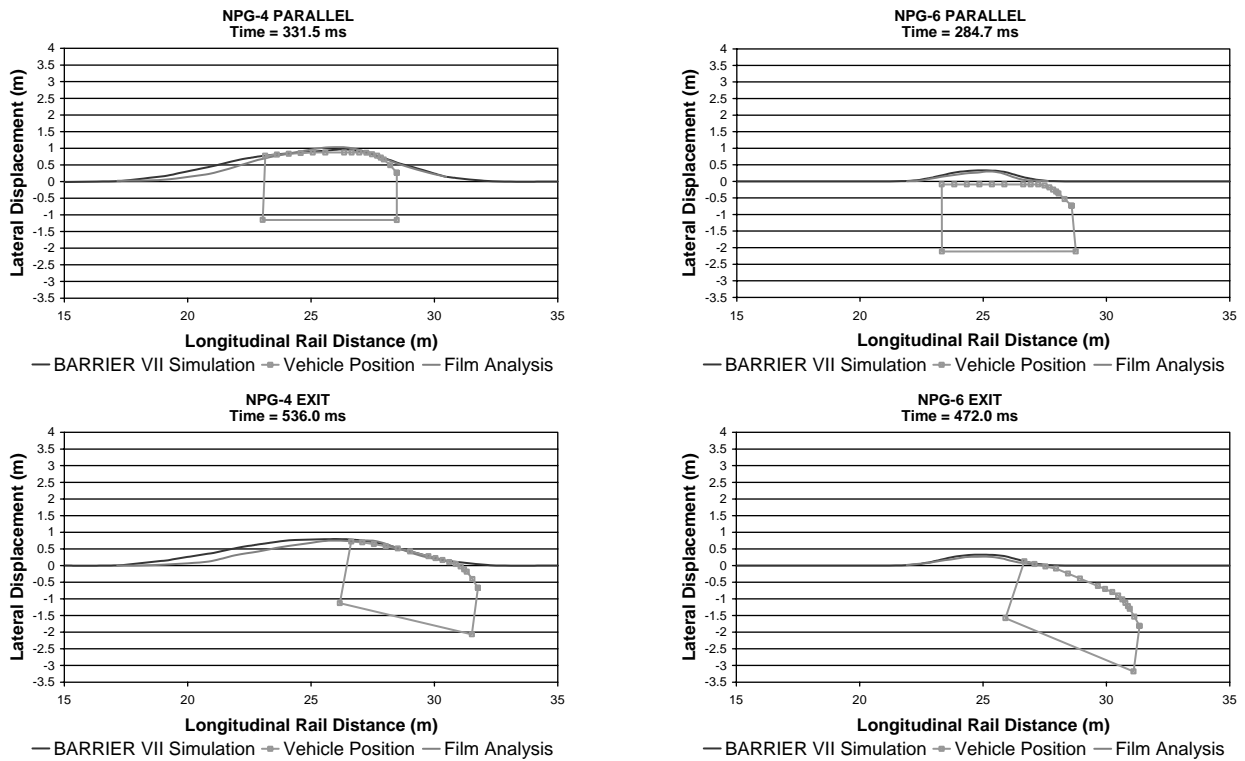

(b)

Evaluation Parameters	Results Comparison			
	1905-mm Post Spacing		476.25-mm Post Spacing	
	Test No. NPG-4	Simulation	Test No. NPG-6	Simulation
Parallel Time (ms)	396.4	331.5	296.8	284.7
Dynamic Rail Deflection (mm)	1094	1054	447	418
Working Width (mm)	1260	1391*	931	845
Working Width Indicator	Hood Corner	Post*	Post	Post
Exit Time (ms)	596.6	536.0	490.6	472.0
Exit Angle (degrees)	8.8	9.9	17.5	17.1
Exit Velocity Vector (degrees)	19.4	13.2	12.9	14.4
Resultant Velocity at Exit (km/h)	55.1	56.26	59.5	50.44

*Although the post was the working width indicator, it is unlikely that the post would remain attached to the rail for that displacement. If the working width is governed by the engine/hood corner intrusion, the estimated working width would be 1235 mm.

(c)

FIGURE 8 BARRIER VII calibration and validation: (a) selected simulation input parameters; (b) graphical comparison of barrier displacements; (c) tabulated results of actual test data and BARRIER VII simulation.

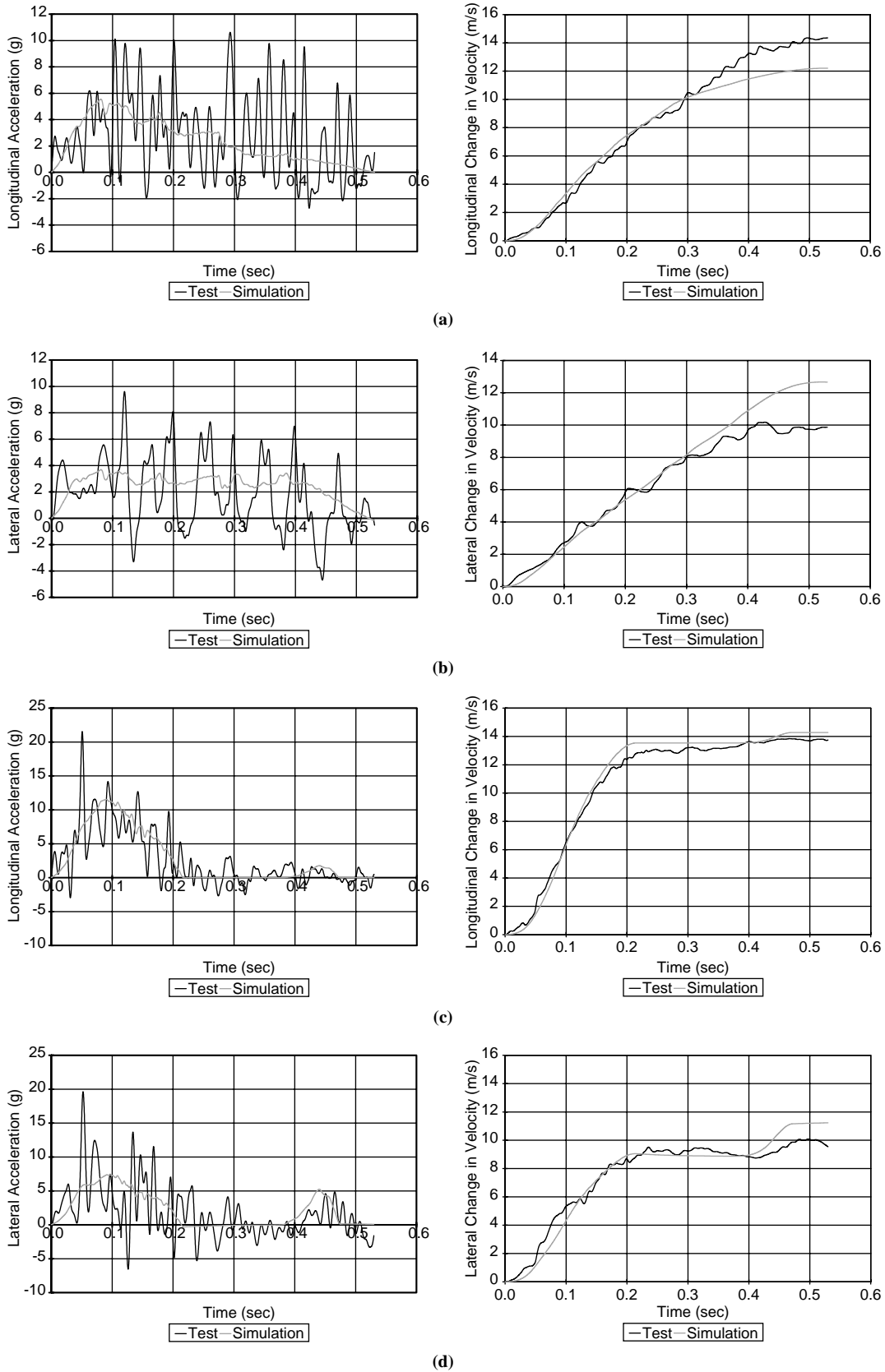

FIGURE 9 Comparison of test and simulation results: (a) longitudinal direction, NPG-4; (b) lateral direction, NPG-4; (c) longitudinal direction, NPG-6; (d) lateral direction, NPG-6 (1 in. = 25.4 mm).

pickup truck test conducted thus far on the Midwest Guardrail System, the test vehicle was brought to a safe stop immediately adjacent to the barrier. Thus, the Midwest Guardrail System will provide improved safety for light truck impacts, not only by reducing the propensity for rollover during high speed/high angle impacts but also by keeping the vehicles close to the guardrail, thereby eliminating the potential for secondary impacts with other vehicles.

A combination of full-scale crash testing, dynamic component testing, and computer simulation was also used to identify maximum barrier deflections and working widths for the Midwest Guardrail System installed with standard, half-, and quarter-post spacings. As previously provided, these guidelines should allow designers to use the new barrier with confidence, even when fixed hazards are located near the face of the guardrail.

Unfortunately, two problems remain to be resolved before the Midwest Guardrail System can be fully implemented. No guardrail system can be widely implemented without an acceptable method for terminating the barrier. Therefore, existing guardrail terminal designs must be adapted to the new mounting height before the Midwest Guardrail System can be used. Higher guardrail mounting heights may allow small cars to penetrate under the impact heads and buffer nose sections used on the ends of W-beam guardrail. Furthermore, both the increased height and the associated reduction in post embedment depth have been shown to increase the loading on guardrail terminal anchors. Therefore, the revised designs must be retested at the beginning of the length-of-need with a $\frac{3}{4}$ -ton pickup truck. Finally, the raised height and reduced embedment depth and anchorage may also create problems for small cars striking the barrier upstream of the beginning of length-of-need. Hence, it is strongly recommended that manufacturers conduct three full-scale crash tests on the currently approved guardrail terminal systems attached to the Midwest Guardrail System before the design is implemented widely.

One of the most common applications for W-beam guardrails is on the approach to bridge railings. Hence, another barrier to implementation of the Midwest Guardrail System is the development of acceptable guardrail/bridge rail transitions. Most guardrail/bridge rail transition designs incorporate three beam rail elements with a top height of 787 mm (31 in.). These designs incorporate a three beam-to-W-beam transition element that allows the center of the W-beam and three beam rails to be mounted at the same height. To attach the Midwest Guardrail System to these transition systems, a revised three beam that flares downward must be successfully tested. This effort is currently under way, and it is hoped that the testing will be completed before the beginning of the 2004 construction season.

In summary, the Midwest Guardrail System development is nearing completion. All testing conducted to date indicates that by reducing the propensity for causing rollovers, the new barrier will offer greatly improved protection for occupants of light trucks. The new barrier was developed with funding from the Midwest States' Pooled Fund program and is entirely nonproprietary. Highway agencies are strongly encouraged to consider adopting the new barrier system as soon as FHWA acceptance letters are issued for the guardrail system and the modified terminals and transitions.

ACKNOWLEDGMENTS

The authors acknowledge several sources that made contributions to this project: the Midwest States' Pooled Fund Program funded by the state departments of transportation of Connecticut, Iowa, Kansas, Minnesota, Missouri, Montana, Nebraska, Ohio, South

Dakota, Texas, and Wisconsin for sponsoring this project; and the MwRSF personnel for constructing the barriers and conducting the crash tests.

REFERENCES

1. Buth, C. E., W. L. Campise, L. I. Griffin III, M. L. Love, and D. L. Sicking. *Performance Limits of Longitudinal Barrier Systems—Volume I—Summary Report*. Report FHWA/RD-86/153. Texas Transportation Institute, College Station, May 1986.
2. Ross, H. E., Jr., D. L. Sicking, R. A. Zimmer, and J. D. Michie. *NCHRP Report 350: Recommended Procedures for the Safety Performance Evaluation of Highway Features*. TRB, National Research Council, Washington, D.C., 1993.
3. Mak, K. K., R. P. Bligh, and W. L. Menges. *Testing of State Roadside Safety Systems—Volume 11: Appendix J—Crash Testing and Evaluations of Existing Guardrail Systems*. Research Study RF 471470, draft final report. Texas Transportation Institute, College Station, Dec. 1995.
4. Buth, C. E., W. L. Menges, and D. L. Ivey. W-Beam Guardrail. Presented at 78th Annual Meeting of the Transportation Research Board, Washington, D.C., 1999.
5. Polivka, K. A., D. L. Sicking, J. R. Rohde, R. K. Faller, and J. C. Holloway. *Crash Testing of Michigan's Type B (W-Beam) Guardrail System*. Transportation Research Report TRP-03-90-99. Midwest Roadside Safety Facility, University of Nebraska—Lincoln, Nov. 1999.
6. Polivka, K. A., D. L. Sicking, J. R. Rohde, R. K. Faller, and J. C. Holloway. *Crash Testing of Michigan's Type B (W-Beam) Guardrail System—Phase II*. Transportation Research Report TRP-03-104-00. Midwest Roadside Safety Facility, University of Nebraska—Lincoln, Dec. 2000.
7. Bligh, R. P., W. L. Menges, and B. G. Butler. *Evaluation of a Modified Steel Post W-Beam Guardrail System*. Report TX-98/3963-S. Texas Transportation Institute, College Station, Nov. 1997.
8. Bligh, R. P., and W. L. Menges. *Testing and Evaluation of a Modified Steel Post W-Beam Guardrail System with Recycled Polyethylene Blockouts*. Report 400001-MPT. Texas Transportation Institute, College Station, Feb. 1997.
9. Bullard, D. L., Jr., W. L. Menges, and D. C. Alberson. *NCHRP Report 350 Compliance Test 3-11 of the Modified G4(1S) Guardrail with Timber Blockouts*. Report FHWA-RD-96-175. Texas Transportation Institute, College Station, Sept. 1996.
10. Bligh, R. P., and D. L. Bullard. *Crash Testing and Evaluation of Round, Wood Post, W-Beam Guardrail System*. Research Study 405391. Texas Transportation Institute, College Station, Oct. 1995.
11. Sicking, D. L., J. D. Reid, and J. R. Rohde. Development of the Midwest Guardrail System. In *Transportation Research Record: Journal of the Transportation Research Board, No. 1797*, TRB, National Research Council, Washington, D.C., 2002, pp. 44–52.
12. Polivka, K. A., R. K. Faller, D. L. Sicking, J. D. Reid, J. R. Rohde, J. C. Holloway, R. W. Bielenberg, and B. D. Kuipers. *Development of the Midwest Guardrail System (MGS) for Standard and Reduced Post Spacing and in Combination with Curbs*. MwRSF Research Report TRP-03-139-04. Midwest Roadside Safety Facility, University of Nebraska—Lincoln, Feb. 2004.
13. Kuipers, B. D., and J. D. Reid. *Testing of W152 × 23.8 (W6 × 16) Steel Posts—Soil Embedment Depth Study for the Midwest Guardrail System (Nonproprietary Guardrail System)*. MwRSF Research Report TRP-03-136-03. Midwest Roadside Safety Facility, University of Nebraska—Lincoln, June 2003.
14. Hallquist, J. O. *LS-DYNA Keyword User's Manual—Version 960*. Livermore Software Technology Corporation, Livermore, Calif., 2001.
15. Holloway, J. C., M. G. Bierman, B. G. Pfeifer, B. T. Rosson, and D. L. Sicking. *Performance Evaluation of KDOT W-Beam Systems—Volume I: Full-Scale Crash Testing*. Transportation Research Report TRP-03-39-96, Project SPR-3(17). Midwest Roadside Safety Facility, University of Nebraska—Lincoln, May 1996.
16. Holloway, J. C., M. G. Bierman, B. G. Pfeifer, B. T. Rosson, and D. L. Sicking. *Performance Evaluation of KDOT W-Beam Systems—Volume II: Component Testing and Computer Simulation*. Transportation Research Report TRP-03-39-96, Project SPR-3(17). Midwest Roadside Safety Facility, University of Nebraska—Lincoln, May 1996.

17. Rosson, B. T., M. G. Bierman, and J. R. Rohde. Assessment of Guardrail-Strengthening Techniques. In *Transportation Research Record 1528*, TRB, National Research Council, Washington, D.C., 1996, pp. 69–77.
 18. *Determination of Strengthened Guardrail Deflection*. Federal Highway Administration, U.S. Department of Transportation, May 18, 1989.
 19. *Roadside Design Guide*. AASHTO, Washington D.C., 2002.
 20. Bullard, D. L., Jr., and W. L. Menges. *NCHRP Report 350 Test 3-11 of the G4(2W) Strong Post W-Beam Guardrail with 100-mm High Asphaltic Curb*. Reports FHWA-RD-00 and 404202-1. Texas Transportation Institute, College Station, June 2000.
 21. Polivka, K. A., R. K. Faller, D. L. Sicking, J. R. Rohde, J. D. Reid, and J. C. Holloway. *Guardrail and Guardrail Terminals Installed over Curbs*. Transportation Research Report TRP-03-83-99, Project SPR-3(017)-Year 8. Midwest Roadside Safety Facility, University of Nebraska–Lincoln, March 2000.
 22. Polivka, K. A., R. K. Faller, D. L. Sicking, J. R. Rohde, J. D. Reid, and J. C. Holloway. *Guardrail and Guardrail Terminals Installed over Curbs—Phase II*. Transportation Research Report TRP-03-105-00, Project No. SPR-3(017)-Year 10. Midwest Roadside Safety Facility, University of Nebraska–Lincoln, Nov. 2001.
 23. Stout, D., W. Hughes, and H. McGee. *Traffic Barriers on Curves, Curbs, and Slopes*. Report FHWA-RD-93-082. ENSCO, Inc., Springfield, Va., Oct. 1993.
 24. Ivey, D. L., R. Robertson, and C. E. Buth. *Test and Evaluation of W-Beam and Thrie-Beam Guardrails*. Report FHWA/RD-82/071. Texas Transportation Institute, College Station, March 1986.
 25. Ross, H. E., Jr., H. S. Perera, D. L. Sicking, and R. P. Bligh. *NCHRP Report 318: Roadside Safety Design for Small Vehicles*. TRB, National Research Council, Washington, D.C., 1989.
 26. *Vehicle Damage Scale for Traffic Investigators*, 2nd ed. Technical Bulletin 1, Traffic Accident Data Project. National Safety Council, Chicago, Ill., 1971.
 27. *Collision Deformation Classification—Recommended Practice J224 March 1980*. Handbook Volume 4. SAE, Warrendale, Pa., 1985.
 28. Powell, G. H. *BARRIER VII: A Computer Program for Evaluation of Automobile Barrier Systems*. Report FHWA RD-73-51. FHWA, April 1973.
-
- The contents of this paper reflect the views of the authors, who are responsible for the facts and accuracy of the data presented. The contents do not necessarily reflect the official views or policies of the state highway departments participating in the Midwest States' Regional Pooled Fund Research Program or the Federal Highway Administration. This paper does not constitute a standard, specification, or regulation.*
- Publication of this paper sponsored by Roadside Safety Design Committee.*