

DISCLAIMER: The use of this standard is governed by the "Texas Engineering Practice Act". No warranty of any kind is made by TxDOT for any purpose whatsoever. TxDOT assumes no responsibility for the conversion of this standard to other formats or for incorrect results or damages resulting from its use.

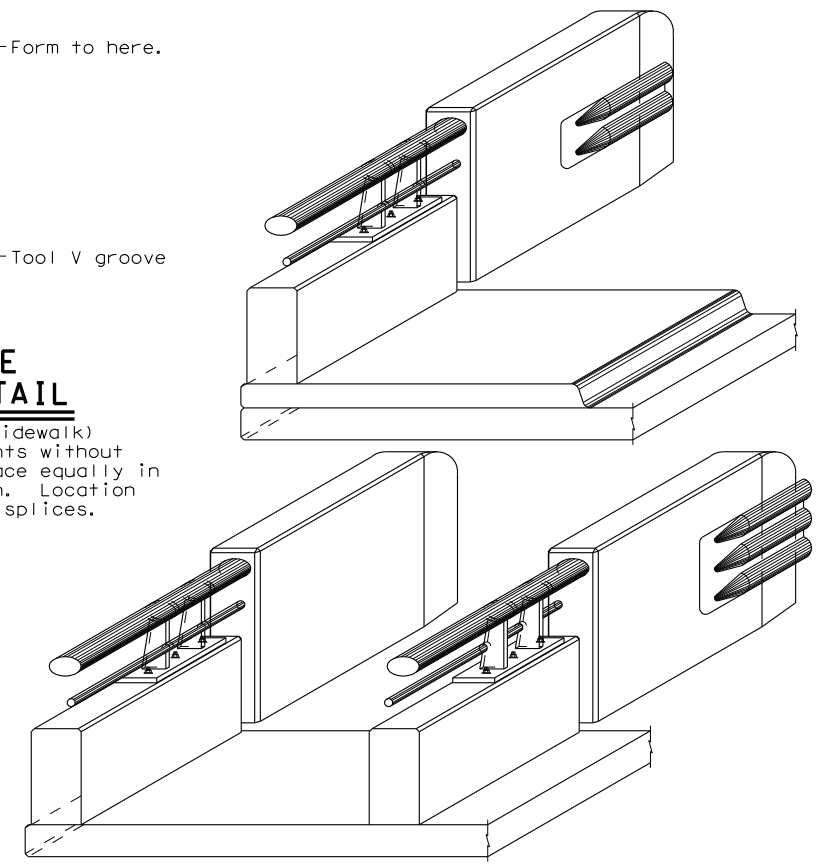
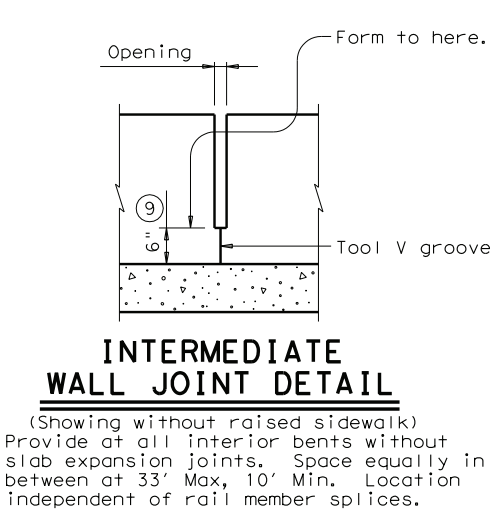
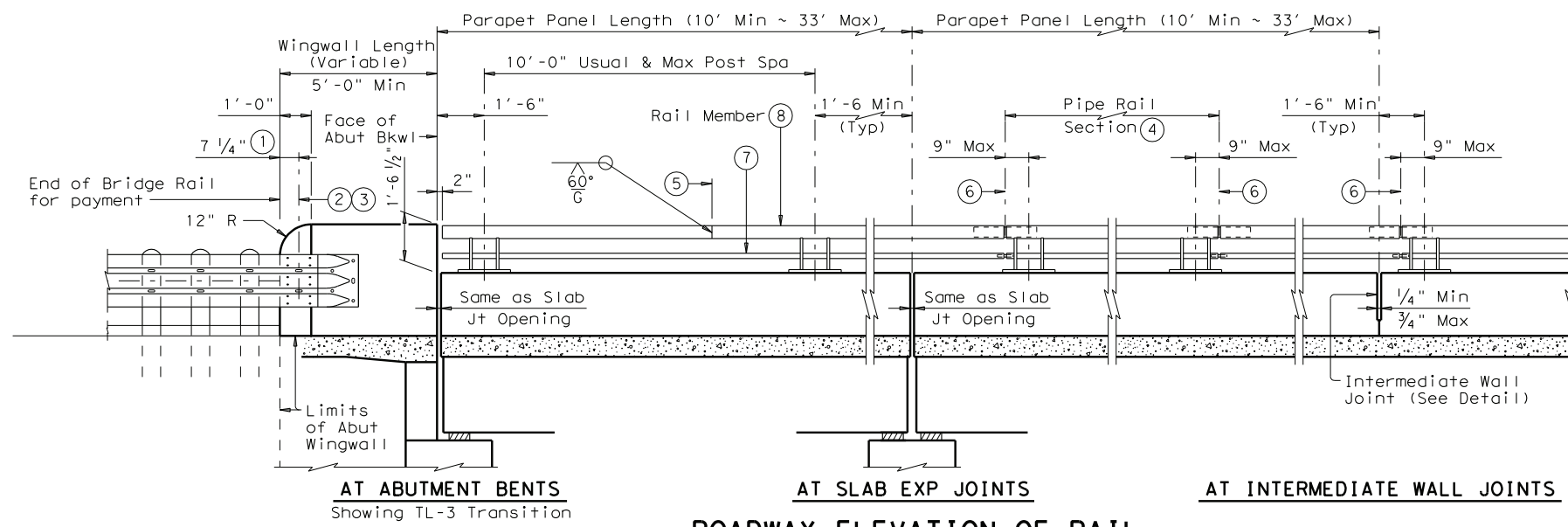

INTERMEDIATE WALL JOINT DETAIL
 (Showing without raised sidewalk)
 Provide at all interior bents without slab expansion joints. Space equally in between at 33' Max, 10' Min. Location independent of rail member splices.

ISOMETRIC VIEWS AT END OF BRIDGE

(Rail Member showing Elliptical Tube Option, Rectangular Tube Option similar).

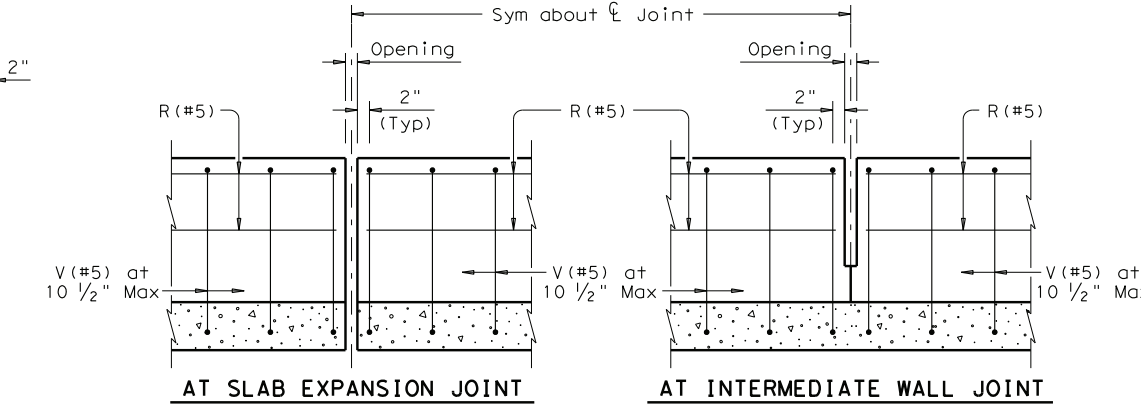

ELEVATION SHOWING TYPICAL REINFORCING PLACEMENT

(Showing without raised sidewalk)

- ① Showing TL-3 Splice location, TL-2 Splice location is 1'-0".
- ② $\bar{\bar{C}}$ Splice ~ Metal Beam Guard Fence Transitions must be attached to the bridge rail and extended along the embankment unless otherwise shown in the plans.
- ③ Terminal Connectors and associated hardware are to be paid for under the Item "Metal Beam Guard Fence".
- ④ Pipe rail sections must have at least two posts but not more than four.
- ⑤ One shop splice per pipe rail section is permitted with minimum 85 percent penetration. The weld may be square groove or single vee groove. Grind smooth.
- ⑥ $\bar{\bar{C}}$ Exp Jt or Splice Jt as required.
- ⑦ 2" Dia Std Pipe (2.375" O.D., 0.154" wall thickness) ASTM-A53 Gr B or A500 Gr B. Placed on sidewalk side of rail.
- ⑧ Unless directed otherwise by the Engineer, the fabricator may use the rectangular tube in lieu of the elliptical tube for the rail member.
- ⑨ Increase 2" for structures with overlay.
- ⑩ Bolts must be of sufficient length to extend $\frac{1}{2}$ " to $\frac{3}{4}$ " beyond nut.
- ⑪ Bolt recesses are only required when pedestrian sidewalks are adjacent to back of rail.
- ⑫ 4 additional Bars R(#5) 3'-8" in length shall be placed inside Bars U(#5) and centered 2'-0" from end of rail when Terminal Connections are required. Field bend as needed.

ROADWAY ELEVATION OF RAIL

(Rail Member showing Elliptical Tube Option, Rectangular Tube Option similar).

$\bar{\bar{C}}$ 4 ~ 1" Dia holes and 2 1/2" Dia x 2" deep recesses. Holes and recesses must be formed or cored. Percussion drilling is not permitted. Adjust placement of reinforcing steel as necessary to avoid bolt holes and recesses. ①

$\bar{\bar{C}}$ 4 ~ 7/8" Dia A325 Bolts with two 1 3/4" O.D. washers. Place washer under each head and nut. ⑩ ③

AT ABUTMENT BENTS
Showing TL-3 Transition

AT SLAB EXP JOINTS

AT INTERMEDIATE WALL JOINTS

TL-2 TERMINAL CONNECTION DETAILS

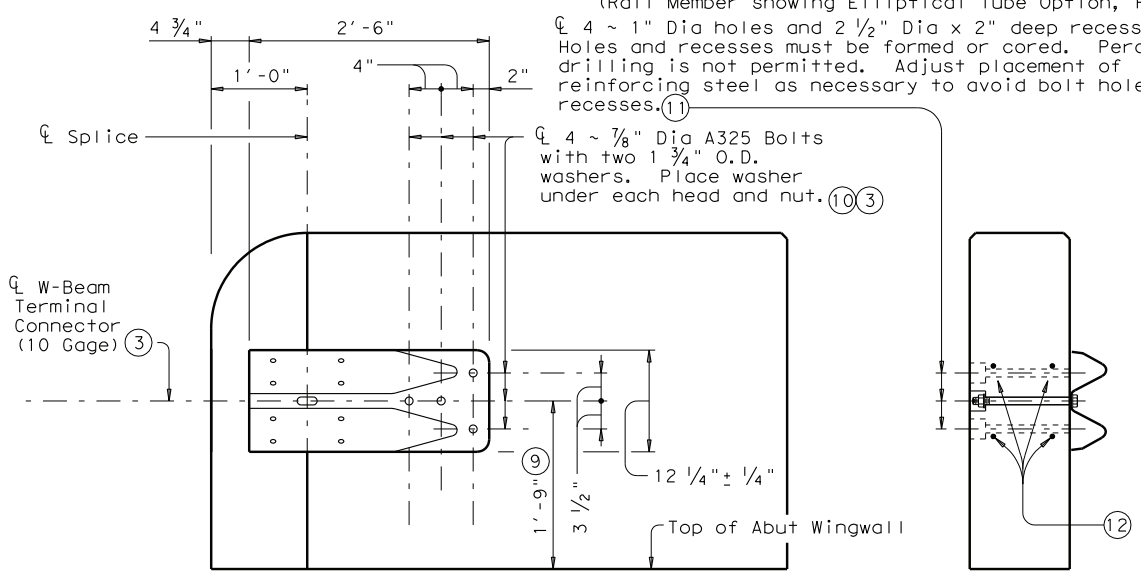

ELEVATION

SECTION

TL-2 TERMINAL CONNECTION DETAILS

$\bar{\bar{C}}$ 5 ~ 1" Dia holes and 2 1/2" Dia x 2" deep recesses. Holes and recesses must be formed or cored. Percussion drilling is not permitted. Adjust placement of reinforcing steel as necessary to avoid bolt holes and recesses. ①

$\bar{\bar{C}}$ 5 ~ 7/8" Dia A325 Bolts with two 1 3/4" O.D. washers. Place washer under each head and nut. ⑩ ③

TL-3 TERMINAL CONNECTION DETAILS

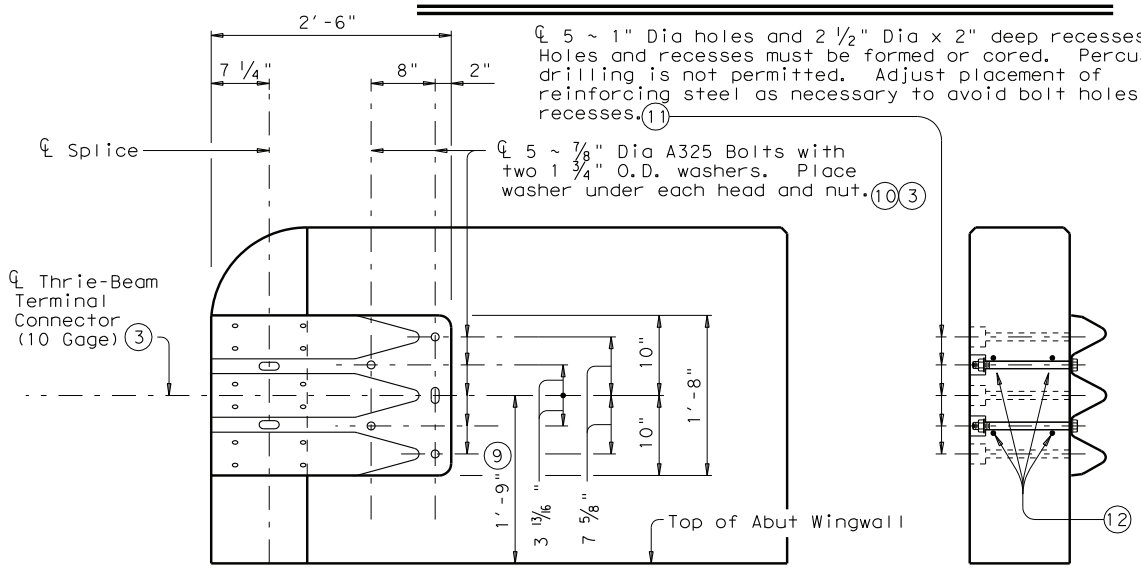

ELEVATION

SECTION

TL-3 TERMINAL CONNECTION DETAILS

COMBINATION RAIL

TYPE C402

| | | | | |
|-----------------------------------|-----------|---------------------|---------|---------|
| FILE: r1std020.dgn | DN: TxDOT | CK: TxDOT | DW: JTR | CK: JMH |
| © TxDOT April 2009 | DISTRICT | FEDERAL AID PROJECT | | SHEET |
| REVISIONS | | | | |
| 05-11: Notes and Wall Joint Note. | COUNTY | CONTROL | SECT | JOB |
| | | | | HIGHWAY |

| | |
|------------------|------|
| LEVELS DISPLAYED | ACC: |
| 1 | |

DISCLAIMER: The use of this standard is governed by the "Texas Engineering Practice Act". No warranty of any kind is made by TxDOT for any purpose whatsoever. TxDOT assumes no responsibility for the conversion of this standard to other formats or for incorrect results or damages resulting from its use.

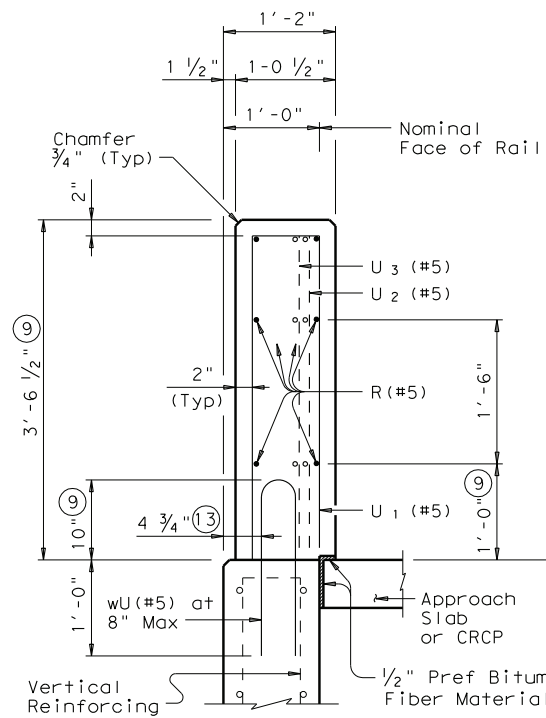

ON ABUTMENT WINGWALLS OR CIP RETAINING WALLS

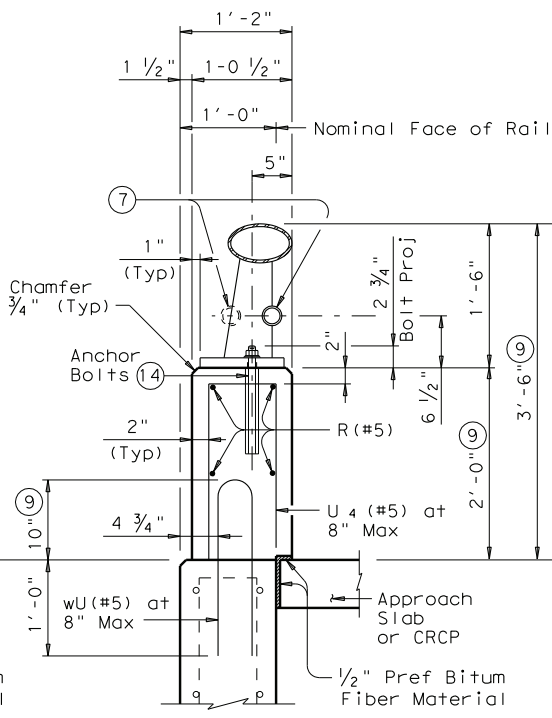

ON CIP RETAINING WALLS
(Showing Elliptical Tube Option)

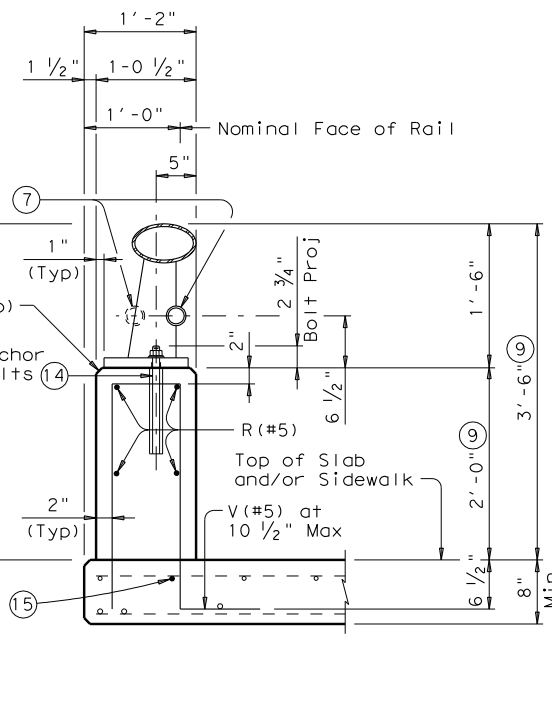

ON BRIDGE SLAB
(Showing Elliptical Tube Option)

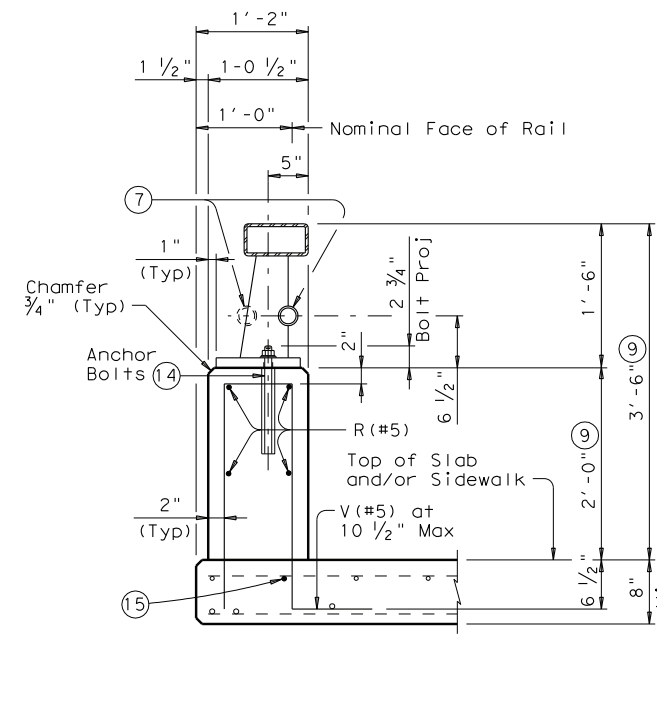

ON BRIDGE SLAB
(Showing Rectangular Tube Option)

SECTIONS THRU RAIL WITHOUT RAISED SIDEWALK ⑧

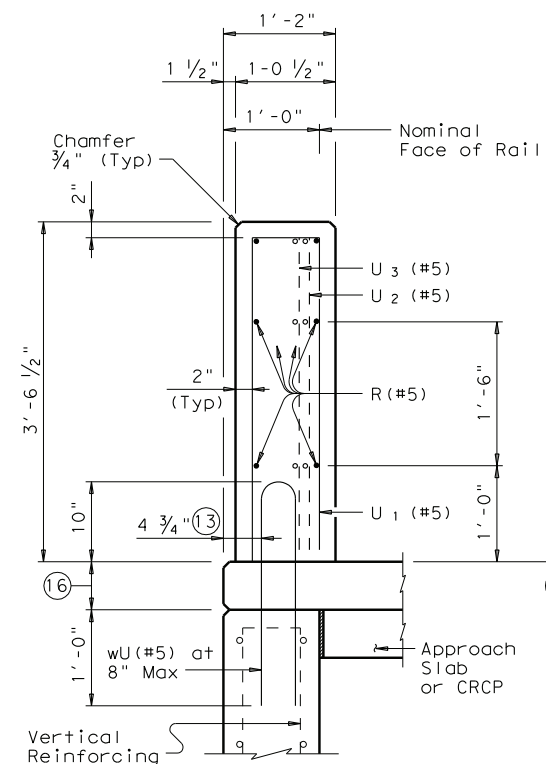

ON ABUTMENT WINGWALLS OR CIP RETAINING WALLS

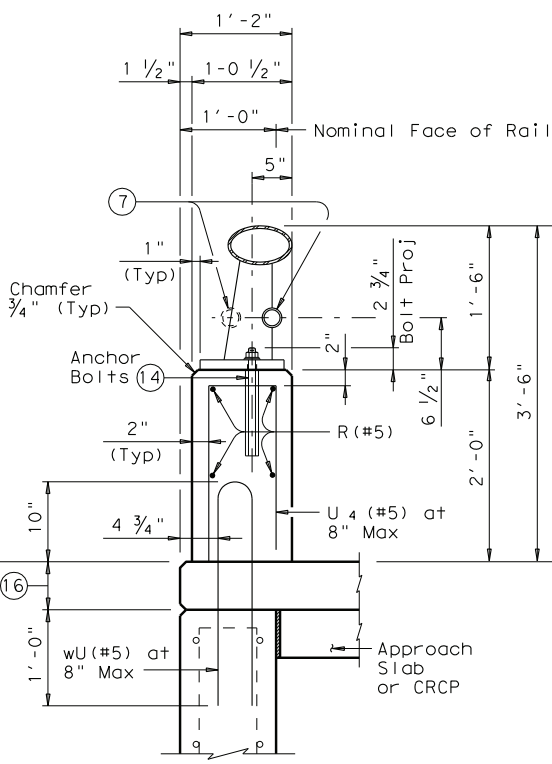

ON CIP RETAINING WALLS
(Showing Elliptical Tube Option)

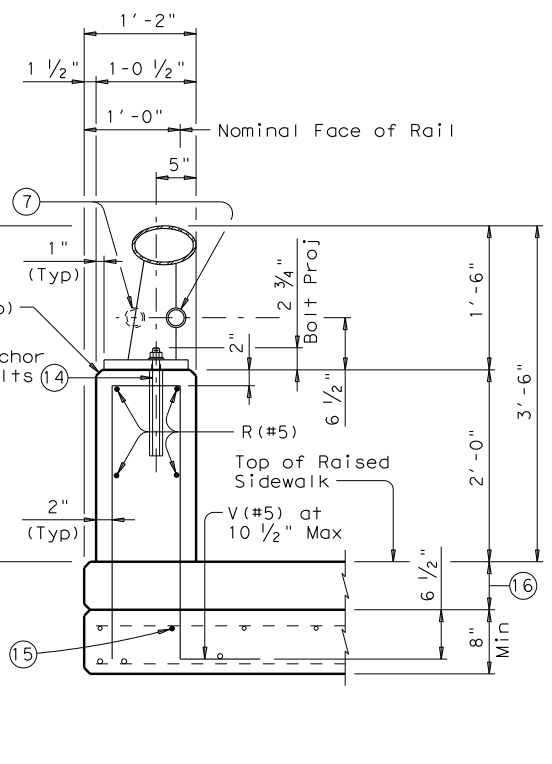

ON BRIDGE SLAB
(Showing Elliptical Tube Option)

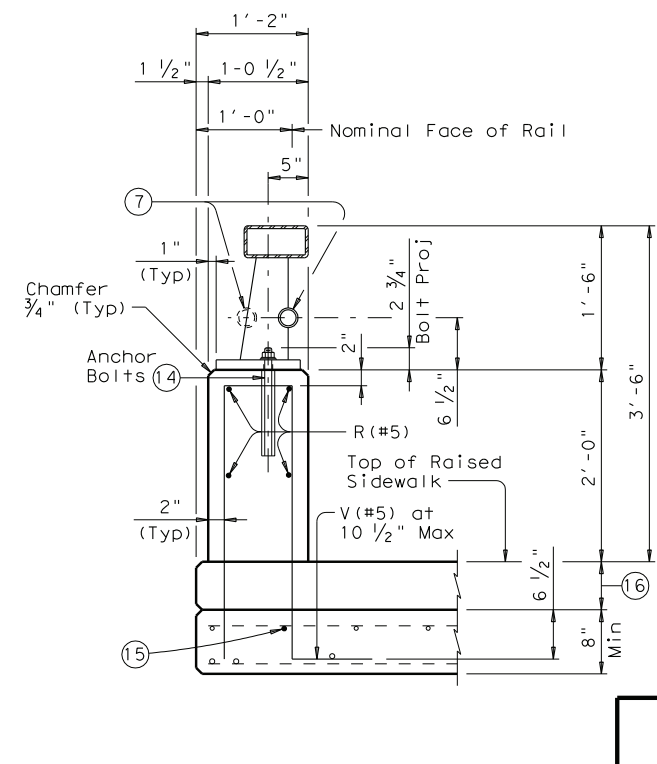

ON BRIDGE SLAB
(Showing Rectangular Tube Option)

SECTIONS THRU RAIL WITH RAISED SIDEWALK ⑧

- ⑦ 2" Dia Std Pipe (2.375" O.D., 0.154" wall thickness) ASTM-A53 Gr B or A500 Gr B. Placed on sidewalk side of rail.
- ⑧ Unless directed otherwise by the Engineer, the fabricator may use the rectangular tube in lieu of the elliptical tube for the rail member.
- ⑨ Increase 2" for structures with overlay.
- ⑬ 5 1/2" when vertical reinforcing has closer clear cover over horizontal reinforcing in abutment wingwalls or retaining walls on traffic side of wall.

- ⑭ See "Material Notes" for anchor bolt information.
- ⑮ Top longitudinal slab bar may be adjusted laterally 3" plus or minus to tie reinforcing.
- ⑯ Raised Sidewalk

COMBINATION RAIL

TYPE C402

| | | | | |
|-----------------------------------|-----------|---------------------|---------|---------|
| FILE: r1std020.dgn | DN: TxDOT | CK: TxDOT | DW: JTR | CK: JMH |
| © TxDOT April 2009 | DISTRICT | FEDERAL AID PROJECT | | SHEET |
| REVISIONS | | | | |
| 05-11: Notes and Wall Joint Note. | COUNTY | CONTROL | SECT | JOB |
| | | | | HIGHWAY |

ACC:

| | |
|------------------|--|
| LEVELS DISPLAYED | |
| 1 | |

DISCLAIMER: The use of this standard is governed by the "Texas Engineering Practice Act". No warranty of any kind is made by TxDOT for any purpose whatsoever. TxDOT assumes no responsibility for the conversion of this standard to other formats or for incorrect results or damages resulting from its use.

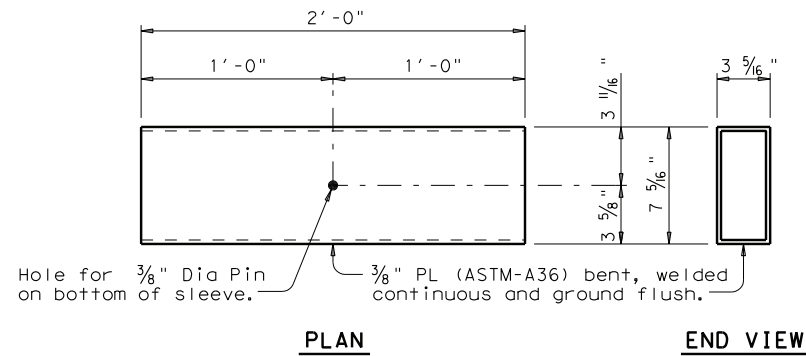

RECTANGULAR TUBE SLEEVE MEMBER DETAIL
(See Tube Fabrication Detail)

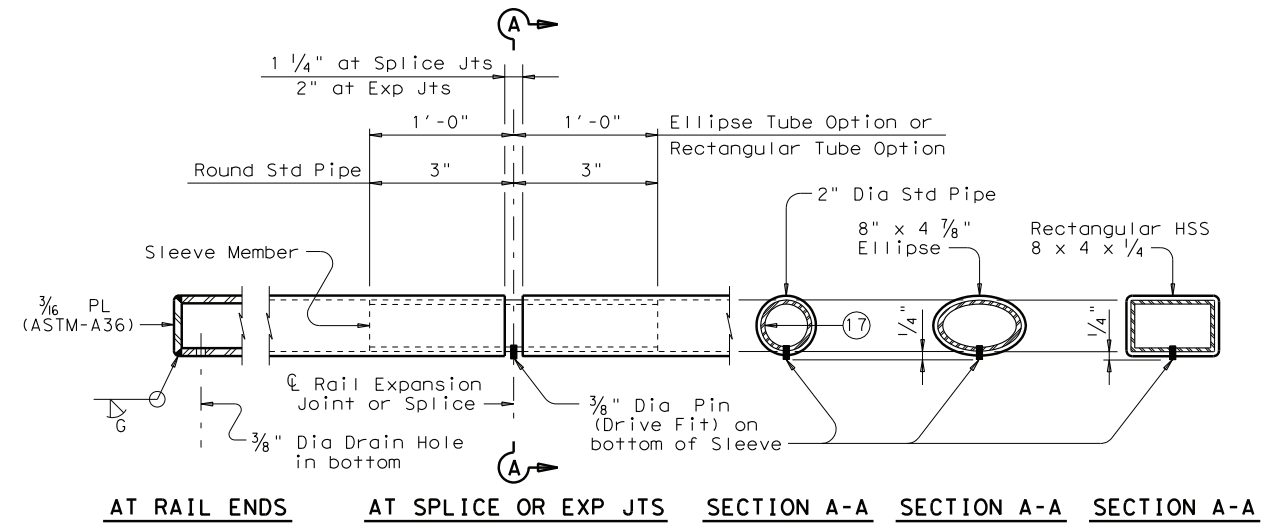

TUBE FABRICATION DETAILS ⑧

| ELLIPTICAL TUBE & ELLIPTICAL SLEEVE MEMBER | | |
|--|--------------------------|-----------|
| 8" x 4 7/8" Ellipse | Elliptical Sleeve Member | |
| Material | Material | Thickness |
| 6" Dia Std Pipe ASTM-A53 E or S Gr B | ASTM-A53 Gr B | 0.353" |
| | A36 or A500 Gr B | 0.339" |
| | API-5LX52 | 0.224" |
| 6 5/8" O.D. Pipe x 0.188" API-5LX52 | ASTM-A53 Gr B | 0.339" |
| | A36 or A500 Gr B | 0.325" |
| | API-5LX52 | 0.188" |

Notes: Other sections of equal or greater strength are acceptable for elliptical sleeves. The major and minor diameters of the rail member may vary +/- 0.1875" from plan dimension. However, the difference between the outside diameters of the elliptical sleeve and the inside diameters of the rail member must not exceed 0.25 inches.

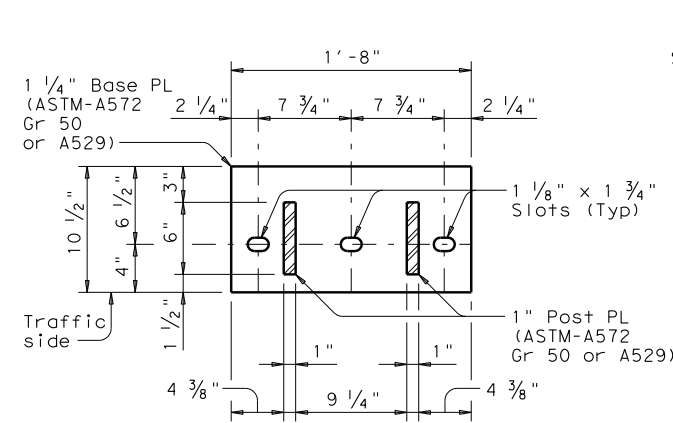

SECTION THRU POST

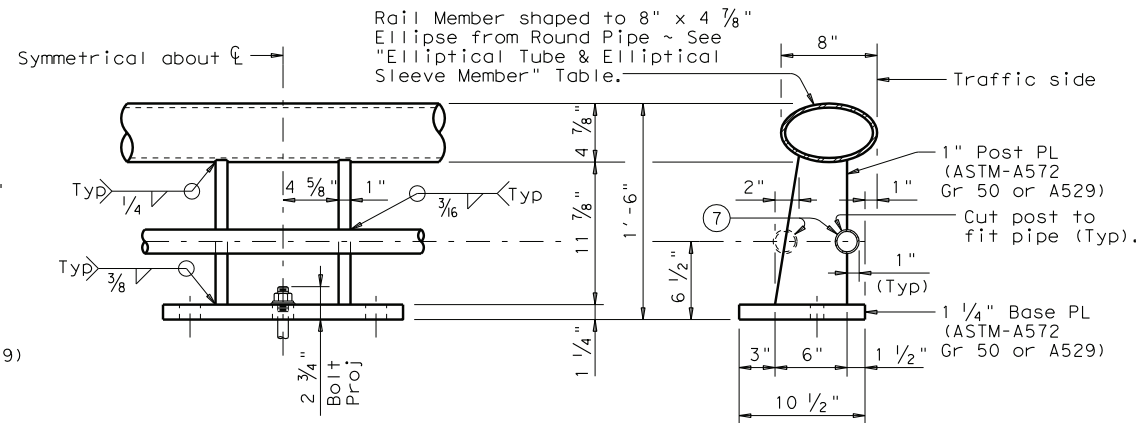

ELEVATION

SECTION THRU RAIL

ELLIPTICAL TUBE WITH RAIL POST & ANCHORAGE DETAILS

(Showing Elliptical Tube Option)

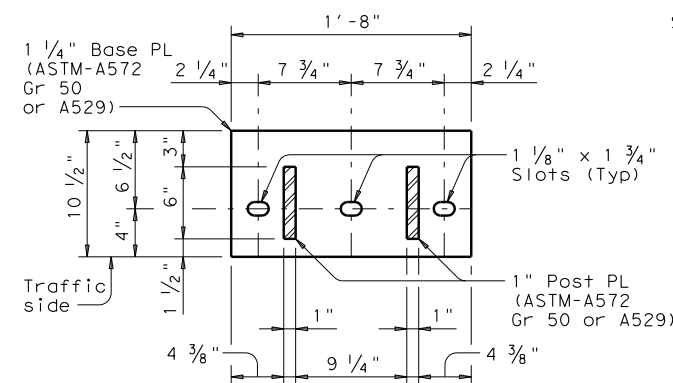

SECTION THRU POST

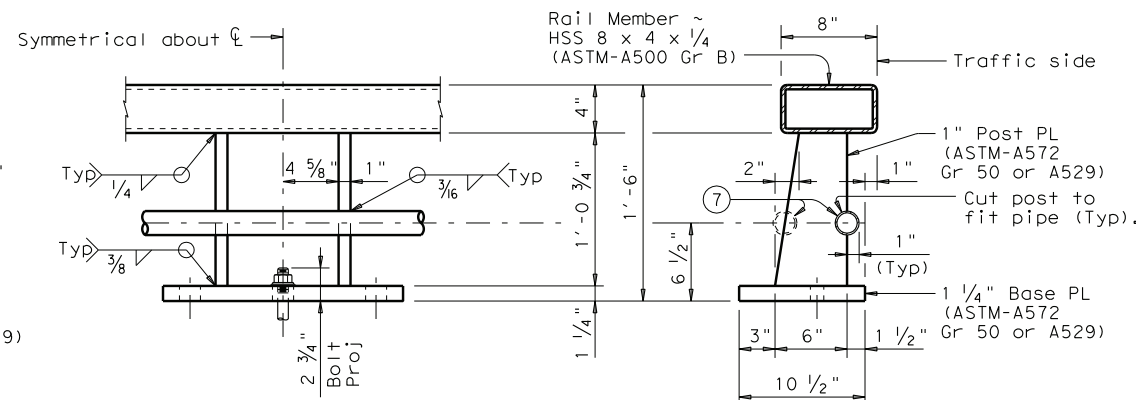

ELEVATION

SECTION THRU RAIL

RECTANGULAR TUBE WITH RAIL POST & ANCHORAGE DETAILS ⑧

(Showing Rectangular Tube Option)

- ⑦ 2" Dia Std Pipe (2.375" O.D., 0.154" wall thickness) ASTM-A53 Gr B or A500 Gr B. Placed on sidewalk side of rail.
- ⑧ Unless directed otherwise by the Engineer, the fabricator may use the rectangular tube in lieu of the elliptical tube for the rail member.
- ⑰ Sleeve Member 1 1/2" Dia Std Pipe (1.90" O.D., 0.145" wall thickness) ASTM-A53 Gr B or A500 Gr B.

SHEET 3 OF 4



COMBINATION RAIL

TYPE C402

| | | | | |
|-----------------------------------|-----------|---------------------|---------|-------------|
| FILE: r1std020.dgn | DN: TxDOT | CK: TxDOT | DW: JTR | CK: JMH |
| © TxDOT April 2009 | DISTRICT | FEDERAL AID PROJECT | | SHEET |
| REVISIONS | | | | |
| 05-11: Notes and Wall Joint Note. | COUNTY | CONTROL | SECT | JOB HIGHWAY |

| | |
|------------------|--|
| ACC: | |
| LEVELS DISPLAYED | |
| 1 | |

RAIL DATA FOR HORIZONTAL CURVES

| | RADIUS TO FACE OF RAIL | MAX CHORD LENGTH | CONSTRUCT OR FABRICATE |
|--------------|------------------------|------------------|---|
| Rail Members | Over 2800' | 29'-0" | Straight rail sections |
| | Over 1400' thru 2800' | 14'-6" | To required radius ⁽²⁰⁾ or to chords shown |
| | Over 700' thru 1400' | 7'-3" | |
| | Thru 700' | Zero | To required radius ⁽²⁰⁾ |

CONSTRUCTION NOTES:

This rail may be slip-formed if approved by the Engineer when epoxy adhesive anchor bolts are used.
 Cap all open ends of tubular steel sections.
 At the contractor's option anchor bolts may be cast with the parapet (See Cast-in-Place Anchor Bolt Options).
 Slip-forming parapet is not allowed if anchor bolts are cast with parapet wall.
 Rail parapet must be plumb unless otherwise approved by the Engineer. Steel posts must be square to the top of parapet. Use epoxy mortar under post base plates if gaps larger than 1/16" exist.
 Pipe rail sections must have at least two posts but not more than four.
 Round or chamfer all exposed edges of steel components 1/16" by grinding prior to galvanizing.

MATERIAL NOTES:

Galvanize all steel components except reinforcing steel.
 Anchor bolts must be 7/8" Dia ASTM A193 Grade B7 fully threaded rods with heavy hex nuts, one hardened washer and one (2 1/4" OD) washer each. Embed threaded rods into parapet wall with a Type III Class C epoxy anchorage system. Minimum embedment depth is 8". Anchorage system chosen must be able to achieve an ultimate tensile resistance of 34 kips per bolt. The Contractor must provide evidence to the Engineer that this can be achieved. Evidence of adequate tensile resistance can be based on the manufacturer's published values of ultimate tensile strength (anchor spacing and edge distance must be accounted for). Anchor installation, including hole size, drilling, and clean-out, must be in accordance with the manufacturer's instructions.
 Optional cast-in-place anchor bolts must be 7/8" Dia ASTM A325 or A449 bolts (or A193 Gr B7 threaded rods with one tack welded heavy hex nut each) with one heavy hex nut and one hardened steel washer plus one 2 1/4" O.D. steel washer at each bolt. Nuts must conform to A563 requirements.
 Use Class "C" concrete. Use Class "C" (HPC) if required elsewhere. Chamfer all exposed corners.
 Reinforcing steel must be Grade 60.
 Epoxy coat all rail reinforcement if slab bars are epoxy coated.

GENERAL NOTES:

This rail has been evaluated and accepted to be of equal strength to railings with like geometry, which have been crash tested to meet NCHRP Report 350 TL-3 criteria. This rail can be used for design speeds of 50 mph and greater when a TL-3 rated guard fence transition is used. When a TL-2 rated guard fence transition is used, this rail can only be used for design speeds of 45 mph and less.
 This railing cannot be used on bridges with expansion joints providing more than 5" movement.
 Rail anchorage details shown on this standard may require modification for select structure types. See appropriate details elsewhere in plans for these modifications.
 Erection drawings showing panel lengths, rail post spacing, and anchor bolt setting must be submitted to the Engineer for approval.
 Average weight of railing with no overlay: 347 plf total
 313 plf (Conc)
 34 plf (Steel).

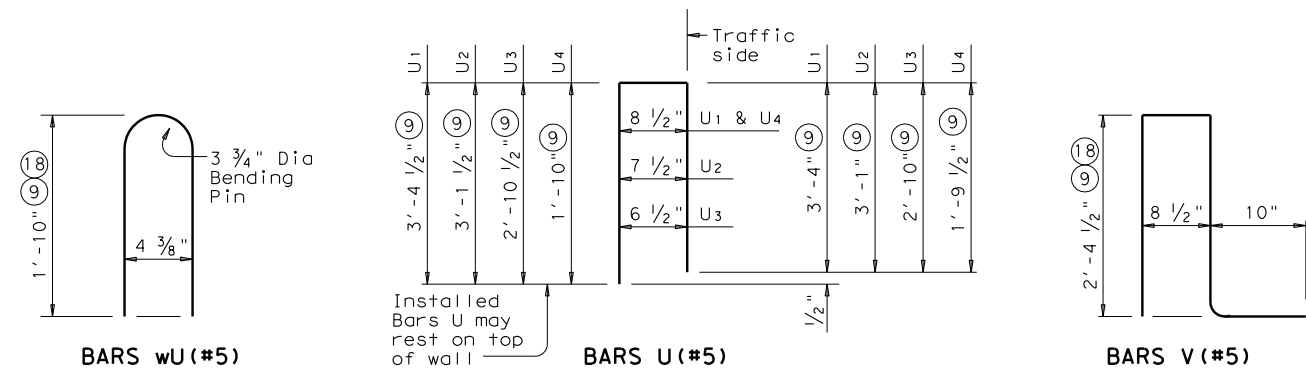

- (9) Increase 2" for structures with overlay.
- (14) See "Material Notes" for anchor bolt information.
- (18) For raised sidewalks, add sidewalk height to total bar height. Use sidewalk height at rail's location.
- (19) Slots are not allowed in areas where there is a joint in the concrete parapet between rail post.
- (20) Shop drawings for approval required for tubular steel sections.

DISCLAIMER: The use of this standard is governed by the "Texas Engineering Practice Act". No warranty of any kind is made by TxDOT for any purpose whatsoever. TxDOT assumes no responsibility for the conversion of this standard to other formats or for incorrect results or damages resulting from its use.

| | |
|------------------|------|
| LEVELS DISPLAYED | ACC: |
| 1 | |

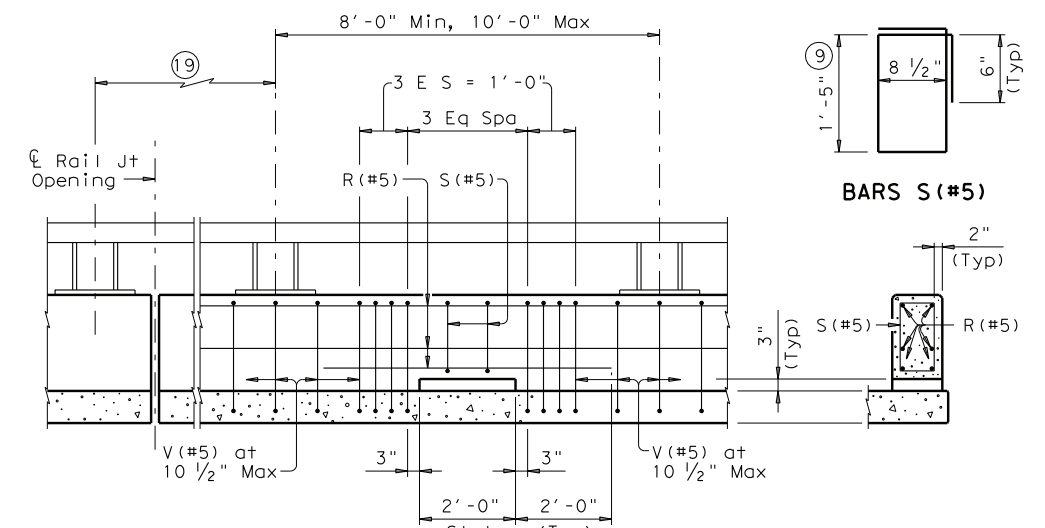

OPTIONAL SIDE SLOT DRAIN DETAILS

Note: Side Slot Drains must be centered between rail posts within the limits shown. Side Slot Drains may be used where shown elsewhere on the plans or as directed by the Engineer. Drains should not be placed over railroad tracks, lower roadways, or sidewalks. When this rail is used as a separator between a roadway surface and a sidewalk surface, side drain slots will not be permitted.

7/8" Dia Heavy Hex Head Anchor Bolt (ASTM-A325 or A449) or Threaded Rod (ASTM-A193 Gr B7) with one Hardened Steel Washer and one 2 1/4" O.D. Steel Washer placed under Heavy Hex Nut. One additional Heavy Hex Nut must be furnished for each Threaded Rod.

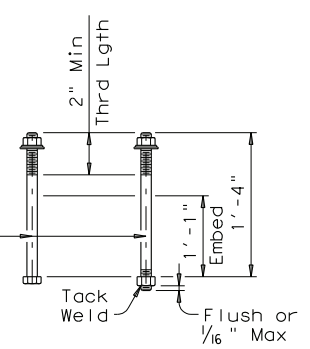

COMBINATION RAIL

TYPE C402

| | | | | |
|-----------------------------------|-----------|---------------------|---------|---------|
| FILE: r1std020.dgn | DN: TxDOT | CK: TxDOT | DW: JTR | CK: JMH |
| © TxDOT April 2009 | DISTRICT | FEDERAL AID PROJECT | | SHEET |
| REVISIONS | | | | |
| 05-11: Notes and Wall Joint Note. | COUNTY | CONTROL | SECT | JOB |
| | | | | HIGHWAY |