

ELEVATION

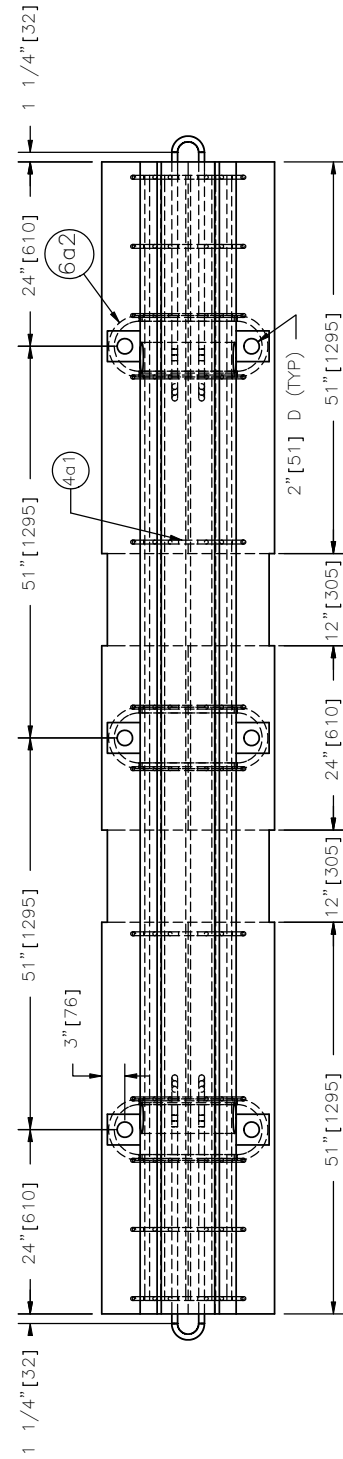

PLAN

PORTABLE F-SHAPE CONCRETE BARRIER ELEMENT



SWC09

SHEET NO.

DATE:

1 of 6

10/29/2008

SPECIFICATIONS

Concrete shall develop a minimum of 28-day concrete compressive strength of not less than 5 ksi [34.5 MPa]. The concrete shall use a Portland cement specified in AASHTO M85 (ASTM C1500 for Type I or II cement. Reinforcing steel shall be Grade 60 ksi [400 MPa] and shall conform to either of the following:

- Epoxy-coated deformed bars as specified in AASHTO M284M (ASTM D3963M).
- AASHTO M31M (ASTM A615M) deformed and plain billet steel reinforcing bars for use with calcium nitrite corrosion inhibitor (30% calcium nitrite solution.)

Fabricators should satisfy themselves that there is adequate reinforcement for hoisting, lifting, or otherwise handling the barriers. The reinforcement shown is primarily for the impact performance of the barrier. Additional reinforcement may be advisable for handling the barrier and ensuring its integrity over its service life.

Dimensions tolerances not shown or implied are intended to be those consistent with the proper functioning of the part, including its appearance and accepted manufacturing practices.

INTENDED USE

The Portable F-shape Concrete Barrier Element is non-proprietary and is the main rail element in the SWC10, SWC11, SWC12, and SWC04 pin and rebar portable concrete barrier. A suitable connector like the FWM01, FWM02, and FWM03 pin-and-rebar connector must be used to hold the SWC09 sections together. The Portable F-shape Concrete Barrier Element is TL-3 NCHRP 350 accepted, and is accepted according to MASH 08.

ACCEPTANCE

FHWA Acceptance Letter [B-122](#), October 2, 2003.

PORTABLE F-SHAPE CONCRETE BARRIER ELEMENT

SWC09



SHEET NO.

DATE:

2 of 6

10/29/2008

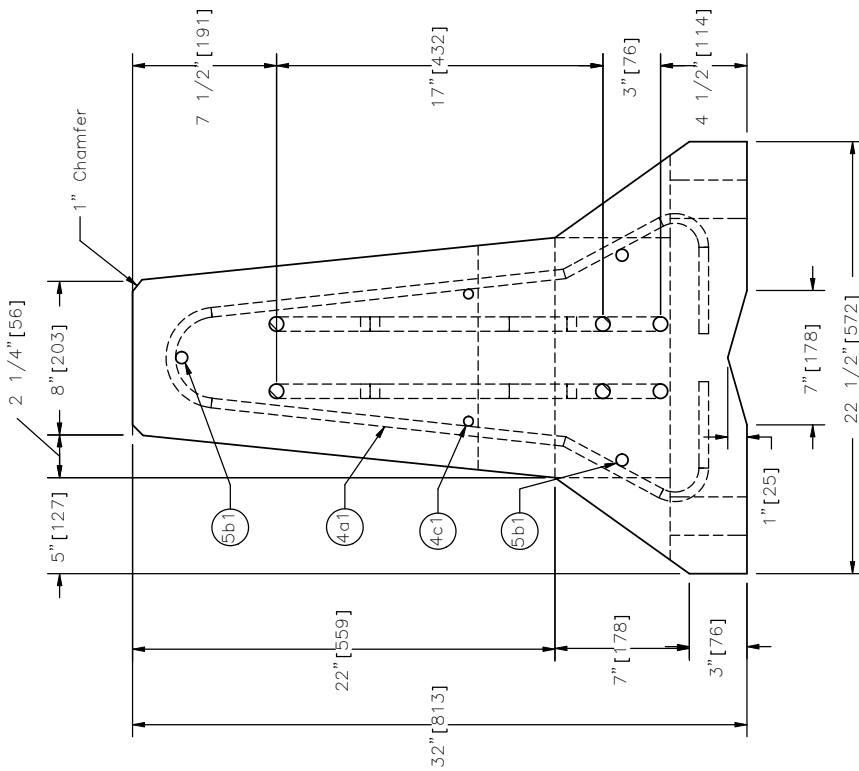

SECTION A-A

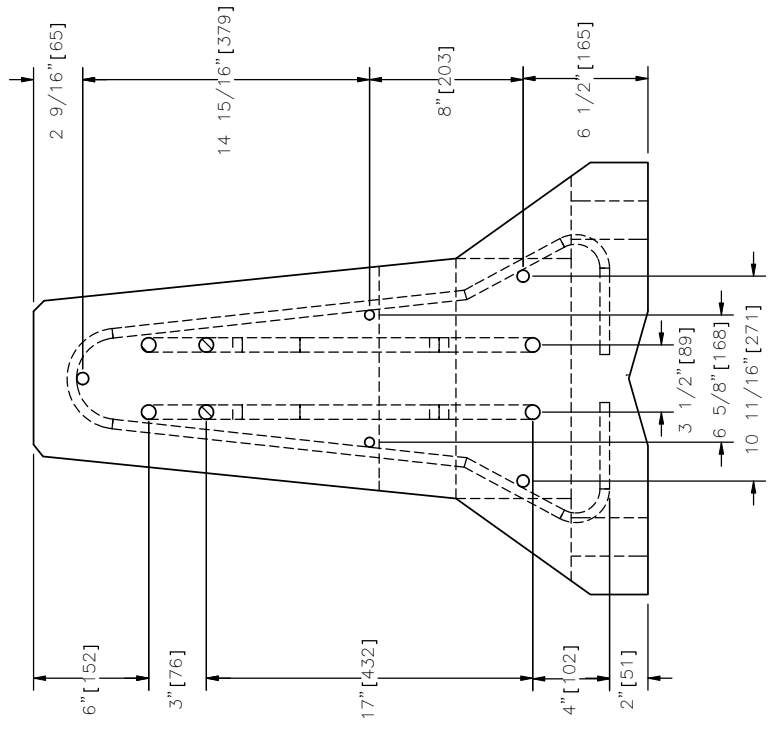

SECTION B-B

PORTABLE F-SHAPE CONCRETE BARRIER ELEMENT



SWC09

SHEET NO.

DATE:

3 of 6

10/29/2008

REFERENCES

Bielenberg, B.W., Faller, R.K., Rohde, J.R., Reid, J.R., Sicking, D.L., and Holloway, J.C., *Development of Tie-Down and Transition Systems for Temporary Concrete Barrier on Asphalt Road Surfaces*. Final Report to the Midwest State's Regional Pooled Fund Program, Transportation Research Report No. TRP-03-180-06, Project No. SPR-3(017), Midwest Roadside Safety Facility, University of Nebraska-Lincoln, February 2007.

Bielenberg, B.W., Faller, R.K., Rohde, J.R., and Sicking, D.L., *Tie-Down and Transitions for Temporary Concrete Barriers*. Paper No. 06-1276, Transportation Research Record No. 1984, Transportation Research Board, National Research Council Washington, D.C., January 2006.

Polivka, K.A., Faller, R.K., Rohde, J.R., Holloway, J.C., Bielenberg, B.W., and Sicking, D.L., *Development and Evaluation of a Tie-Down System for the Redesigned F-Shape Concrete Temporary Barrier*, Final Report to the Midwest State's Regional Pooled Fund Program, Transportation Research Report No. TRP-03-134-03, Project No. SPR-3(017)- Year 13, Project Code: RPPF-03-06, Midwest Roadside Safety Facility, University of Nebraska-Lincoln, August 22, 2003.

Polivka, K.A., Faller, R.K., Sicking, D.L., Rohde, J.R., Bielenberg, B.W., and Reid, J.D., *Performance Evaluation of the Free-Standing Temporary Barrier - Update to NCHRP 350 Test No. 3-11 (2214TB-1)*. Final Report to the National Cooperative Highway Research Program, Transportation Research Report Number TRP-03-173-06, Midwest Roadside Safety Facility, University of Nebraska-Lincoln, October 11, 2006.

Polivka, K.A., Faller, R.K., Sicking, D.L., Rohde, J.R., Bielenberg, B.W., and Reid, J.D., *Performance Evaluation of the Free-Standing Temporary Barrier - Update to NCHRP 350 Test No. 3-11 with 28" C.G. Height (2214TB-2)*. Final Report to the National Cooperative Highway Research Program, Transportation Research Report Number TRP-03-174-06, Midwest Roadside Safety Facility, University of Nebraska-Lincoln, October 12, 2006.

CONTACT INFORMATION

Midwest Roadside Safety Facility
E527 Nebraska Hall
Lincoln, NE 68588-0529
(402) 472-0965
Email: mwrsf@unl.edu
Website: <http://mwrsf.unl.edu/>



PORTABLE F-SHAPE CONCRETE BARRIER ELEMENT

SWC09



SHEET NO.

DATE:

4 of 6

10/29/2008

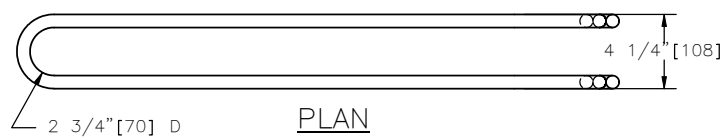
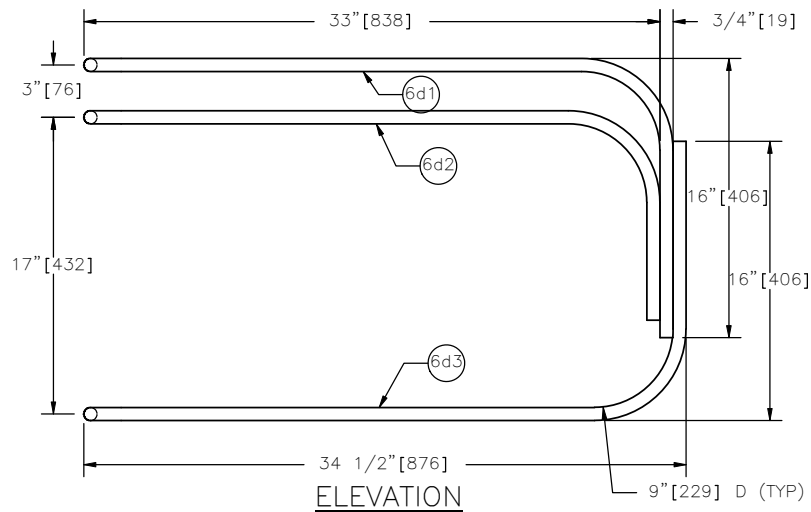
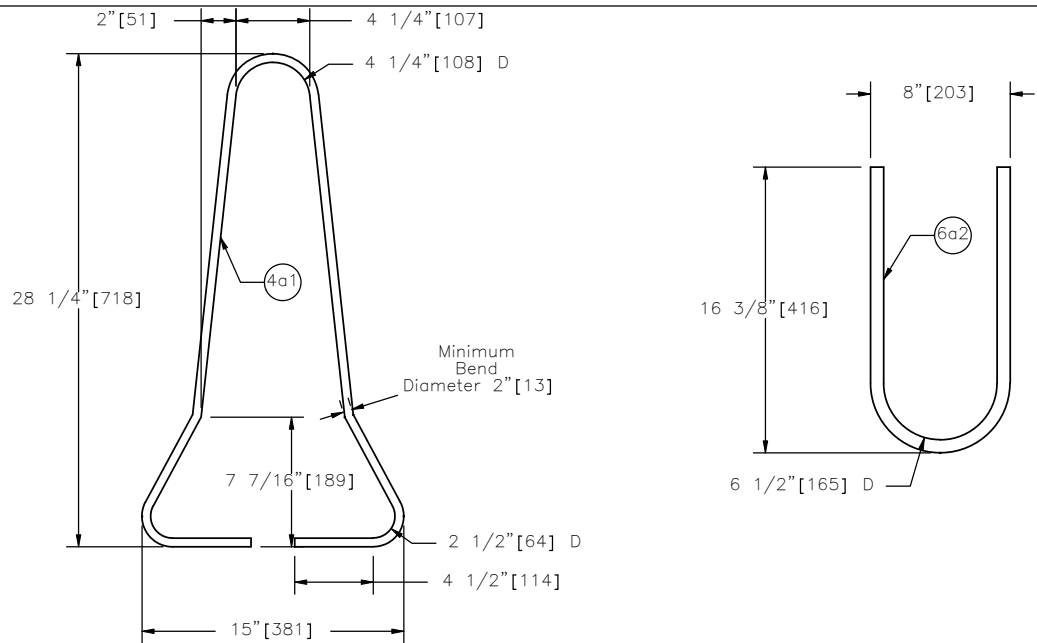

BILL OF MATERIALS					
	Bar No.	No.	Length	Material	
	4a1	4	12	72" [1829]	A615 Gr.60
	4c1	4	2	146" [3708]	A615 Gr.60
	5b1	5	3	146" [3708]	A615 Gr.60
	6a2	6	6	35" [889]	A615 Gr.60
	6d1	6	2	101" [2565]	A709 Gr.70 or A706 Gr.60
	6d2	6	2	91" [2311]	A709 Gr.70 or A706 Gr.60
	6d3	6	2	102" [2591]	A709 Gr.70 or A706 Gr.60

PORTABLE F-SHAPE CONCRETE BARRIER ELEMENT



SWC09

SHEET NO.

DATE:

5 of 6

10/29/2008

LOOP BAR SPECIFICATIONS

The loop bars (6d1, 6d2, and 6d3) shall be 0.75" [19] smooth steel bars with a minimum yield of 60 ksi [420 MPa], a tensile strength of not less than 1.25 times the yield strength but a minimum of 78 ksi [550 MPa], a minimum 14% elongation in 8" [203], and passing a 180 degree bend test using a 3.5D pin bend diameter. The loops shall be installed within 0.12" [3] of the plan dimensions.

PORTABLE F-SHAPE CONCRETE BARRIER ELEMENT

SWC09



SHEET NO.

DATE:

6 of 6

10/29/2008