

Research Project Number SPR-FY21(010)

CRASHWORTHY PERFORATED SQUARE STEEL TUBE (PSST) MAILBOX SUPPORT – PHASE I



Submitted by

Robert W. Bielenberg, M.S.M.E.
Research Associate Engineer

Cody Stolle, Ph.D.
Research Assistant Professor

Ronald K. Faller, Ph.D., P.E.
Professor & MwRSF Director

MIDWEST ROADSIDE SAFETY FACILITY

Nebraska Transportation Center
University of Nebraska-Lincoln

Main Office

Prem S. Paul Research Center at Whittier School
Room 130, 2200 Vine Street
Lincoln, Nebraska 68583-0853
(402)472-0965

Outdoor Test Site

4630 N.W. 36th Street
Lincoln, Nebraska 68524

Submitted to

NEBRASKA DEPARTMENT OF TRANSPORTATION

1500 Nebraska Highway 2
Lincoln, Nebraska 68502

MwRSF Research Report No. TRP-03-473-23

July 24, 2023

TECHNICAL REPORT DOCUMENTATION PAGE

1. Report No. SPR-FY21(010)		2. Government Accession No.		3. Recipient's Catalog No.	
4. Title and Subtitle Crashworthy Perforated Square Steel Tube (PSST) Mailbox Support – Phase I				5. Report Date July 24, 2023	
				6. Performing Organization Code	
7. Author(s) Bielenberg, R.W., Stolle, C.S., and Faller, R.K.				8. Performing Organization Report No. TRP-03-473-23	
9. Performing Organization Name and Address Midwest Roadside Safety Facility (MwRSF) Nebraska Transportation Center University of Nebraska-Lincoln Main Office: Prem S. Paul Research Center at Whittier School Room 130, 2200 Vine Street Lincoln, Nebraska 68583-0853				10. Work Unit No.	
				11. Contract SPR-FY21(010)	
12. Sponsoring Agency Name and Address Nebraska Department of Transportation 1500 Nebraska Highway 2 Lincoln, Nebraska 68502				13. Type of Report and Period Covered Final Report: 2021-2023	
				14. Sponsoring Agency Code SPR-FY21(010)	
15. Supplementary Notes Prepared in cooperation with U.S. Department of Transportation, Federal Highway Administration					
16. Abstract <p>Federal requirements have made it mandatory that safe mailbox support systems be designed to yield or breakaway when impacted by a vehicle. The Nebraska Department of Transportation (NDOT) has previously used a non-proprietary, U-channel post mailbox support that was evaluated at the Midwest Roadside Safety Facility (MwRSF) in the 1980's. NDOT desires that the mailbox support be updated to meet MASH 2016 TL-3 safety performance criteria and be redesigned to use perforated square steel tubing (PSST) for the mailbox support post.</p> <p>The objective of this research project is to develop a non-proprietary mailbox support using PSST support posts that is MASH TL-3 compliant. Following a literature review, single and double PSST mailbox support prototypes were developed. The performance of these prototypes was investigated through dynamic component testing under impact conditions similar to MASH test no. 3-61 with a non-compliant, surrogate 1100C vehicle. Test no. NMB-1 impacted both the single and dual PSST mailbox supports in a single vehicle pass at angles of 0- and 10 degrees, respectively. Both PSST mailbox support options performed adequately in the dynamic testing with no issues observed with respect to occupant risk values or occupant compartment deformation or penetration. Recommendations were made following the testing regarding further research and testing of different mailbox configurations and critical impact angles.</p>					
17. Key Words Highway Safety, Crash Test, Roadside Appurtenances, Dynamic Component Test, MASH 2016, Mailbox			18. Distribution Statement No restrictions. This document is available through the National Technical Information Service. 5285 Port Royal Road Springfield, VA 22161		
19. Security Classification (of this report) Unclassified	20. Security Classification (of this page) Unclassified	21. No. of Pages 144	22. Price		

DISCLAIMER STATEMENT

This material is based upon work supported by the Federal Highway Administration, U.S. Department of Transportation and the Nebraska Department of Transportation under SPR-FY21(010). The contents of this report reflect the views and opinions of the authors who are responsible for the facts and the accuracy of the data presented herein. The contents do not necessarily reflect the official views or policies of the University of Nebraska-Lincoln, Nebraska Department of Transportation, the Federal Highway Administration, nor the U.S. Department of Transportation. This report does not constitute a standard, specification, or regulation. Trade or manufacturers' names, which may appear in this report, are cited only because they are considered essential to the objectives of the report. The United States (U.S.) government and the State of Nebraska do not endorse products or manufacturers.

This report has been reviewed by the Nebraska Transportation Center for grammar and context, formatting, and 508 compliance.

UNCERTAINTY OF MEASUREMENT STATEMENT

The Midwest Roadside Safety Facility (MwRSF) has determined the uncertainty of measurements for several parameters involved in standard full-scale crash testing and non-standard testing of roadside safety features. Information regarding the uncertainty of measurements for critical parameters is available upon request by the sponsor and the Federal Highway Administration. The tests contained within were non-certified component tests conducted for research and development purposes only and are outside the scope of MwRSF's A2LA Accreditation.

ACKNOWLEDGEMENTS

The authors wish to acknowledge several sources that made a contribution to this project: the Nebraska Department of Transportation; and (2) MwRSF personnel for constructing the barriers and conducting the dynamic component tests.

Acknowledgement is also given to the following individuals who contributed to the completion of this research project.

Midwest Roadside Safety Facility

J.C. Holloway, M.S.C.E., Research Engineer & Assistant
Director –Physical Testing Division
K.A. Lechtenberg, M.S.M.E., Research Engineer
S.K. Rosenbaugh, M.S.C.E., Research Engineer
J.S. Steelman, Ph.D., P.E., Associate Professor
M. Asadollahi Pajouh, Ph.D., P.E., Research Assistant
Professor
B.J. Perry, M.E.M.E., Research Associate Engineer
A.T. Russell, B.S.B.A., Testing and Maintenance Technician
II
D.S. Charroin, Engineering Testing Technician II
R.M. Novak, Engineering Testing Technician II
S.M. Tighe, Engineering Testing Technician I
T.C. Donahoo, Engineering Testing Technician I
J.T. Jones, Engineering Testing Technician I
C. Charroin, Temporary Engineering Construction Testing
Technician I

Midwest Roadside Safety Facility, Cont.

T. Shapland, Temporary Engineering Construction Testing
Technician I
E.L. Urbank, B.A., Research Communication Specialist
Z.Z. Jabr, Engineering Technician
Undergraduate and Graduate Research Assistants

Nebraska Department of Transportation

Phil TenHulzen, P.E., Design Standards Engineer
Jim Knott, P.E., Construction Engineer
Mick Syslo, P.E., State Roadway Design Engineer
Brandon Varilek, P.E., Materials and Research Engineer &
Division Head
Mark Fischer, P.E., PMP, Research Program Manager
Lieska Halsey, Research Project Manager
Angela Andersen, Research Coordinator
David T. Hansen, Internal Research Coordinator
Jodi Gibson, Former Research Coordinator

SI* (MODERN METRIC) CONVERSION FACTORS				
APPROXIMATE CONVERSIONS TO SI UNITS				
Symbol	When You Know	Multiply By	To Find	Symbol
LENGTH				
in.	inches	25.4	millimeters	mm
ft	feet	0.305	meters	m
yd	yards	0.914	meters	m
mi	miles	1.61	kilometers	km
AREA				
in ²	square inches	645.2	square millimeters	mm ²
ft ²	square feet	0.093	square meters	m ²
yd ²	square yard	0.836	square meters	m ²
ac	acres	0.405	hectares	ha
mi ²	square miles	2.59	square kilometers	km ²
VOLUME				
fl oz	fluid ounces	29.57	milliliters	mL
gal	gallons	3.785	liters	L
ft ³	cubic feet	0.028	cubic meters	m ³
yd ³	cubic yards	0.765	cubic meters	m ³
NOTE: volumes greater than 1,000 L shall be shown in m ³				
MASS				
oz	ounces	28.35	grams	g
lb	pounds	0.454	kilograms	kg
T	short ton (2,000 lb)	0.907	megagrams (or "metric ton")	Mg (or "t")
TEMPERATURE (exact degrees)				
°F	Fahrenheit	$\frac{5(F-32)}{9}$ or $(F-32)/1.8$	Celsius	°C
ILLUMINATION				
fc	foot-candles	10.76	lux	lx
fl	foot-Lamberts	3.426	candela per square meter	cd/m ²
FORCE & PRESSURE or STRESS				
lbf	poundforce	4.45	newtons	N
lbf/in ²	poundforce per square inch	6.89	kilopascals	kPa
APPROXIMATE CONVERSIONS FROM SI UNITS				
Symbol	When You Know	Multiply By	To Find	Symbol
LENGTH				
mm	millimeters	0.039	inches	in.
m	meters	3.28	feet	ft
m	meters	1.09	yards	yd
km	kilometers	0.621	miles	mi
AREA				
mm ²	square millimeters	0.0016	square inches	in ²
m ²	square meters	10.764	square feet	ft ²
m ²	square meters	1.195	square yard	yd ²
ha	hectares	2.47	acres	ac
km ²	square kilometers	0.386	square miles	mi ²
VOLUME				
mL	milliliter	0.034	fluid ounces	fl oz
L	liters	0.264	gallons	gal
m ³	cubic meters	35.314	cubic feet	ft ³
m ³	cubic meters	1.307	cubic yards	yd ³
MASS				
g	grams	0.035	ounces	oz
kg	kilograms	2.202	pounds	lb
Mg (or "t")	megagrams (or "metric ton")	1.103	short ton (2,000 lb)	T
TEMPERATURE (exact degrees)				
°C	Celsius	1.8C+32	Fahrenheit	°F
ILLUMINATION				
lx	lux	0.0929	foot-candles	fc
cd/m ²	candela per square meter	0.2919	foot-Lamberts	fl
FORCE & PRESSURE or STRESS				
N	newtons	0.225	poundforce	lbf
kPa	kilopascals	0.145	poundforce per square inch	lbf/in ²

*SI is the symbol for the International System of Units. Appropriate rounding should be made to comply with Section 4 of ASTM E380.

TABLE OF CONTENTS

DISCLAIMER STATEMENT ii

UNCERTAINTY OF MEASUREMENT STATEMENT ii

ACKNOWLEDGEMENTS ii

SI* (MODERN METRIC) CONVERSION FACTORS iii

TABLE OF CONTENTS iv

LIST OF FIGURES vi

LIST OF TABLES viii

1 INTRODUCTION 1

 1.1 Objective 1

 1.2 Scope 1

2 LITERATURE REVIEW 3

 2.1 MASH Mailbox Testing 3

 2.1.1 TxDOT Winged-Channel Mailbox Support 3

 2.1.2 TxDOT Double Mailbox System on Thin-Walled Galvanized Tube 7

 2.1.3 TxDOT Large Mailbox on Type 3 Support 10

 2.1.4 TxDOT Large Mailbox on Type 4 Support 15

 2.1.5 Locking Architectural Mailbox on Single Mount Post 18

 2.1.6 Dual Locking Architectural Mailbox on Single Mount Post 24

 2.1.7 Single Mailbox with Recycled Rubber Support Post in a Type 4 Foundation
 30

 2.1.8 Double Mailbox with Thin-Wall Galvanized Support Post in a Type 4
 Foundation 33

 2.1.9 MASH Mailbox Testing Conclusions 36

 2.2 MASH PSST Sign Support Testing 37

 2.3 NDOT Mailbox Rule 37

 2.4 Commercially Available Mailboxes 37

3 DESIGN OF PSST MAILBOX SUPPORT 39

 3.1 Original Proposed NDOT Mailbox Support 39

 3.2 Mailbox Support Design Criteria 41

 3.3 Single Mailbox Support Concept 43

 3.4 Dual Mailbox Support Concept 45

4 TEST REQUIREMENTS AND EVALUATION CRITERIA 48

 4.1 Test Requirements 48

 4.2 Evaluation Criteria 49

 4.3 Soil Strength Requirements 49

- 5 TEST CONDITIONS..... 51
 - 5.1 Test Facility 51
 - 5.2 Vehicle Tow and Guidance System..... 51
 - 5.3 Test Vehicles..... 51
 - 5.4 Simulated Occupant 54
 - 5.5 Data Acquisition Systems 55

- 6 DESIGN DETAILS 57

- 7 COMPONENT TEST NO. NMB-1 (NMB-1A AND NMB-1B) 72
 - 7.1 Weather Conditions 72
 - 7.2 Test Description 72
 - 7.3 System Damage 80
 - 7.4 Vehicle Damage..... 85
 - 7.5 Occupant Risk..... 87
 - 7.6 Discussion 88

- 8 ADDITIONAL TEST ANALYSIS AND DISCUSSION 91

- 9 SUMMARY AND CONCLUSIONS 93

- 10 REFERENCES 95

- 11 APPENDICES 97
 - Appendix A. Commercially Available Mailbox Hardware 98
 - Appendix B. Material Certifications 109
 - Appendix C. Vehicle Center of Gravity Determination..... 124
 - Appendix D. Accelerometer and Rate Transducer Data Plots, Test No. NMB-1 127

LIST OF FIGURES

Figure 1. Original NDOT Breakaway Mailbox Support Design [1]	2
Figure 2. TxDOT Winged-Channel Mailbox Support - Test No. 469467-8-4 [5]	5
Figure 3. TxDOT Winged-Channel Mailbox Support - Test No. 469467-8-4, Test Results [5]....	6
Figure 4. TxDOT Double Mailbox System on Thin-Walled Galvanized Tube - Test No. 469467-8-3 [5]	8
Figure 5. TxDOT Double Mailbox System on Thin-Walled Galvanized Tube - Test No. 469467-8-3, Test Results [5].....	9
Figure 6. TxDOT Large Mailbox on Type 3 Support - Test No. 469689-1-3 [6]	11
Figure 7. TxDOT Large Mailbox on Type 3 Support - Test No. 469689-1-3, Test Results [6]...	12
Figure 8. TxDOT Large Mailbox on Type 3 Support - Test No. 469689-1-4 [6]	13
Figure 9. TxDOT Large Mailbox on Type 3 Support - Test No. 469689-1-4, Test Results [6]...	14
Figure 10. TxDOT Large Mailbox on Type 4 Support - Test No. 469689-1-1 [6]	16
Figure 11. TxDOT Large Mailbox on Type 4 Support - Test No. 469689-1-1, Test Results [6].	17
Figure 12. Locking Architectural Mailbox on Single Mount Post - Test No. 490023-9-1 [7].....	20
Figure 13. Locking Architectural Mailbox on Single Mount Post - Test No. 490023-9-1, Test Results [7]	21
Figure 14. Locking Architectural Mailbox on Single Mount Post - Test No. 490023-9-2, Test Results [7]	23
Figure 15. Locking Architectural Mailbox on Dual Mount Post - Test No. 490023-9-3 [7]	26
Figure 16. Locking Architectural Mailbox on Dual Mount Post - Test No. 490023-9-3, Test Results [7]	27
Figure 17. Locking Architectural Mailbox on Dual Mount Post - Test No. 490023-9-4, Test Results [7]	29
Figure 18. Single Mailbox with Recycled Rubber Support Post in Type 4 Foundation - Test No. 469468-8-1 [8]	31
Figure 19. Single Mailbox with Recycled Rubber Support Post in Type 4 Foundation - Test No. 469468-8-1, Test Results [8].....	32
Figure 20. Double Mailbox with Thin-Wall Galvanized Support Post in Type 4 Foundation - Test No. 469468-8-2 [8]	34
Figure 21. Double Mailbox with Thin-Wall Galvanized Support Post in Type 4 Foundation - Test No. 469468-8-2, Test Results [8].....	35
Figure 22. NDOT Original PSST Mailbox Support Design Concept.....	40
Figure 23. Various Mailbox Mounting Configurations	42
Figure 24. Single Mailbox Support Concept	44
Figure 25. Non-Proprietary Dual Mailbox Support Bracket Concept No. 1	45
Figure 26. Non-Proprietary Dual Mailbox Support Bracket Concept No. 2	45
Figure 27. TAPCO Dual Mailbox Mounting Kit.....	46
Figure 28. Modified TAPCO Dual Mailbox Mount for PSST Mailbox Support	47
Figure 29. Test Vehicle, Test No. NMB-1.....	52
Figure 30. Vehicle Dimensions, Test No. NMB-1	53
Figure 31. Target Geometry, Test No. NMB-1	54
Figure 32. Camera Locations, Speeds, and Lens Settings, Test No. NMB-1	56
Figure 33. Test Installation Layout, Test No. NMB-1	58
Figure 34. Support Layout Details, Test No. NMB-1.....	59
Figure 35. Support Assembly Details, Test No. NMB-1	60

Figure 36. Dual Mailbox Support Assembly Details, Test No. NMB-1..... 61
Figure 37. Configurations 1 and 2 Mailbox Mounting Details, Test No. NMB-1 62
Figure 38. Mailbox Mount Assembly Details, Test No. NMB-1 63
Figure 39. Support Tubes and Mailbox Details, Test No. NMB-1 64
Figure 40. Dual Mailbox Mount Bracket Components, Test No. NMB-1 65
Figure 41. Hardware, Test No. NMB-1 66
Figure 42. Dual Mailbox Mounting Hardware, Test No. NMB-1 67
Figure 43. Bill of Materials, Test No. NMB-1 68
Figure 44. Test Installation Photographs, Test No. NMB-1 69
Figure 45. Test Installation Photographs, Test No. NMB-1 70
Figure 46. Test Installation Photographs, Test No. NMB-1 71
Figure 47. Target Impact Location, Test No. NMB-1 74
Figure 48. Sequential Photographs, Test No. NMB-1 76
Figure 49. Sequential Photographs, Test No. NMB-1A 77
Figure 50. Sequential Photographs, Test No. NMB-1B 78
Figure 51. Vehicle Final Position and Trajectory Marks, Test No. NMB-1 79
Figure 52. System Damage, Test No. NMB-1A..... 81
Figure 53. System Damage, Test No. NMB-1A..... 82
Figure 54. System Damage, Test No. NMB-1B 83
Figure 55. System Damage, Test No. NMB-1B 84
Figure 56. Vehicle Damage Test No. NMB-1 86
Figure 57. Summary of Test Results and Sequential Photographs, Test No. NMB-1A..... 89
Figure 58. Summary of Test Results and Sequential Photographs, Test No. NMB-1B 90

LIST OF TABLES

Table 1. TxDOT Winged-Channel Mailbox Support - Test No. 469467-8-47
Table 2. TxDOT Double Mailbox System on Thin-Walled Galvanized Tube - Test No.
469467-8-310
Table 3. TxDOT Large Mailbox on Type 3 Support - Test No. 469689-1-313
Table 4. TxDOT Large Mailbox on Type 3 Support - Test No. 469689-1-415
Table 5. TxDOT Large Mailbox on Type 4 Support - Test No. 469689-1-118
Table 6. Locking Architectural Mailbox on Single Mount Post - Test No. 490023-9-122
Table 7. Locking Architectural Mailbox on Single Mount Post - Test No. 490023-9-224
Table 8. Locking Architectural Mailbox on Dual Mount Post - Test No. 490023-9-328
Table 9. Locking Architectural Mailbox on Dual Mount Post - Test No. 490023-9-430
Table 10. Single Mailbox with Recycled Rubber Support Post in Type 4 Foundation - Test
No. 469468-8-133
Table 11. Double Mailbox with Thin-Wall Galvanized Support Post in Type 4 Foundation -
Test No. 469468-8-236
Table 12. MASH TL-3 Crash Test Conditions for Support Structures48
Table 13. MASH Evaluation Criteria for Mailboxes50
Table 14. Weather Conditions, Test No. NMB-172
Table 15. Sequential Description of Impact Events, Test No. NMB-1A75
Table 16. Sequential Description of Impact Events, Test No. NMB-1B75
Table 17. Summary of OIV, ORA, THIV, PHD, and ASI Values, Test No. NMB-1A87
Table 18. Summary of OIV, ORA, THIV, PHD, and ASI Values, Test No. NMB-1B88
Table B-1. Bill of Materials, NMB-1110

1 INTRODUCTION

Federal requirements have made it mandatory that safe mailbox support systems be designed to yield or break away when impacted by a vehicle. The Nebraska Department of Transportation (NDOT) has previously used a non-proprietary, U-channel post mailbox support that was evaluated at the Midwest Roadside Safety Facility (MwRSF) in the 1980s, as shown in Figure 1 [1]. This design was successfully evaluated according to National Cooperative Highway Research Program (NCHRP) *Report 230* [2] and the American Association of State Highway and Transportation Officials (AASHTO) *Standard Specifications for Structural Supports for Highway Signs, Luminaires and Traffic Signals* [3] with a small car vehicle in weak and strong soils as well as at 20-mph and 60-mph speeds. Single and double mailbox configurations were also evaluated. This design was implemented into NDOT's standard plans. However, this standard plan is now obsolete.

NDOT desired that the mailbox support be updated to meet *Manual for Assessing Safety Hardware* (MASH) [4] Test Level 3 (TL-3) safety performance criteria due to the limited number of mailbox supports that have been evaluated to these specifications. Additionally, NDOT preferred to use perforated square steel tubing (PSST) for the mailbox support post to be consistent with their sign supports. To accommodate NDOT desires, the existing mailbox mount needed to be redesigned, and the breakaway performance of the PSST needed to be evaluated in combination with the desired mailbox configurations. The design would consider single and multiple mailbox configurations, as desired by NDOT. Development of a PSST mailbox support that meets MASH TL-3 requirements would provide NDOT with a crashworthy solution for mailboxes adjacent to state roadways. Additionally, the adoption of a design using PSST similar to current NDOT sign supports would reduce and simplify the state inventory.

1.1 Objective

The objective of this research project was to develop a non-proprietary mailbox support using PSST support posts that are MASH TL-3 compliant. The design considered single and multiple mailbox configurations. The design started with an existing, proposed NDOT mailbox support and was modified based on review of existing designs and potential mailbox configurations. The Phase I objective was to design and evaluate the mailbox support utilizing bogie testing.

1.2 Scope

The research effort to develop a MASH TL-3 crashworthy, non-proprietary mailbox support using PSST support posts began with a literature search to review previously conducted relevant research. Following the literature search, MwRSF reviewed the collected mailbox and sign support information and synthesized existing designs. This information was used to establish design criteria for a new mailbox support based on NDOT's needs. MwRSF then developed and proposed new mailbox support designs with NDOT feedback. Candidate designs were evaluated through dynamic component testing and recommendations were made regarding the performance of the designs.

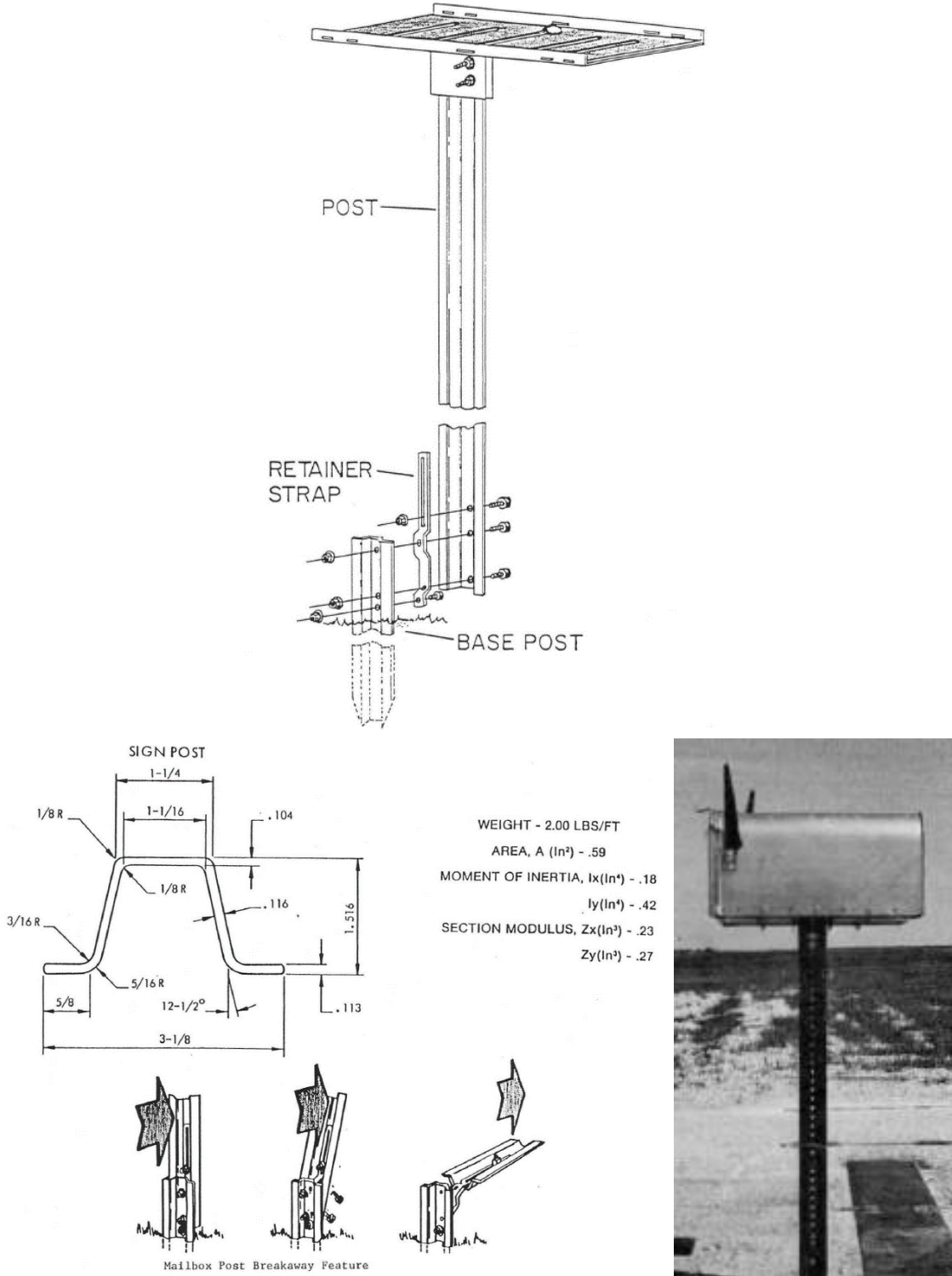

Figure 1. Original NDOT Breakaway Mailbox Support Design [1]

2 LITERATURE REVIEW

The first step in the design of a PSST mailbox support was to review relevant, existing research regarding mailbox testing and PSST sign support testing. MwRSF also reviewed NDOT's current standard practices with regard to mailbox supports along with currently available mailboxes to determine the potential range of mailbox sizes and masses for consideration in the study. Details on these items are contained in the subsequent sections.

2.1 MASH Mailbox Testing

The researchers collected 48 mailbox crash test results. Several of those crash tests involved older test evaluation criteria and vehicle types. As the research effort herein was focused on development of a MASH-compliant PSST mailbox support, the literature review focused on MASH crash-tested mailbox systems. Additionally, some of the MASH evaluated mailbox systems involved more than two mailboxes on a single support. These were deemed not relevant to the current study as NDOT was only considering single and dual mailboxes on a single support. The existing MASH tests were reviewed to discover the types of mailboxes and supports that have been tested to date, to determine design factors influencing the performance of the mailbox supports, and to identify critical crash tests within the MASH test matrix. Brief summaries of the relevant MASH mailbox testing are provided in the subsequent sections.

2.1.1 TxDOT Winged-Channel Mailbox Support

Texas A&M Transportation Institute (TTI) evaluated a dual mailbox support consisting of two mailboxes attached to a 2-lb/ft winged channel post directly embedded in soil under MASH TL-3 safety criteria [5], as shown in Figure 2. Two Elite No. 1-A standard arched-top mailboxes (Gibraltar Industries Model #E1600B00) were attached to the top of the support post. Each Elite mailbox was approximately 11 in. tall \times 8 $\frac{3}{4}$ in. wide \times 21 $\frac{1}{2}$ in. deep and weighed 7 lb. Attachment of each Elite mailbox to the post was accomplished using a mailbox bracket (DHT #148939), one extension bracket (DHT #148938), and associated SAE Grade 5 bolts, nuts, and washers. The mailboxes, located 10 $\frac{1}{4}$ in. center to center, were secured to a bracket plate (DHT #3789) that was attached to the support post using a two-part angle bracket. Angle bracket Part "A" (DHT #159489) was located on the outside of the rib of the wing channel post and angle bracket Part "B" (DHT #159490) was positioned inside the wing channel post on the opposite side. The angle bracket parts were connected to the post using two $\frac{5}{16}$ -in. diameter \times 2 $\frac{3}{4}$ -in. long SAE Grade 5 hex bolts, flat and lock washers, and nuts. Each mailbox was empty, and the bottom of each mailbox was mounted 42 in. above grade.

The two mailboxes were supported on a Texas Department of Transportation (TxDOT) 2-lb/ft steel perforated winged-channel post (DHT #4289) fabricated from ASTM A1011 structural Grade 50 steel. The winged-channel post had an overall length of 71 $\frac{1}{2}$ in. and weighed 12.2 lb. The support post was inserted 30 $\frac{1}{2}$ in. into a drilled hole that measured approximately 12 in. in diameter \times 30 $\frac{1}{2}$ in. deep, which was then backfilled and compacted at the test site. The total mass of the two mailboxes, connection hardware, and support post assembly was 33.2 lb.

The mailbox system was evaluated using MASH test designation no. 3-61, which consisted of a 2,420-lb 1100C small car vehicle impacting the mailbox system at an impact speed of 62 mph and an angle of 0 degrees with a $\frac{1}{4}$ vehicle offset. In test no. 469467-8-4, the 1100C vehicle

impacted the mailbox at a speed of 63.3 mph and an angle of 0 degrees. Following initial impact, the support post deformed about the front bumper of the vehicle, which caused the mailbox to be pulled down onto the vehicle's hood. As the vehicle proceeded downstream, the support post fractured near the ground line, and the support post and mailbox were propelled up and over the top of the vehicle. The mailbox remained attached to the support post throughout the impact. The test was deemed acceptable according to the MASH criteria as all occupant risk criteria and occupant compartment deformation and penetration criteria were met during the test. Post test photographs and sequential images of the test are shown in Figure 3. A summary of the relevant test results is shown in Table 1.



Mail Box	Mailbox Attachment	Mailbox-to-Post Bracket	Support Base	Support Post	Base-to-Post Attachment
<ul style="list-style-type: none"> • Dual Mailbox • Elite No. 1-A mailbox (#E1600B00) • 11 in. tall x 8 3/4 in. wide x 21 1/2 in. deep • Steel • 7 lb (21 lb for mailboxes and bracket) • 42- in. mounting height 	<ul style="list-style-type: none"> • Bracket to Post – two 5/16 – in. diameter SAE Grade 5 bolts • Angle bracket to bracket plate – two 3/8- in. diameter SAE Grade 5 Bolts • Bracket plate to bracket mount and mailbox – four 3/8- in. diameter SAE grade 5 bolts • Extension bracket to bracket mount and mailbox six 1/4- in. bolts per unit 	<ul style="list-style-type: none"> • Bracket mount DHT#148939 • Extension bracket DHT#148938 • Bracket plate DHT#3789 • Angle bracket DHT#159490 	None	<ul style="list-style-type: none"> • 2 lb/ft steel perforated winged-channel post (DHT #4289) fabricated from ASTM A1011 structural Grade 50 	Continuous post with 30 1/2- in. embedment

Figure 2. TxDOT Winged-Channel Mailbox Support - Test No. 469467-8-4 [5]



Figure 3. TxDOT Winged-Channel Mailbox Support - Test No. 469467-8-4, Test Results [5]

Table 1. TxDOT Winged-Channel Mailbox Support - Test No. 469467-8-4

Test No.	469467-8-4
Test Designation	3-61
Test Vehicle	1100C
Impact Speed (mph)	63.3
Vehicle Orientation	¼ Offset
Longitudinal OIV/ Change in Velocity (ft/s)	NA < 16 ft/s
Longitudinal ORA (g's)	NA
Mailbox Release Time (sec)	No mailbox release
Post Release Time (sec)	0.009
Test Result	Pass

2.1.2 TxDOT Double Mailbox System on Thin-Walled Galvanized Tube

TTI conducted MASH TL-3 crash testing on two mailboxes attached to a galvanized thin-wall steel tube support secured inside a 12-gauge galvanized anchor socket embedded in a concrete footing with a curved steel plate wedge, as shown in Figure 4 [5]. Two Elite No. 1-A standard arched-top mailboxes, Gibraltar Industries Model #E1600B00, were attached to the top of the support post. The Elite mailbox had approximate dimensions of 11 in. tall × 8¾ in. wide × 21½ in. deep and weighed 7 lb. Attachment of each mailbox to the post was accomplished using a mailbox bracket (DHT #148939), one extension bracket (DHT #148938), and associated SAE Grade 5 bolts, nuts, and washers. The mailboxes, located 10 in. center to center, were secured plate and collar bracket (DHT #162323) that was attached to the support post using a ⅜-in. diameter × 3½-in. long SAE Grade 5 hex bolt, flat and lock washers, and nut.

The two mailboxes were supported on a nominal 2-in. diameter × 16-gauge thick (2⅜-in. outside diameter × 0.065-in. wall thickness) galvanized thin-wall steel tube (DHT #143426) formed from ASTM A513 Type 5 DOM steel tubing. The overall length of the support post was 57 in. The support post was inserted approximately 15 in. into a socket (DHT #143434) and secured with a wedge (DHT #143433) on the impact side. The socket was embedded 27 in. deep and installed flush with the top of a TxDOT Type 2 non-reinforced concrete footer that measured approximately 12 in. in diameter × 30 in. deep.

The mailbox system was evaluated using MASH test designation no. 3-61, which consisted of a 2,420-lb 1100C small car vehicle impacting the mailbox system at an impact speed of 62 mph and an angle of 0 degrees with a ¼ vehicle offset. In test no. 469467-8-3, the test vehicle impacted the mailbox system at 62.5 mph and an angle of 0 degrees. Following initial impact, the support post deformed about the front bumper of the vehicle, which caused the mailbox to be pulled down onto the vehicle's hood. As the vehicle proceeded downstream, the support post fractured near the ground line, and the support post and mailbox were propelled forward. The mailbox remained attached to the support post throughout the impact. The test was deemed acceptable according to the MASH criteria as all occupant risk criteria and occupant compartment deformation and penetration criteria were met during the test. Post test photo photographs and sequential images of the test are shown in Table 2. A summary of the relevant test results is shown in Figure 5.



Mail Box	Mailbox Attachment	Mailbox-to-Post Bracket	Support Base	Support Post	Base-to-Post Attachment
<ul style="list-style-type: none"> • Dual Mailbox • Elite No. 1-A mailbox (#E1600B00) • 11 in. tall x 8 ¾ in. wide x 21½ in. deep • Steel • 7 lb (20 lb for mailboxes and bracket) • 42-in. mounting height 	<ul style="list-style-type: none"> • Bracket to Post – two 5/16-in. diameter SAE Grade 5 bolts • Angle bracket to bracket plate – two 3/8-in. diameter SAE Grade 5 Bolts • Bracket plate to bracket mount and mailbox – four 3/8-in. diameter SAE grade 5 bolts • Extension bracket to bracket mount and mailbox six 1/4-in. bolts per unit 	<ul style="list-style-type: none"> • Bracket mount DHT#148939 • Extension bracket DHT#148938 • Collar bracket DHT#162323 	Plastic in reinforced concrete footing (12 in. in diameter x 30 in. deep)	<ul style="list-style-type: none"> • 2⅝-in. outside diameter 16 gauge thick • ASTM A513 Type5 DOM • 57 in. long • 7.5 lb 	Socketed with locking wedge and 15-in. embedment

Figure 4. TxDOT Double Mailbox System on Thin-Walled Galvanized Tube - Test No. 469467-8-3 [5]

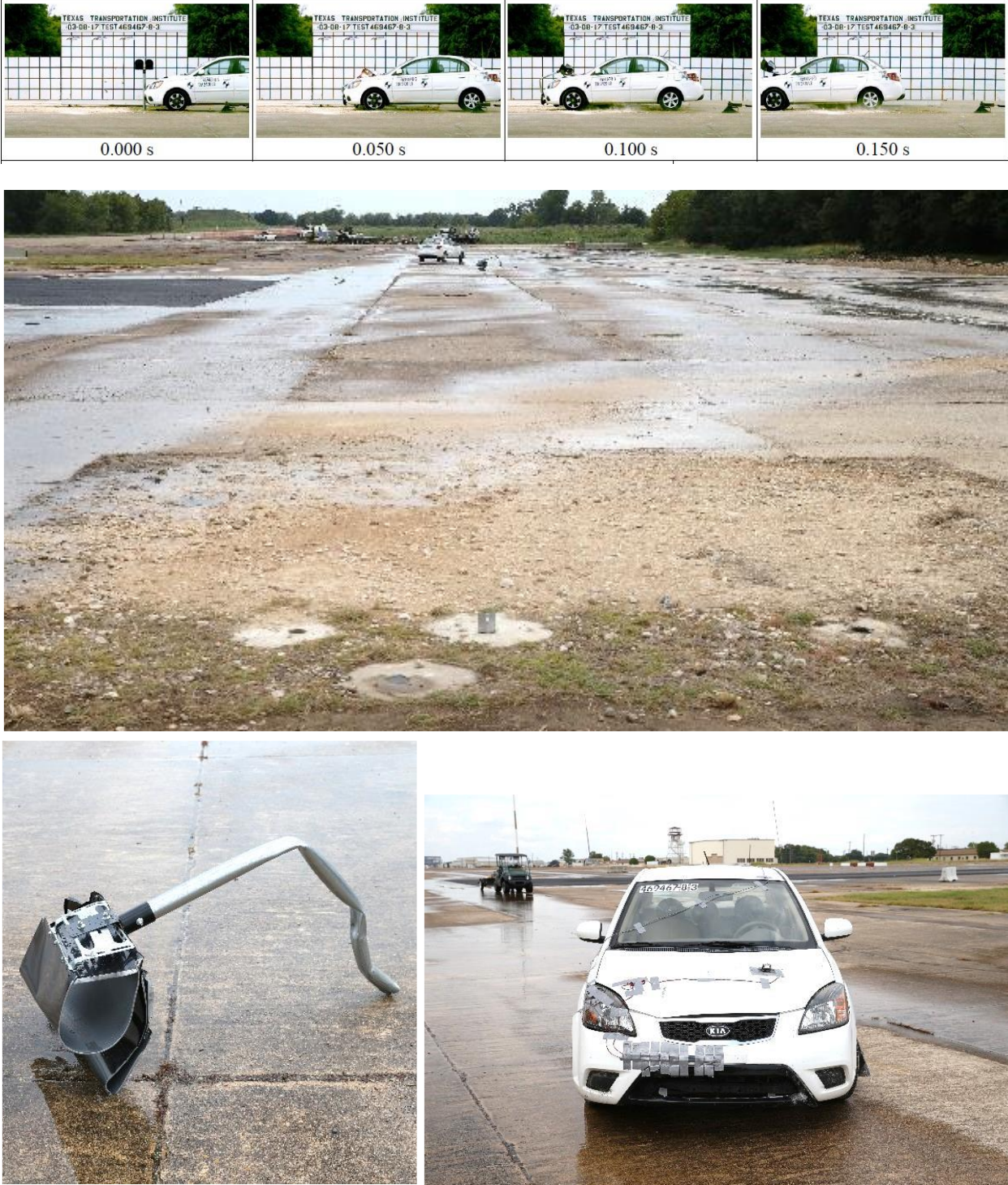

Figure 5. TxDOT Double Mailbox System on Thin-Walled Galvanized Tube - Test No. 469467-8-3, Test Results [5]

Table 2. TxDOT Double Mailbox System on Thin-Walled Galvanized Tube - Test No. 469467-8-3

Test No.	469467-8-3
Test Designation	3-61
Test Vehicle	1100C
Impact Speed (mph)	62.5
Vehicle Orientation	¼ Offset
Longitudinal OIV/ Change in Velocity (ft/s)	NA < 16 ft/s
Longitudinal ORA (g's)	NA
Mailbox Release Time (sec)	No mailbox release
Post Release Time (sec)	0.023
Test Result	Pass

2.1.3 TxDOT Large Mailbox on Type 3 Support

TTI conducted MASH TL-3 crash testing on a single large mailbox mounted on a 2-lb/ft U-channel post, as shown in Figure 6 [6]. A single Architectural Mailboxes® Centennial model #950020B extra-large mailbox was mounted on a 2-lb/ft perforated U-channel post. The mailbox was attached to the post via angle brackets using a model DHT #148939 mailbox bracket. Two steel plate washers measuring 2 in. × 5½ in. × ⅛ in. thick and four 5/16-in. diameter hex bolts secured the bracket assembly to the floor of the mailbox. The post was embedded 30 in. into the soil. The bottom of the mailbox was located 42 in. above grade.

The mailbox system was evaluated using MASH test designation no. 3-61, which consisted of a 2,420-lb 1100C small car vehicle impacting the mailbox system at an impact speed of 62 mph and an angle of 0 degrees with a ¼ vehicle offset. In test no. 469689-1-3, the test vehicle impacted the mailbox system at 63.9 mph and an angle of 0 degrees. Following initial impact, the support post of the mailbox deformed about the front bumper of the vehicle which caused the mailbox to be pulled down onto the hood of the vehicle. As the vehicle proceeded downstream, the support post was pulled from the ground. The upper section of the mailbox detached from its base which remained attached to the support post. The detached upper section of the mailbox then impacted the windshield, causing 4.6 in. of deformation to the windshield and creating a tear in the windshield lining. The test was deemed unacceptable according to the MASH criteria due to the windshield damage observed during the test. Post test photographs and sequential images of the test are shown in Figure 7. A summary of the relevant test results is shown in Table 3.

Following the failure observed in test no. 469689-1-3, TTI modified the mailbox-to-support post attachment with the addition of four slotted L brackets measuring 2 in. × 6 in. × ⅞ in. × ⅛ in thick. The L-brackets allowed for attachment using four additional ¼-in. diameter hex bolts on the side flanges of the mailbox, as shown in Figure 8. TTI conducted a repeat test using the modified version of the single large mailbox mounted on a 2-lb/ft U-channel post. In test no. 469689-1-4, the test vehicle impacted the mailbox system at 63.9 mph and an angle of 0 degrees. Following initial impact, the support post deformed about the front bumper of the vehicle, which caused the mailbox to be pulled down onto the vehicle’s hood. As the vehicle proceeded downstream, the support post was pulled from the ground. The mailbox remained attached to the

support post and was eventually propelled up and over the vehicle. The test was deemed acceptable according to the MASH criteria as all occupant risk criteria and occupant compartment deformation and penetration criteria were met during the test. Post test photographs and sequential images of the test are shown in Figure 9. A summary of the relevant test results is shown in Table 4.



Mail Box	Mailbox Attachment	Mailbox-to-Post Bracket	Support Base	Support Post	Base-to-Post Attachment
<ul style="list-style-type: none"> • Single Mailbox • Architectural Mailboxes© Centennial model #950020B • Steel • 11.8 lb • 42-in. mounting height 	<ul style="list-style-type: none"> • Angle bracket to post – two ⁵/₁₆-in. diameter SAE Grade 5 Bolts • Angle bracket to bracket mount - two ³/₈-in. diameter SAE grade 5 bolts • Bracket mount and mailbox four ⁵/₁₆-in. diameter SAE Grade 5 bolts and plate washers 	<ul style="list-style-type: none"> • Bracket mount DHT# 148939 • Angle bracket DHT# 159489 	<p>none</p>	<ul style="list-style-type: none"> • 2 lb/ft steel perforated U-channel post (DHT #4289) fabricated from ASTM A1011 structural Grade 50 	<p>30-in. embedment</p>

Figure 6. TxDOT Large Mailbox on Type 3 Support - Test No. 469689-1-3 [6]



Figure 7. TxDOT Large Mailbox on Type 3 Support - Test No. 469689-1-3, Test Results [6]

Table 3. TxDOT Large Mailbox on Type 3 Support - Test No. 469689-1-3

Test no.	469689-1-3
Test Designation	3-61
Test Vehicle	1100C
Impact Speed (mph)	63.9
Vehicle Orientation	¼ Offset
Longitudinal OIV/ Change in Velocity (ft/s)	NA < 16 ft/s
Longitudinal ORA (g's)	NA
Mailbox Release Time (sec)	mailbox releases, but no time given
Post Release Time (sec)	0.018
Test Result	Fail – windshield deformation

Connection Details

Plate Washer details from TxDOT
MB-15(1) Drawing, sheet 2

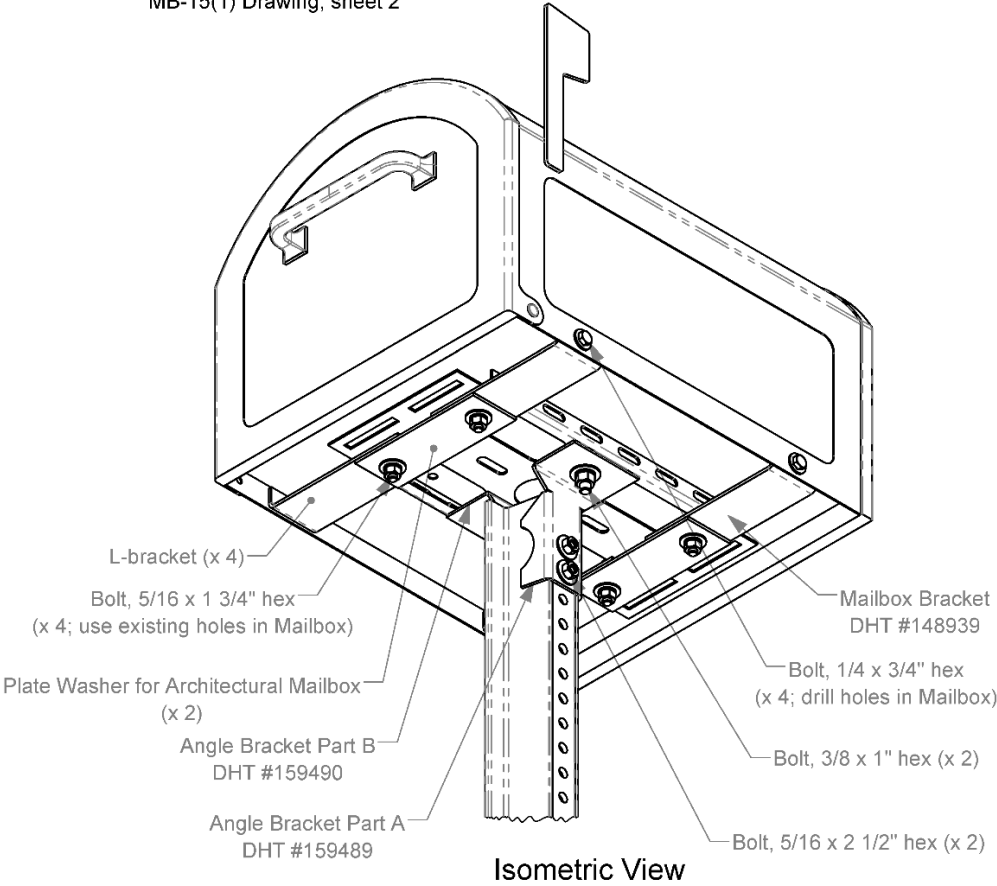

Figure 8. TxDOT Large Mailbox on Type 3 Support - Test No. 469689-1-4 [6]



Figure 9. TxDOT Large Mailbox on Type 3 Support - Test No. 469689-1-4, Test Results [6]

Table 4. TxDOT Large Mailbox on Type 3 Support - Test No. 469689-1-4

Test no.	469689-1-4
Test Designation	3-61
Test Vehicle	1100C
Impact Speed (mph)	63.3
Vehicle Orientation	¼ Offset
Longitudinal OIV/ Change in Velocity (ft/s)	0.3 ft/s < 16 ft/s
Longitudinal ORA (g's)	0.3
Mailbox Release Time (sec)	No mailbox release
Post Release Time (sec)	0.018
Test Result	Pass

2.1.4 TxDOT Large Mailbox on Type 4 Support

TTI conducted MASH TL-3 crash testing of a single large mailbox mounted on a 2-lb/ft u-channel post, as shown in Figure 10 [6]. A single Architectural Mailboxes© Centennial model #950020B extra-large mailbox was mounted on a 2³/₈-in. diameter × 0.095-in. thick steel tube post. The mailbox was attached to the post using a model DHT #161443 mailbox bracket. Two steel plate washers measuring 2 in. × 5½ in. × ⅛-in. thick and four ⁵/₁₆-in. diameter hex bolts that secured the bracket assembly to the floor of the mailbox, and a ⁵/₁₆-in. bolt secured the bracket to the post. The post was inserted into a plastic socket and secured with a plastic wedge. This wedge socket was set in a non-reinforced cylindrical concrete foundation measuring 12 in. in diameter × 30 in. deep. The bottom of the mailbox was located 42 in. above grade.

The mailbox system was evaluated using MASH test designation no. 3-61, which consisted of a 2,420-lb 1100C small car vehicle impacting the mailbox system at an impact speed of 62 mph and an angle of 0 degrees with a ¼ vehicle offset. In test no. 469689-1-1, the test vehicle impacted the mailbox system at a speed of 63.6 mph and an angle of 0 degrees. Following initial impact, the support post deformed about the front bumper of the vehicle, which caused the mailbox to be pulled down onto the hood of the vehicle. The mailbox detached from the support post after contacting the hood and was propelled up and over the vehicle. As the vehicle proceeded downstream, the support was pulled out of its base at the ground line and pushed in front of the vehicle. The test was deemed acceptable according to the MASH criteria as all occupant risk criteria and occupant compartment deformation and penetration criteria were met during the test. Post test photographs and sequential images of the test are shown in Figure 11. A summary of the relevant test results is shown in Table 5.



Mail Box	Mailbox Attachment	Mailbox-to-Post Bracket	Support Base	Support Post	Base-to-Post Attachment
<ul style="list-style-type: none"> • Single Mailbox • Architectural Mailboxes© Centennial model #950020B • Steel • 11.8 lb • 42-in. mounting height 	<ul style="list-style-type: none"> • Bracket to post – one 5/16-in. diameter SAE Grade 5 bolts • Bracket mount and mailbox four 5/16-in. diameter SAE Grade 5 bolts 	<ul style="list-style-type: none"> • Bracket mount DHT# 161443 	Plastic socket in reinforced concrete footing (12 in. in diameter x 30 in. deep)	<ul style="list-style-type: none"> • 2 3/8-in. outside diameter x 0.095-in. thick • DHT#162991 • 54.5 in. long 	Socketed with locking wedge and 12.5-in. embedment

Figure 10. TxDOT Large Mailbox on Type 4 Support - Test No. 469689-1-1 [6]



Figure 11. TxDOT Large Mailbox on Type 4 Support - Test No. 469689-1-1, Test Results [6]

Table 5. TxDOT Large Mailbox on Type 4 Support - Test No. 469689-1-1

Test No.	469689-1-1
Test Designation	3-61
Test Vehicle	1100C
Impact Speed (mph)	63.6
Vehicle Orientation	¼ Offset
Longitudinal OIV/ Change in Velocity (ft/s)	2.0 ft/s < 16ft/s
Longitudinal ORA (g's)	0.8
Mailbox Release Time (sec)	0.025
Post Release Time (sec)	NA
Test Result	Pass

2.1.5 Locking Architectural Mailbox on Single Mount Post

TTI conducted MASH TL-3 crash testing on a single, locking architectural mailbox mounted on a single 2.375-in. outside diameter (OD) thin-wall steel tube (DHT #162911), which was installed in a plastic socket (DHT #160891) that was embedded in a concrete footing, as shown in Figure 12 [7]. The mailbox tested was an Oasis Jr manufactured by Architectural Mailboxes, LLC. It was fabricated from 16-gauge and 14-gauge galvanized steel and had a black powder-coat finish. The mailbox was 15 in. tall × 11½ in. wide × 18 in. deep and weighed 22.6 lb.

A bracket (DHT #161443) weighing approximately 1.8 lb was attached to the bottom of the locking mailbox using four ⅜-in. diameter × 1¼-in. long SAE Grade 5 bolts using existing holes in the mailbox and bracket. A 2-in. wide × 5½-in. long × ⅛-in. thick plate washer was positioned over the bracket to help secure each set of two bolts toward the front and back of the mailbox. The collar of the mailbox bracket (DHT #161443) was secured to the support post using a ⅝-in. × 3-in. long SAE Grade 5 bolt and ⅝-in. hex nut. The mailbox support post was a SHUR-TITE® Products single mailbox post (DHT #162911) fabricated from a 2-in. nominal, 13-gauge, galvanized steel tube with a white powder coat. The support post was installed with a SHUR-TITE® Products plastic wedge anchor system. The socket (DHT #160891) was 3½ in. OD × 7/16 in. wall thickness × 17 in. long. The socket was embedded in a non-reinforced concrete footing that was approximately 12 in. in diameter × 24 in. deep.

The mailbox system was evaluated using MASH test designation no. 3-60 , which consisted of a 2,420-lb 1100C small car vehicle impacting the mailbox system at an impact speed of 19 mph and an angle of 0 degrees with a ¼ vehicle offset; and test designation no. 3-61, which consisted of a 2,420-lb 1100C small car vehicle impacting the mailbox system at an impact speed of 62 mph and an angle of 0 degrees with a ¼ vehicle offset. In test no. 490023-9-1 (test designation no. 3-60), the test vehicle impacted the mailbox system at 19.2 mph and an angle of 0 degrees. Following initial impact, the support post bent downward in front of the vehicle, which allowed the vehicle to override the post and mailbox. The mailbox detached from the support post as the assembly was overridden. The test was deemed acceptable according to the MASH criteria as all occupant risk criteria and occupant compartment deformation and penetration criteria were met during the test. Post test photographs and sequential images of the test are shown in Figure 13. A summary of the relevant test results is shown in Table 6.

In test no. 490023-9-2 (test designation no. 3-61), the test vehicle impacted the mailbox system at 63.8 mph and an angle of 0 degrees. Following initial impact, the support post deformed about the front bumper of the vehicle, which caused the mailbox to be pulled down onto the vehicle's hood. The support post detached from the socket and was propelled downstream. The mailbox remained attached to the support post. The test was deemed acceptable according to the MASH criteria as all occupant risk criteria and occupant compartment deformation and penetration criteria were met during the test. Post test photographs and sequential images of the test are shown in Figure 14. A summary of the relevant test results is shown in Table 7.



Mail Box	Mailbox Attachment	Mailbox-to-Post Bracket	Support Base	Support Post	Base-to-Post Attachment
<ul style="list-style-type: none"> • Single Mailbox • 15 in. tall x 11½ in. wide x 18 in. deep • 16-gauge and 14-gauge steel • 22.6 lb • 42-in. mounting height 	<ul style="list-style-type: none"> • Four ¾-in. diameter SAE Grade 5 bolts • ½-in. plate washer 	<ul style="list-style-type: none"> • Bracket DHT# 161443 	<ul style="list-style-type: none"> • Plastic socket in reinforced concrete footing (12 in. in diameter x 24 in. deep) 	<ul style="list-style-type: none"> • SHUR-TITE® mailbox post • 2⅝-in. outside diameter x 0.095-in. thick steel tube 	<ul style="list-style-type: none"> • Socketed with locking wedge and 12.5-in. embedment

Figure 12. Locking Architectural Mailbox on Single Mount Post - Test No. 490023-9-1 [7]

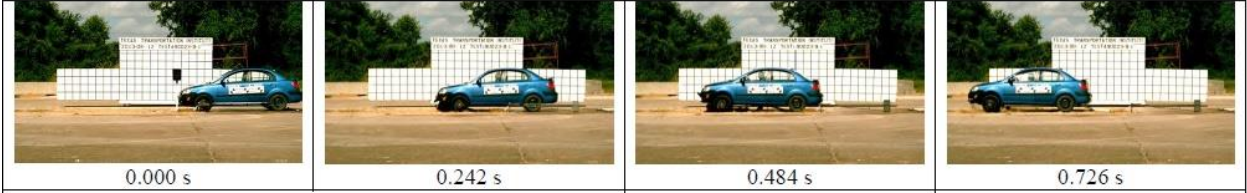

Figure 13. Locking Architectural Mailbox on Single Mount Post - Test No. 490023-9-1, Test Results [7]

Table 6. Locking Architectural Mailbox on Single Mount Post - Test No. 490023-9-1

Test no.	490023-9-1
Test Designation	3-60
Test Vehicle	1100C
Impact Speed (mph)	19.2
Vehicle Orientation	Centerline
Longitudinal OIV/ Change in Velocity (ft/s)	6.9 ft/s < 16 ft/s
Longitudinal ORA (g's)	1.9
Mailbox Release Time (sec)	0.346
Post Release Time (sec)	No post release
Test Result	Pass

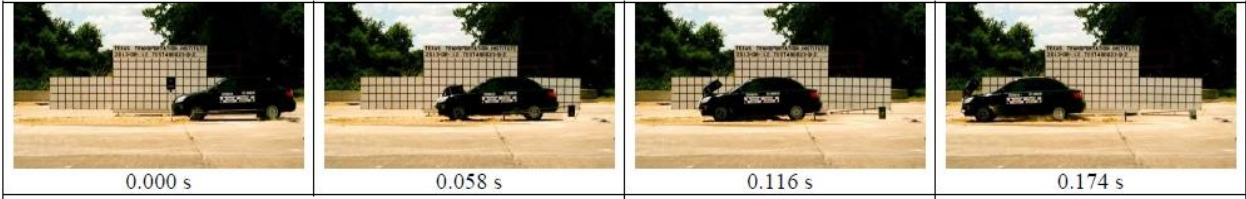

Figure 14. Locking Architectural Mailbox on Single Mount Post - Test No. 490023-9-2, Test Results [7]

Table 7. Locking Architectural Mailbox on Single Mount Post - Test No. 490023-9-2

Test no.	490023-9-2
Test Designation	3-61
Test Vehicle	1100C
Impact Speed (mph)	63.8
Vehicle Orientation	Centerline
Longitudinal OIV/ Change in Velocity (ft/s)	4.9 ft/s < 16 ft/s
Longitudinal ORA (g's)	1.0
Mailbox Release Time (sec)	No mailbox release
Post Release Time (sec)	0.042
Test Result	Pass

2.1.6 Dual Locking Architectural Mailbox on Single Mount Post

TTI conducted MASH TL-3 crash testing of a dual, locking architectural mailbox mounted on a SHUR-TITE® Products multiple mailbox post (DHT #164116) installed in a concrete footing using a plastic socket (DHT #160891) and wedge (DHT #160892), as shown Figure 15 [7]. The mailbox tested was an Oasis Jr. manufactured by Architectural Mailboxes, LLC. It was fabricated from 16-gauge and 14-gauge galvanized steel and had a black powder-coat finish. The mailbox was 15 in. tall × 11½ in. wide × 18 in. deep and weighed 22.6 lb.

A bracket (DHT #161443) weighing approximately 1.8 lb was attached to the bottom of the locking mailbox using four ¾-in. diameter × 1¼-in. long SAE Grade 5 bolts using existing holes in the mailbox and bracket. A 2-in. wide × 5½-in. long × ⅛-in. thick plate washer was positioned over the bracket to help secure each set of two bolts toward the front and back of the mailbox. The mailbox support post was a SHUR-TITE® Products Multiple Mailbox Support (DHT #164116). The support was made up of a semi-circular tube with a 25-in. centerline radius and horizontal cross member fabricated from 2⅜-in. diameter × 0.065-in. thick galvanized steel tube with a white powder coat. The ends of the semi-circular tube were designed to accept mailbox attachments. Two additional intermediate thin-wall steel tube stubs were vertically welded to the horizontal cross member to accept two additional mailboxes. A 22½-in. long thin-wall steel tube was vertically welded at the bottom center of the semi-circular steel tube. The vertical steel tube at the bottom of the support was installed with a SHUR-TITE® Products plastic wedge anchor system. The socket (DHT #160891) was 3½ in. diameter × 7/16 in. wall thickness × 17 in. long. The socket was embedded in a non-reinforced concrete footing that was approximately 12 in. in diameter × 30 in. deep.

The mailbox system was evaluated using MASH test designation no. 3-60 , which consisted of a 2,420-lb 1100C small car vehicle impacting the mailbox system at an impact speed of 19 mph and an angle of 0 degrees with a ¼ vehicle offset; and test designation no. 3-61, which consisted of a 2,420-lb 1100C small car vehicle impacting the mailbox system at an impact speed of 62 mph and an angle of 0 degrees with a ¼ vehicle offset. In test no. 490023-9-3 (test designation no. 3-60), the test vehicle impacted the mailbox system at 19.5 mph and an angle of 0 degrees. Following initial impact, the mailbox support post lifted up and out of the socket, which allowed the mailbox support to rotate away from the vehicle. The mailbox detached from the support post as the assembly was overridden. The test was deemed acceptable according to the MASH criteria as all occupant risk criteria and

occupant compartment deformation and penetration criteria were met during the test. Post test photographs and sequential images of the test are shown in Figure 16. A summary of the relevant test results is shown in Table 8.

In test no. 490023-9-4 (test designation no. 3-61), the test vehicle impacted the mailbox system at 63.0 mph and an angle of 0 degrees. Following initial impact, the support post deformed and collapsed and the mailboxes rotated toward the vehicle. The support post then pulled out of the socket and moved up on the hood of the vehicle, which allowed the leading mailbox to contact and fracture the windshield. The mailboxes remained attached to the support post. There was 4.5 in. of windshield deformation and penetration of the windshield. The test was deemed unacceptable according to the MASH criteria due to the windshield damage. Post test photographs and sequential images of the test are shown in Figure 17. A summary of the relevant test results is shown in Table 9.



Mail Box	Mailbox Attachment	Mailbox-to-Post Bracket	Support Base	Support Post	Base-to-Post Attachment
<ul style="list-style-type: none"> • Dual Mailbox • 15 in. tall x 11½ in. wide x 18 in. deep • 16-gauge and 14-gauge steel • 22.6 lb each • 42-in. mounting height 	<ul style="list-style-type: none"> • Four ¾-in. diameter SAE Grade 5 bolts • ⅛-in. plate washer 	Bracket DHT# 161443	Plastic socket in reinforced concrete footing (12 in. in diameter x 30 in. deep)	<ul style="list-style-type: none"> • SHUR-TITE® mailbox post • 2⅝-in. outside diameter x 0.065-in. thick steel tube 	Socketed with locking wedge and 13-in. embedment

Figure 15. Locking Architectural Mailbox on Dual Mount Post - Test No. 490023-9-3 [7]



Figure 16. Locking Architectural Mailbox on Dual Mount Post - Test No. 490023-9-3, Test Results [7]

Table 8. Locking Architectural Mailbox on Dual Mount Post - Test No. 490023-9-3

Test no.	490023-9-3
Test Designation	3-60
Test Vehicle	1100C
Impact Speed (mph)	19.5
Vehicle Orientation	Centerline
Longitudinal OIV/ Change in Velocity (ft/s)	3.0 ft/s < 16 ft/s
Longitudinal ORA (g's)	1.4
Mailbox Release Time (sec)	No mailbox release
Post Release Time (sec)	0.077
Test Result	Pass



Figure 17. Locking Architectural Mailbox on Dual Mount Post - Test No. 490023-9-4, Test Results [7]

Table 9. Locking Architectural Mailbox on Dual Mount Post - Test No. 490023-9-4

Test no.	490023-9-4
Test Designation	3-61
Test Vehicle	1100C
Impact Speed (mph)	63.0
Vehicle Orientation	¼ Offset
Longitudinal OIV/ Change in Velocity (ft/s)	4.9 ft/s < 16 ft/s
Longitudinal ORA (g's)	1.0
Mailbox Release Time (sec)	No mailbox release
Post Release Time (sec)	0.014 – 0.31 sec
Test Result	Failure windshield penetration and deformation

2.1.7 Single Mailbox with Recycled Rubber Support Post in a Type 4 Foundation

TTI conducted MASH TL-3 crash testing of a single mailbox mounted on a recycled rubber post, as shown in Figure 18 [8]. An Elite No. 1-A (Model #E1600B00) standard arched-top medium size mailbox from Solar Group, Inc. was attached to the top of a recycled rubber support post at a height of 42 in. above grade. The mailbox weighed 7 lb and had approximate dimensions of 11 in. tall × 8¾ in. wide × 21½ in. deep. Attachment of the mailbox to the post was accomplished using a mailbox bracket (DHT #161443), two extension brackets (DHT #148938), and associated SAE grade 5 bolts, nuts, and washers. The recycled rubber support post was inserted into a Type 4 foundation socket (DHT #160891) and secured with a tapered semi-circular HDTP wedge (DHT #160892) on the impact side. The foundation socket was installed flush with the surface of a 12-in. diameter × 30-in. deep unreinforced concrete foundation.

The mailbox system was evaluated using MASH test designation no. 3-61, which consisted of a 2,420-lb 1100C small car vehicle impacting the mailbox system at an impact speed of 62 mph and an angle of 0 degrees with a ¼ vehicle offset. In test no. 469468-8-1, the test vehicle impacted the mailbox system at 63.8 mph and an angle of 0 degrees. Following initial impact, the mailbox support post deformed about the front bumper of the vehicle which caused the mailbox to be pulled down onto the vehicle's hood. As the vehicle proceeded downstream, the support post was pulled from the socket. The upper section of the mailbox remained attached to the support, and the test article was propelled in front of the vehicle. The test was deemed acceptable according to the MASH criteria as all occupant risk criteria and occupant compartment deformation and penetration criteria were met during the test. Post test photographs and sequential images of the test are shown in Figure 19. A summary of the relevant test results is shown in Table 10.



Mail Box	Mailbox Attachment	Mailbox-to-Post Bracket	Support Base	Support Post	Base-to-Post Attachment
<ul style="list-style-type: none"> • Single mailbox • Elite No. 1-a mailbox (#E1600B00) • 11 in. tall x 8¾ in. wide x 21½ in. deep • Steel • 7 lb (10 lb for mailbox and mount) • 42-in. mounting height 	<ul style="list-style-type: none"> • Bracket to post – one 5/16-in. diameter SAE Grade 5 bolts • Bracket plate to mailbox – four ¼-in. diameter SAE Grade 5 bolts • Bracket mount and mailbox – six ¼-in. bolts per unit 	<ul style="list-style-type: none"> • Bracket mount DHT#161443 • Extension bracket DHT#148938 	Plastic socket in reinforced concrete footing (12 in. in diameter x 30 in. deep)	<ul style="list-style-type: none"> • Approximately 2 ¾-in. outside diameter recycled rubber 	Socketed with locking wedge

Figure 18. Single Mailbox with Recycled Rubber Support Post in Type 4 Foundation - Test No. 469468-8-1 [8]



Figure 19. Single Mailbox with Recycled Rubber Support Post in Type 4 Foundation - Test No. 469468-8-1, Test Results [8]

Table 10. Single Mailbox with Recycled Rubber Support Post in Type 4 Foundation - Test No. 469468-8-1

Test no.	469468-8-1
Test Designation	3-61
Test Vehicle	1100C
Impact Speed (mph)	63.8
Vehicle Orientation	¼ Offset
Longitudinal OIV/ Change in Velocity (ft/s)	NA < 16 ft/s
Longitudinal ORA (g's)	NA
Mailbox Release Time (sec)	No mailbox release
Post Release Time (sec)	0.023
Test Result	Pass

2.1.8 Double Mailbox with Thin-Wall Galvanized Support Post in a Type 4 Foundation

TTI conducted MASH TL-3 crash testing of a dual mailbox mounted on a thin wall steel support post, as shown in Figure 20 [8]. Two Elite No. 1-A (Model #E1600B00) standard arched-top medium size mailboxes from Solar Group, Inc. were attached to the top of a galvanized, thin-wall steel support post at a height of 42 in. above grade. The mailboxes weighed 7 lb and had approximate dimensions of 11 in. tall × 8¾ in. wide × 21½ in. deep. A mailbox bracket (DHT #161443) and extension bracket (DHT #148938) were attached to the bottom of each mailbox using SAE grade 5 bolts, nuts, and washers. Attachment of the Elite mailboxes to the post was accomplished using a bracket (DHT #162323) that consisted of a horizontal steel plate and tubular socket. The mailboxes were bolted to the horizontal plate at a center-to-center spacing of 10 in. The bracket socket was then placed over the end of the support post and secured using a ⅜-in. diameter × 3½-in. long SAE grade 5 hex bolt, flat and lock washers, and nut. The galvanized steel support post (DHT #143426) was fabricated from 2-in. nominal 16-gauge (2⅜-in. outside diameter × 0.109-in. wall thickness) thin wall ASTM A513 Type 5 DOM steel tubing. The support post, which had a length of 57 in., was inserted into a Type 4 foundation socket (DHT #160891) and secured with a tapered semi-circular HDTP wedge (DHT #160892) on the impact side. The foundation socket was installed flush with the surface of a 12-in. diameter × 30-in. deep unreinforced concrete foundation.

The mailbox system was evaluated using MASH test designation no. 3-61, which consisted of a 2,420-lb 1100C small car vehicle impacting the mailbox system at an impact speed of 62 mph and an angle of 0 degrees with a ¼ vehicle offset. In test no. 469468-8-2, the test vehicle impacted the mailbox system at 63.3 mph and an angle of 0 degrees. Following initial impact, the mailbox support post deformed about the front bumper of the vehicle which caused the mailbox to be pulled down onto the vehicle's hood. As the vehicle proceeded downstream, the support post was pulled from the socket. The upper section of the mailbox remained attached to the support, and the test article was propelled in front of the vehicle. The test was deemed acceptable according to the MASH criteria as all occupant risk criteria and occupant compartment deformation and penetration criteria were met during the test. Post test photographs and sequential images of the test are shown in Figure 21. A summary of the relevant test results is shown in Table 11.



Mail Box	Mailbox Attachment	Mailbox-to-Post Bracket	Support Base	Support Post	Base-to-Post Attachment
<ul style="list-style-type: none"> • Dual mailbox • Elite No. 1-a mailbox (#E1600B00) • 11 in. tall x 8¾ in. wide x 21½ in. deep • Steel • 7 lb (20 lb for both mailboxes and bracket) • 42-in. mounting height 	<ul style="list-style-type: none"> • Collar bracket to post – one ¾-in. diameter SAE Grade 5 bolt • Extension bracket to bracket mount and mailbox – four ¾-in. diameter SAE Grade 5 bolts • Extension bracket to bracket mount and mailbox – eight ¼-in. bolts per unit 	<ul style="list-style-type: none"> • Bracket mount DHT#161443 • Extension bracket DHT#148938 • Collar bracket DHT#162323 	Plastic socket in reinforced concrete footing (12 in. in diameter x 30 in. deep)	<ul style="list-style-type: none"> • 2¾-in. outside diameter 16 gauge thick • ASTM A513 type 5 DOM • 57 in. long • 7.5 lb 	Socketed with locking wedge and 15-in. embedment

Figure 20. Double Mailbox with Thin-Wall Galvanized Support Post in Type 4 Foundation - Test No. 469468-8-2 [8]



Figure 21. Double Mailbox with Thin-Wall Galvanized Support Post in Type 4 Foundation - Test No. 469468-8-2, Test Results [8]

Table 11. Double Mailbox with Thin-Wall Galvanized Support Post in Type 4 Foundation - Test No. 469468-8-2

Test no.	469468-8-2
Test Designation	3-61
Test Vehicle	1100C
Impact Speed (mph)	63.3
Vehicle Orientation	¼ Offset
Longitudinal OIV/ Change in Velocity (ft/s)	2.6 ft/s < 16 ft/s
Longitudinal ORA (g's)	0.5
Mailbox Release Time (sec)	No mailbox release
Post Release Time (sec)	0.022
Test Result	Pass

2.1.9 MASH Mailbox Testing Conclusions

Following the collection and review of relevant MASH mailbox testing, the researchers drew several conclusions. First, test designation no. 3-61, which consists of a 1100C vehicle impacting at high speed, appeared to be the most critical test for evaluation of mailboxes. Results from the previous mailbox testing demonstrated that test designation no. 3-61 increased the propensity for the mailbox support to interact with the vehicle windshield and result in test failure. Test designation no. 3-60, which involves the low-speed impact of a 1100C vehicle, was observed to be less critical due to the mailbox typically being pushed down in front of the vehicle at low speeds. This tended to limit the potential for the mailbox to violate the occupant compartment and windshield criteria. Additionally, because mailbox supports are typically small post sections or were socketed, the knockdown or release of the post did not pose significant risk to the impacting vehicle. It was also noted that test designation no. 3-62, which consists of the high-speed impact of a 2270P vehicle, was not conducted on any of the previous MASH mailbox evaluations. This test was omitted because the height of typical mailbox installations relative to the height of the front of the pickup truck is low enough that the potential for the mailbox to move over the hood and toward the windshield is extremely limited.

Analysis of the previous mailbox testing results also identified several critical factors that appeared to affect their safety performance. First, heavier mailboxes and/or multiple mailbox configurations appeared to be more critical than lighter, single mailbox configurations. This was attributed to high mass mailbox configurations posing an increased risk for detaching from the support and reaching the vehicle windshield. The higher mass would tend to increase the loading to the windshield. Similarly, it was apparent that mailboxes that remained attached to the support post had better safety performance than those that detached. Detachment of the mailbox was generally accompanied by impact of the mailbox on the windshield which caused excessive windshield deformation and/or windshield penetrations. Finally, it was noted that ductile support posts that do not immediately release from their base seemed to perform well. The ability of the post to wrap around the front profile of the small car appeared to pull the mailbox down toward the hood and prevent contact of the mailbox with the windshield as long as the mailbox remained attached to the support post. This would suggest that a dedicated breakaway mechanism, such as a slip base at the bottom of the post, would add unnecessary complexity to these types of devices.

No PSST mailbox supports were evaluated to MASH or any of the previous hardware evaluation criteria. Discussion of MASH PSST sign support testing is covered in Section 2.2.

2.2 MASH PSST Sign Support Testing

Previous MASH testing of PSST sign supports was also collected as part of the research efforts [9-10]. Only a very limited number of MASH tests of PSST sign supports were available at the time of this study. The PSST sign supports reviewed tended to use larger post sections than the proposed mailbox support to accommodate wind loads and used breakaway bases in some applications. Additionally, the PSST sign supports had panel mounting heights much higher than mailboxes. The limited number of available PSST sign support testing and the differences between the sign supports and mailbox supports in terms of section size and mounting height made it difficult to determine information from the PSST sign tests that was relevant to the mailbox support design in this research.

2.3 NDOT Mailbox Rule

The researchers were provided with a draft of NDOT's proposed rule regarding mailboxes. While that draft was not finalized, it provided some guidance relative to the scope of the mailbox support effort. The draft rule followed current United States Postal Service (USPS) mailbox guidance [11] with some additional criteria specified by NDOT. The draft rule provided the following information.

1. NDOT proposed to allow any standard, large mailbox configuration. The size limitation on the mailbox was set at 11 in. high \times 14 in. wide \times 25 in. deep.
2. The mailbox materials were limited to lightweight sheet metal or durable thin gauge plastic.
3. No mass limitations were given for the mailboxes.
4. Mounting heights were listed between 39 in. to 48 in. to the bottom of the mailbox. It was noted that this height range was larger than the 41 in. to 45 in. range specified in USPS regulations.
5. Integrated newspaper boxes were not allowed, but separate newspaper boxes were allowed on the mailbox supports. As these newspaper boxes are typically lightweight plastic, they were not considered relevant for the mailbox support research effort.

2.4 Commercially Available Mailboxes

For the final piece of background material relevant to this research effort, the researchers collected available mailboxes and associated mounting hardware that fit within the NDOT draft rule criteria for consideration during the design effort. The collected mailboxes and mounting hardware are summarized in Appendix A. Note while plastic mailboxes were allowed in the NDOT draft rule, they were omitted from the collected mailboxes due to their low weight making them less critical from a design standpoint.

Data from the collected mailboxes found that mailboxes within the NDOT draft rule specifications could vary significantly in mass and ranged from 4.5 lb to 25 lb. Mailbox mounting methods also varied widely with some designs using bolts through the base of the mailbox while others bolted through the lower side flanges of the mailbox. The spacing and size of the mounting hole locations varied as well. Thus, review of generic mailbox mounting brackets was also completed to determine what types of connections would need to be accommodated in the NDOT mailbox support.

3 DESIGN OF PSST MAILBOX SUPPORT

Following the literature search, MwRSF began the process of determining design concepts for a MASH-compliant PSST mailbox support. The effort began with review of a PSST mailbox support proposed at the onset of the effort by NDOT. MwRSF and NDOT worked together to establish design criteria for a new mailbox support. MwRSF then developed single and dual mailbox support designs for the initial dynamic component testing.

3.1 Original Proposed NDOT Mailbox Support

At the onset of the research effort, NDOT supplied a proposed mailbox mount to MwRSF for consideration as a starting point for the design process, as shown in Figure 22. The NDOT mailbox design consisted of a 2-in. × 14-gauge PSST support post inserted in a 2¼-in. × 12-gauge PSST embedded stub. The stub section of the mailbox support was 36 in. long and extended 4 in. above grade. The PSST support post was inserted 6 in. into the lower stub. Both the support post and embedded stub were made of ASTM A1011 Grade 50 steel. A mailbox mount was created by welding a 1/16-in. thick ASTM A36 plate to a 1¾-in. × 14-gauge PSST stub inserted 5 in. into the top of the PSST support post. The support post was connected to the embedded stub and mounting plate stub with 5/16-in. diameter corner bolts. Four ¼-in. diameter Phillips round head bolts were used to attach the mounting plate to the base of the mailbox.

Comparison of this design to previously tested mailbox systems and existing mailboxes led the researchers to note that there may be design modifications to the proposed mailbox support. First, it was noted that the mounting plate may need to be modified to accept mounting bolts from a wider variety of mailbox types. Second, it was noted that the mailbox mount currently used a PSST stub at the base of the mounting plate which could make fabrication difficult. PSST currently is only readily available in galvanized form. As such, welding a tube to the base plate could be difficult due to toxicity and weld issues associated with welding galvanized steel. Finally, the previous testing of mailbox supports suggested that the strength of the connection between the mailbox mount and mailbox was critical to retaining the mailbox to the support and the overall safety performance of the mailbox support. As such, it was noted that increasing the size, grade, or number of attachment bolts may need to be considered depending on the mass of the mailbox used with the support.

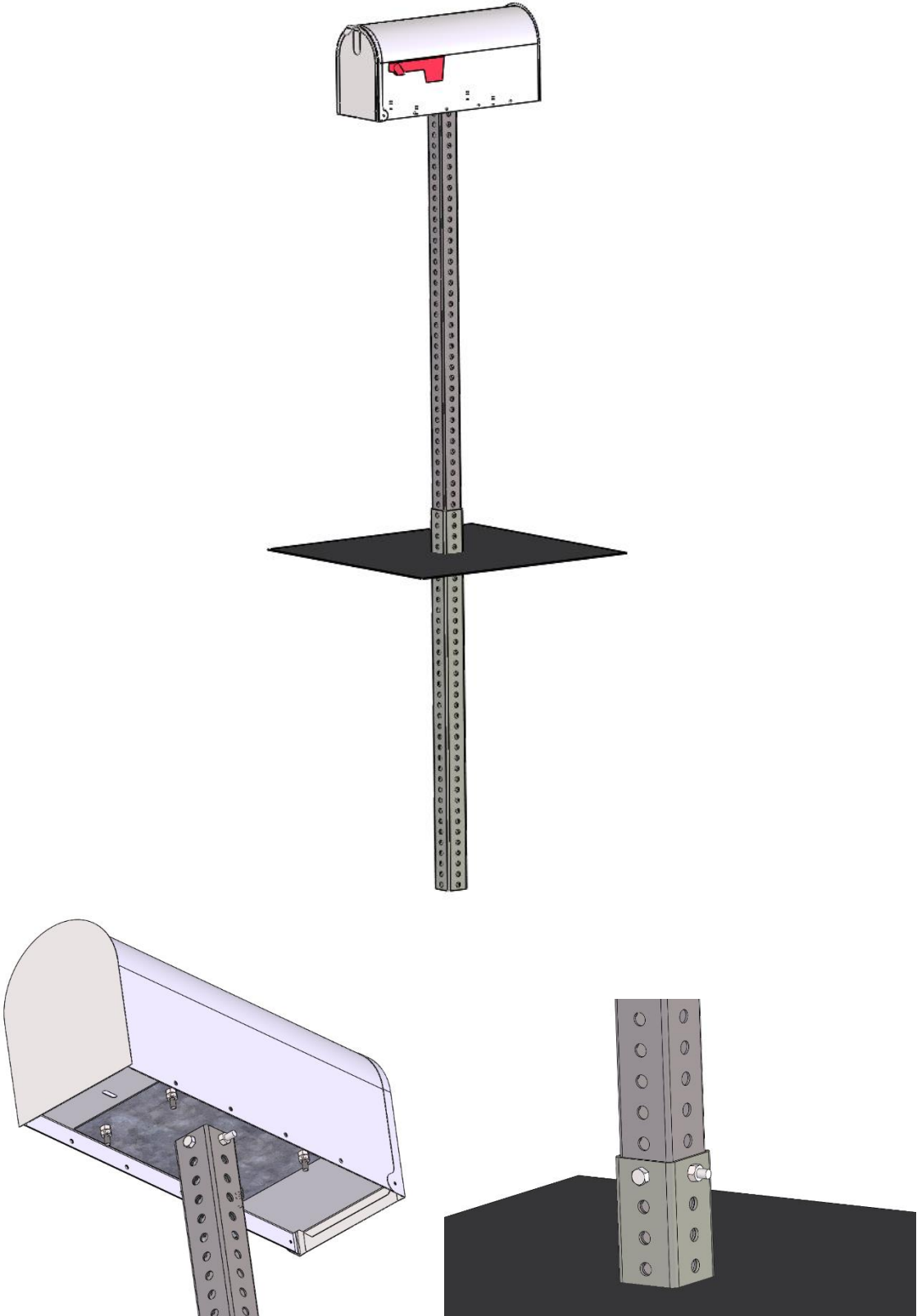

Figure 22. NDOT Original PSST Mailbox Support Design Concept

3.2 Mailbox Support Design Criteria

MwRSF researchers collaborated with NDOT representatives to determine design criteria for the MASH-compliant mailbox support. As noted previously, NDOT wished the design to be based on their original proposed mailbox support, but several design criteria relative to the mailbox design needed to be determined prior to development of a mailbox support for dynamic component testing.

The first design criteria dealt with the mass of the mailboxes to be evaluated. Previously, the researchers had noted that available mailboxes within the size range allowed by NDOT could weigh as much as 25 lb. Review of existing full-scale crash tests of mailboxes indicated that heavier mailboxes tended to be more critical in terms of safety performance as they had a higher propensity for detaching from the mailbox support and tended to induce greater damage to the vehicle. Consequently, mailbox mounting hardware for heavier mailboxes was more robust and/or complex to accommodate the increased mailbox weight. Successful safety performance for heavy mailboxes was only accomplished through the use of larger mounting hardware diameter and/or grade or the use of additional mounting brackets to increase the number of attachment points. Many existing mailboxes are provided with only a limited number and size of mounting holes, as shown in Figure 23, and improving the connection of these mailboxes to the mailbox support might require modification of the mailbox itself. NDOT representatives did not desire to add complexity to the mailbox mount or require modification of available mailboxes in order to achieve acceptable safety performance. Thus, it was decided to limit the new PSST mailbox mount design to mailboxes with a weight of 10 lb or less. It was believed that this weight would allow for effective attachment of mailboxes without modification other than upgrading the grade or size of the mounting hardware.

The mounting height of the mailbox support was also reviewed. NDOT guidance allowed mailboxes to be mounted between 39 in. and 48 in. to the bottom of the mailbox and USPS regulations provide a range of 41 in. to 45 in. Previous MASH full-scale crash testing was consistently conducted with the mailbox with a height of 42 in. to the base of the mailbox. Mailbox mounting heights above 42 in. may create increased extension of the mailbox over the vehicle hood during impact and increase the propensity for contact with the vehicle windshield. To make the new mailbox support consistent with previous designs and limit variability in performance, NDOT elected to establish a mounting height of 42 in. for the mailbox support and planned to update their draft rule to establish a 42-in. mounting height as the standard.

Because the mailbox support was to be based on PSST, MwRSF noted to NDOT that PSST manufacturers have a variety of prefabricated PSST mounts that could potentially be used to attach the support post to the mailbox mounting bracket. Additionally, there were several commercially available mailbox mounting brackets available for single or dual mailbox mounts. Thus, MwRSF and NDOT discussed the use of the commercially available components in the design. NDOT indicated that they preferred simple, non-proprietary mounting hardware if possible. Thus, they wished to retain a simple plate type mailbox mount with that could be fabricated easily for the mailbox support.

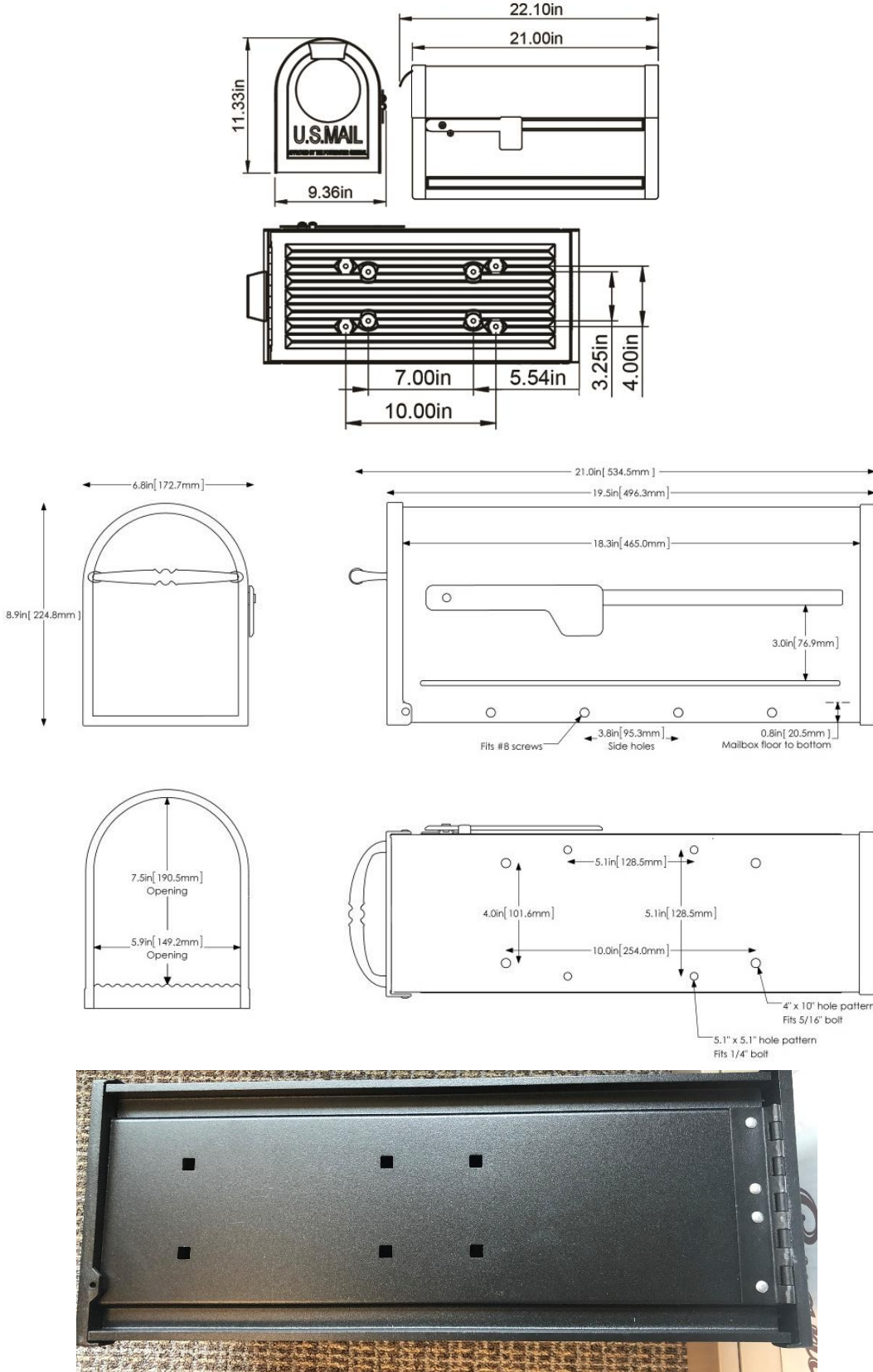

Figure 23. Various Mailbox Mounting Configurations

It was noted the originally proposed NDOT mailbox support design connected the support post to the stub and the mounting bracket with $\frac{5}{16}$ -in. diameter corner bolts. These bolts were typically low-grade bolt material and were lower in terms of capacity than the mailbox mount attachment hardware. As such, there was some concern that the corner bolts would limit the ability of the support to retain the mailbox during impact. However, because those connections combine socketing of the adjacent tubes in addition to the corner bolts, it was decided to use the corner bolts until a problem was identified in dynamic testing.

Finally, NDOT requested development of both single and dual mailbox supports. As such, details were proposed for both single and dual mailbox options.

3.3 Single Mailbox Support Concept

A single mailbox mount concept was developed based on the previously-described original design concept from NDOT and information gleaned from the literature review, as shown in Figure 24. The support post and embedded stub remained unchanged from the original NDOT concept and consisted of a 2-in. \times 14-gauge PSST and a $2\frac{1}{4}$ -in. \times 12-gauge PSST, respectively. The stub was 36 in. long and embedded 32 in. into the ground. The support post was socketed 6 in. inside the stub and was connected to the stub with a $\frac{5}{16}$ -in. diameter corner bolt. The mailbox mount was modified from the original NDOT design. The mounting plate was fabricated from 14-gauge ASTM 1011 Grade 50 steel. The shape of the mounting plate was modified to add bent flanges on the side and additional mounting holes. These modifications were made to allow for attachment of the wide variety of base-mounted and side flange-mounted mailboxes that could potentially be used with the mailbox support. The mounting plate was welded to a $2\frac{1}{2}$ -in. \times $2\frac{1}{2}$ -in. \times $\frac{3}{16}$ -in. steel tube that socketed over the support post and was held in place by a $\frac{5}{16}$ -in. diameter corner bolt. Both Grade 2 and Grade 5 mailbox attachment hardware were considered for the single mailbox support concept.

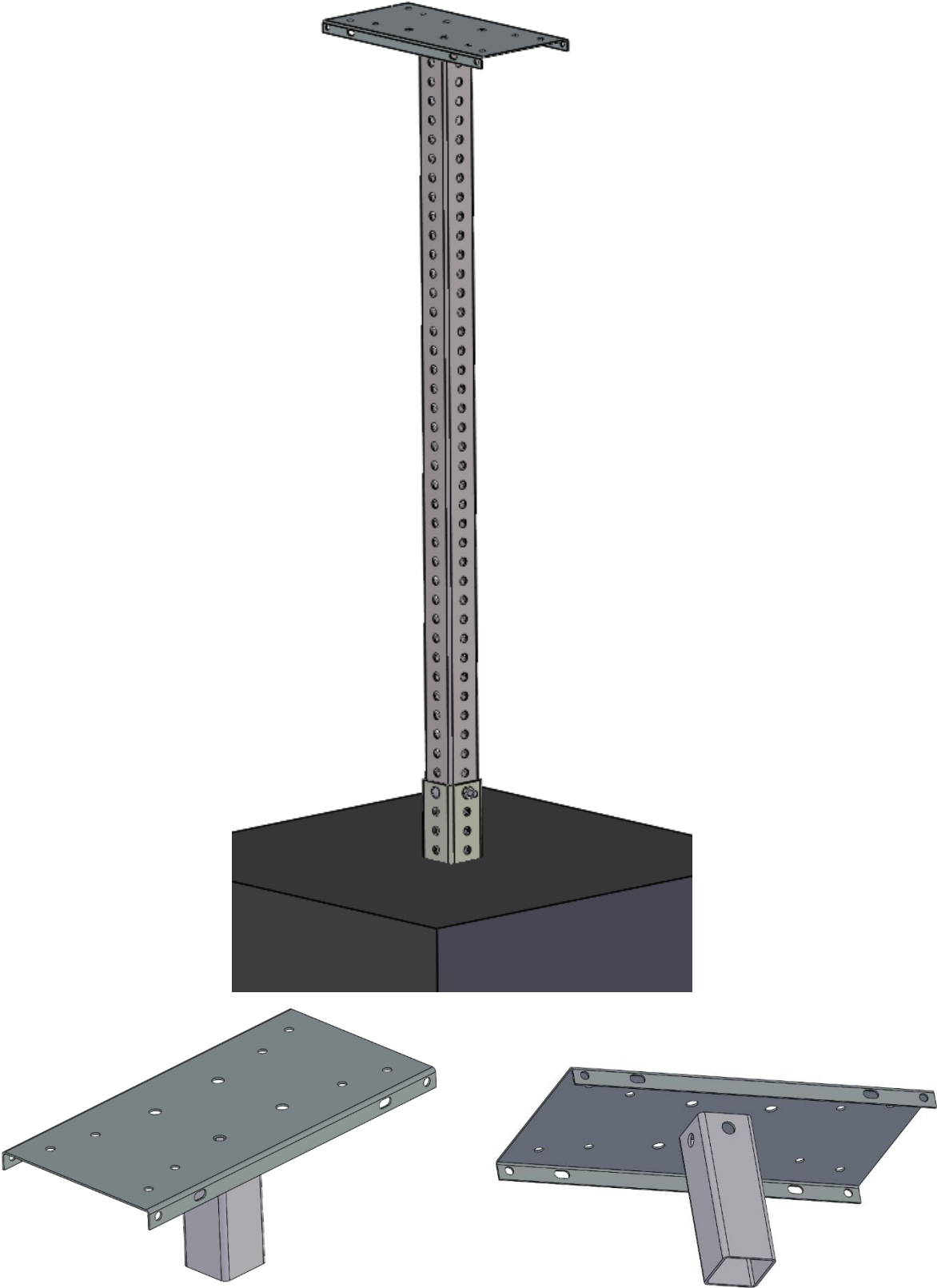

Figure 24. Single Mailbox Support Concept

3.4 Dual Mailbox Support Concept

3.4.1.1 Non-Proprietary Dual Mailbox Mount Concepts

NDOT requested that the researchers develop a dual mailbox support concept based on the single mailbox support. The dual mailbox support concepts used the same stub and support post as the single mailbox support concept but modified the mailbox mounting bracket to accommodate two mailboxes. Two modified mounting bracket concepts were developed based on the extension of the single mounting bracket to a dual mailbox configuration. The first concept consisted of a single bent plate that had two mailbox mounting sections with a flat section of plate between them, as shown in Figure 25. A tube socket was welded beneath the midspan of the plate for attachment to the support post, and gussets were welded beneath the plate to support the cantilevered weight of the mailboxes and reinforce the mounting bracket. The second dual mailbox mounting bracket concept is shown in Figure 26. This concept uses a gusseted flat plate welded to the tube socket. Separate mounting bracket parts could then be bolted to the plate to accommodate dual mailboxes.

NDOT reviewed both proposed dual mailbox mounting options. While both mounts were perceived to meet the design goals, it was believed that they would be complicated and costly to fabricate compared to some of the commercially available dual mailbox mounting brackets. NDOT preferred a dual mailbox mount made by TAPCO that they had used on previous mailbox supports. Thus, the researchers were asked to adopt the TAPCO dual mailbox mount to the proposed PSST mailbox support.

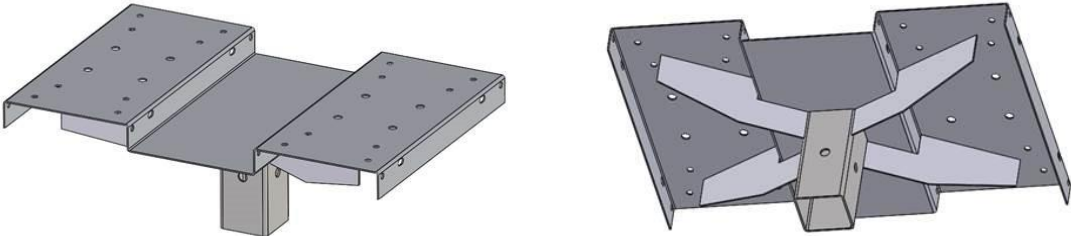

Figure 25. Non-Proprietary Dual Mailbox Support Bracket Concept No. 1

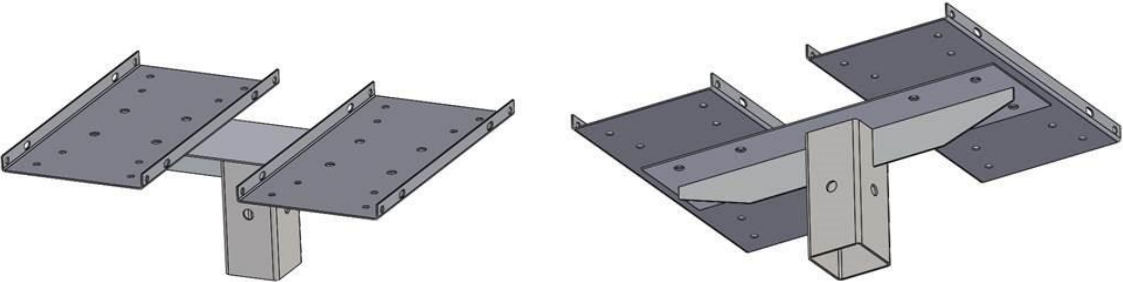

Figure 26. Non-Proprietary Dual Mailbox Support Bracket Concept No. 2

3.4.1.2 TAPCO Dual Mailbox Mount Concept

NDOT had previously used the TAPCO dual mailbox mount kit (Part no. 034-00045) and requested that MwRSF adopt that mailbox mount to the proposed PSST support, as shown in Figure 27. The TAPCO mount was intended for use with a circular, 2-in. diameter tube post manufactured by TAPCO. The kit contains a pair of two-piece, adjustable, 16-gauge mounting brackets and a 14-gauge flat plate bracket. The mount used $\frac{5}{16}$ -in. diameter spade bolts to connect the support to the flat plate bracket. The adjustable mailbox brackets were bolted to the flat plate bracket with $\frac{5}{16}$ -in. truss head machine screws. The adjustable mailbox brackets facilitated attachment of mailboxes through the lower flange of the mailbox with #10 machine screws.

Review of the TAPCO mount identified several considerations to take into account when adopting the design for the proposed PSST support. First, the mounting bracket configuration allowed mailbox attachment through the lower flange of the mailbox with small diameter, low-grade mounting hardware. Side flange mounting would be limited to lighter mailbox options with side flange mounts as heavier mailboxes tended to use only base bolting options. The #10 machine screws used to attach the mailboxes were lower capacity than the hardware used in previous MASH crash tested mailbox supports, so there was some concern that the mailboxes may detach during impact with the smaller hardware. Similar concerns for mailbox detachment were noted with respect to the $\frac{5}{16}$ -in. diameter spade bolts used in the mount. The TAPCO mount was also not designed for use with PSST. Thus, the mount would need to connect to the PSST with the available hardware in some manner.

The TAPCO mount only required minor modifications for use with the PSST support. The mailbox weight for the dual support was limited to 3 to 5-lb mailboxes. This reduced concerns for mailbox detachment and ensured that commercially available mailboxes would have side flanges compatible with the mounting bracket. The $\frac{5}{16}$ -in. diameter spade bolts were compatible for attachment to the 2-in. square PSST support post through the use of a $\frac{5}{16}$ -in. diameter hex bolt supplied with the kit. As such, the supplied TAPCO mounting hardware was used for attachment of the spade bolts to the PSST and attachment of the flat plate bracket to the adjustable mailbox brackets. The mounting bolts for attachment of the mailbox to the mounting brackets were upgraded to $\frac{1}{4}$ -in. diameter SAE Grade 5 hardware to mitigate concerns for mailbox detachment. The modified TAPCO dual mailbox mount on the PSST support is shown schematically in Figure 28.



Figure 27. TAPCO Dual Mailbox Mounting Kit

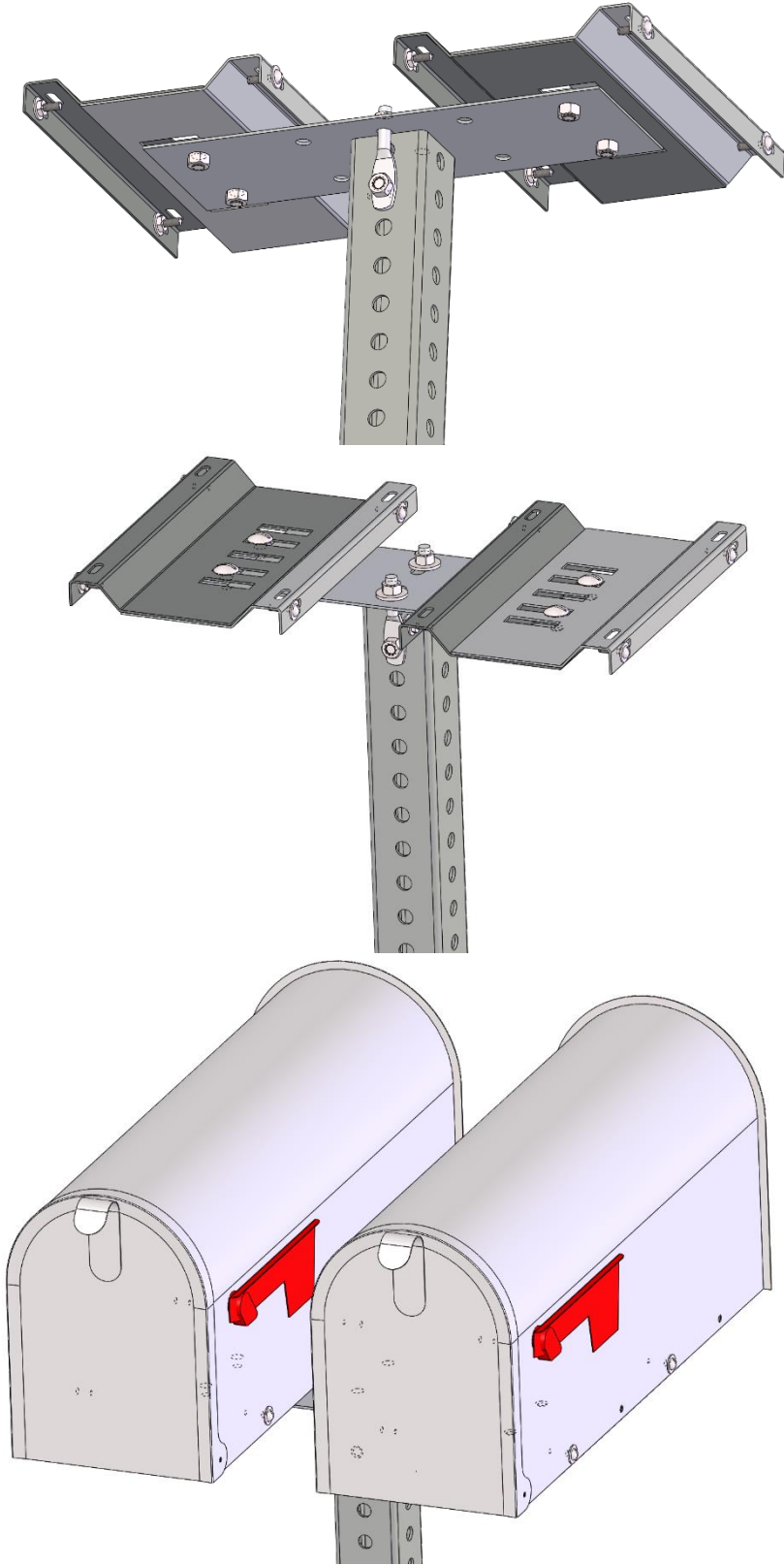

Figure 28. Modified TAPCO Dual Mailbox Mount for PSST Mailbox Support

4 TEST REQUIREMENTS AND EVALUATION CRITERIA

4.1 Test Requirements

Support structures, such as mailbox supports, must satisfy impact safety standards to be declared eligible for federal reimbursement by the Federal Highway Administration (FHWA) for use on the National Highway System. For new and existing hardware, these safety standards consist of the guidelines and procedures published in MASH. According to TL-3 criteria, support structures must be subjected to three full-scale vehicle crash tests, as summarized in Table 12.

Table 12. MASH TL-3 Crash Test Conditions for Support Structures

Test Article	Test Designation No.	Test Vehicle	Vehicle Weight, lb	Impact Conditions		Evaluation Criteria ¹
				Speed, mph	Angle, degrees	
Support Structures	3-60	1100C	2,420	19	CIA	3-60
	3-61	1100C	2,420	62	CIA	3-61
	3-62	2270P	5,000	62	CIA	3-62

¹ Evaluation criteria explained in Table 13.

Surrogate vehicle testing was planned for the research and development effort in accordance with MASH test designation no. 3-61 on two prototype mailbox supports. Each mailbox support installation was contacted by the surrogate, reusable, 1100C test vehicle at a 0-degree angle. MASH notes that the critical impact angle (CIA) should be selected to represent the highest risk for the system to fail any of the recommended evaluation criteria. Since permanent sign supports are not typically installed 90 degrees from the normal direction of travel, a critical impact angle ranging between 0 and 25 degrees is recommended. Historically, mailbox support systems have been impacted using a 0-degree angle due to a belief that it provided the most critical condition for maximizing the potential for the mailbox to disengage from the support and move directly toward and make contact with the windshield. The critical impact point in each test was the right or left quarter point of the vehicle's front bumper in accordance with MASH recommendations. For this exploratory research effort, a 0-degree CIA was evaluated on the single mailbox support and a 10-degree CIA was evaluated on the dual mailbox support, although further evaluation is recommended to determine if non-zero impact angles are more critical for single, U-channel, breakaway sign support evaluations.

Note that although the surrogate, non-compliant, 1100C test vehicle was similar to a compliant 1100C MASH small car, the test results were considered exploratory in nature. Thus, the test results were believed to be consistent with MASH 1100C crash performance according to MASH test designation no. 3-61 specifications but do not constitute a compliant test. Additionally, MASH test designation nos. 3-60 and 3-62 impact conditions were not conducted as part of this research and development effort. While these tests were deemed non-critical for the evaluation of mailbox supports, it may be worth considering evaluation of the system with the complete test matrix to build further confidence in the safety performance of these types of systems as part of

the implementation of MASH due to the lack of experience and knowledge regarding the performance of new vehicle types with certain types of hardware. Additionally, further investigation may be necessary to evaluate system performance at non-zero impact angles, up to 25 degrees as specified in MASH.

4.2 Evaluation Criteria

Evaluation criteria for vehicle crash testing were based on three appraisal areas: (1) structural adequacy; (2) occupant risk; and (3) vehicle trajectory after collision. Criteria for structural adequacy included the test article should readily activate in a predictable manner by breaking away, fracturing, or yielding. Occupant risk evaluated the degree of hazard to occupants in the impacting vehicle. Post-impact vehicle trajectory was a measure of the potential of the vehicle to result in a secondary collision with other vehicles and/or fixed objects, thereby increasing the risk of injury to the occupants of the impacting vehicle and/or other vehicles. These evaluation criteria are summarized in Table 13 and are defined in greater detail in MASH 2016.

It is important to note that in tests of breakaway features, the impulse on the vehicle may be relatively small and of short duration. It is not unusual for x and y in the flail-space model to be less than 2 ft and 1 ft, respectively, during the period in which accelerations are recorded or up to the time brakes are applied to the test vehicle. As specified in Section A5.5.2 of MASH, in such cases, it is recommended that the OIV be set equal to the vehicle's change in velocity that occurs during contact with the test article, or parts thereof [4]. If parts of the test article remain with the vehicle after impact, the vehicle's change in velocity should be computed at the time the vehicle clears the footing or foundation of the test article.

In addition to the standard occupant risk measures, the Post-Impact Head Deceleration (PHD), Theoretical Head Impact Velocity (THIV), and Acceleration Severity Index (ASI) were determined and reported. Additional discussion on PHD, THIV, and ASI is provided in MASH.

4.3 Soil Strength Requirements

In accordance with Chapter 3 and Appendix B of MASH, foundation soil strength must be verified before any full-scale crash testing can occur. Because the testing conducted on the mailbox supports was not MASH compliant, no verification of soil strength was performed prior to the testing. Note that the mailbox supports were installed using the same soil materials and backfill and compaction procedures used by MwRSF in full-scale testing of soil dependent hardware systems.

Table 13. MASH Evaluation Criteria for Mailboxes

Structural Adequacy	B. The test article should readily activate in a predictable manner by breaking away, fracturing, or yielding.					
Occupant Risk	D. Detached elements, fragments or other debris from the test article should not penetrate or show potential for penetrating the occupant compartment, or present an undue hazard to other traffic, pedestrians, or personnel in a work zone. Deformations of, or intrusions into, the occupant compartment should not exceed limits set forth in Section 5.2.2 and Appendix E of MASH.					
	F. The vehicle should remain upright during and after collision. The maximum roll and pitch angles are not to exceed 75 degrees.					
	H. Occupant Impact Velocity (OIV) (see Appendix A, Section A5.2.2 of MASH for calculation procedure) should satisfy the following limits:					
	Occupant Impact Velocity Limits					
	<table border="1" style="width: 100%; border-collapse: collapse;"> <thead> <tr> <th style="width: 50%;">Component</th> <th style="width: 25%;">Preferred</th> <th style="width: 25%;">Maximum</th> </tr> </thead> <tbody> <tr> <td style="text-align: center;">Longitudinal</td> <td style="text-align: center;">10 ft/s</td> <td style="text-align: center;">16 ft/s</td> </tr> </tbody> </table>	Component	Preferred	Maximum	Longitudinal	10 ft/s
Component	Preferred	Maximum				
Longitudinal	10 ft/s	16 ft/s				
I. The Occupant Ridedown Acceleration (ORA) (see Appendix A, Section A5.2.2 of MASH for calculation procedure) should satisfy the following limits:						
Occupant Ridedown Acceleration Limits						
<table border="1" style="width: 100%; border-collapse: collapse;"> <thead> <tr> <th style="width: 50%;">Component</th> <th style="width: 25%;">Preferred</th> <th style="width: 25%;">Maximum</th> </tr> </thead> <tbody> <tr> <td style="text-align: center;">Longitudinal and Lateral</td> <td style="text-align: center;">15.0 g's</td> <td style="text-align: center;">20.49 g's</td> </tr> </tbody> </table>	Component	Preferred	Maximum	Longitudinal and Lateral	15.0 g's	20.49 g's
Component	Preferred	Maximum				
Longitudinal and Lateral	15.0 g's	20.49 g's				
Post-Impact Vehicular Response	N. Vehicle trajectory behind the test article is acceptable.					

5 TEST CONDITIONS

5.1 Test Facility

The Outdoor Test Site is located at the Lincoln Air Park on the northwest side of the Lincoln Municipal Airport and is approximately 5 miles northwest of the University of Nebraska-Lincoln.

5.2 Vehicle Tow and Guidance System

A reverse-cable tow system with a 1:2 mechanical advantage was used to propel the test vehicle. The distance traveled and the speed of the tow vehicle were one-half that of the test vehicle. The test vehicle was released from the tow cable before impact with the barrier system. A digital speedometer on the tow vehicle increased the accuracy of the test vehicle impact speed.

A vehicle guidance system developed by Hinch [13] was used to steer the test vehicle. A guide flag, attached to the left-front wheel and the guide cable, was sheared off before impact with the barrier system. The $\frac{3}{8}$ -in. diameter guide cable was tensioned to approximately 3,500 lb and supported both laterally and vertically every 100 ft by hinged stanchions. The hinged stanchions stood upright while holding up the guide cable, but as the vehicle was towed down the line, the guide flag struck and knocked each stanchion to the ground.

5.3 Test Vehicles

For test no. NMB-1, a 2014 Hyundai Accent was used as the test vehicle. Testing with a non-compliant, surrogate MASH vehicle allowed the mailboxes to be more effectively evaluated than a standard sled test because the surrogate vehicle would provide more accurate impact performance and insight regarding the potential for windshield damage and occupant compartment penetration risks. The curb, test inertial, and gross static vehicle weights were 2,519 lb, 2,471 lb, and 2,471 lb, respectively. The test vehicle is shown in Figure 29, and vehicle dimensions are shown in Figure 30. Note that pre-test photographs of the vehicle's interior floorboards and undercarriage are not available.

MASH requires test vehicles used in crash testing to be no more than six model years old. A 2014 model was used for this test because the vehicle geometry of newer models did not comply with recommended vehicle dimension ranges specified in Table 4.1 of MASH. A vehicle outside the MASH age requirement was used for the testing detailed herein as it was exploratory in nature and reduced the cost of the testing.

The longitudinal component of the center of gravity (c.g.) was determined using the measured axle weights the vertical component of the c.g. for the 1100C vehicle was determined utilizing a procedure published by SAE [14]. The final c.g. location is shown in Figure 30.

Ballast information and data used to calculate the location of the c.g. are shown in Appendix C. Square, black-and-white checkered targets were placed on the vehicle for reference, as shown in Figure 31, to serve as a reference in the high-speed digital video and aid in the video analysis. Round, checkered targets were placed at the c.g. on the left-side door, the right-side door, and the roof of the vehicle.

The front wheels of the test vehicle were aligned to vehicle standards except the toe-in value was adjusted to zero such that the vehicles would track properly along the guide cable. A 5B flash bulb was mounted under the vehicle's left-side windshield wiper and was fired by a pressure tape switch mounted at the impact corner of the bumper. The flash bulb was fired upon initial impact with the test article to create a visual indicator of the precise time of impact on the high-speed digital videos. A radio-controlled brake system was installed in the test vehicle so the vehicle could be brought safely to a stop after the test.

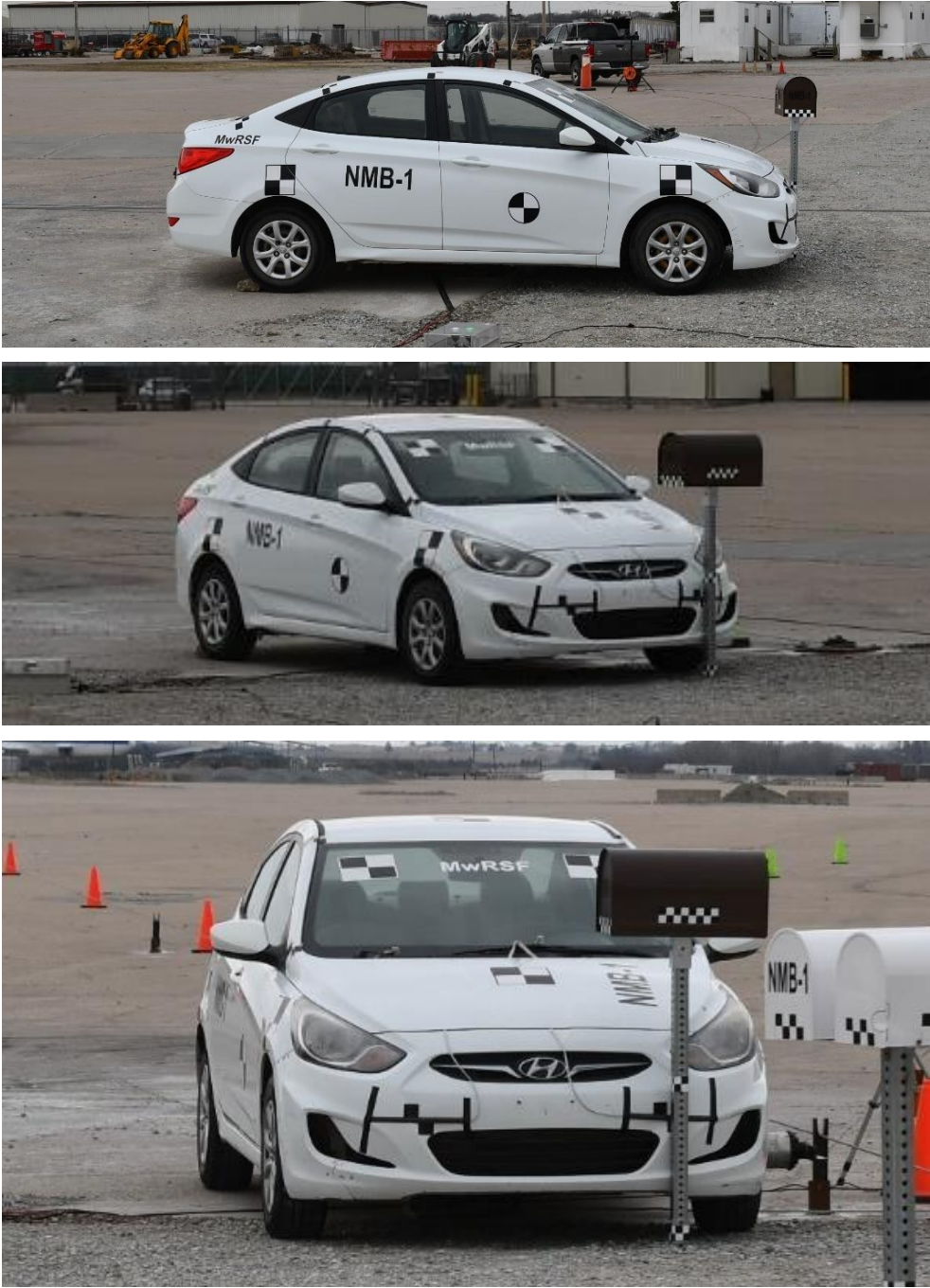

Figure 29. Test Vehicle, Test No. NMB-1

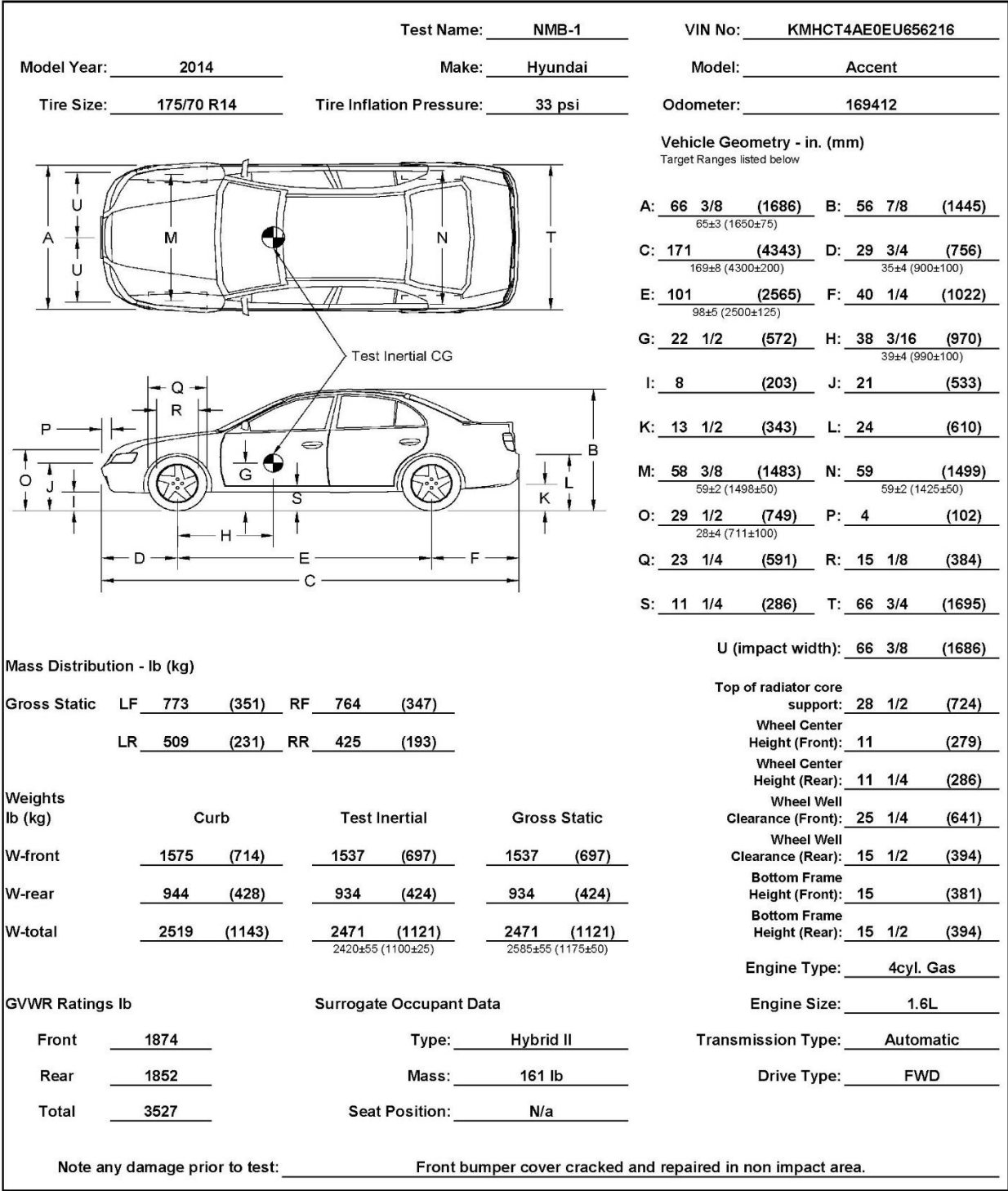

Figure 30. Vehicle Dimensions, Test No. NMB-1

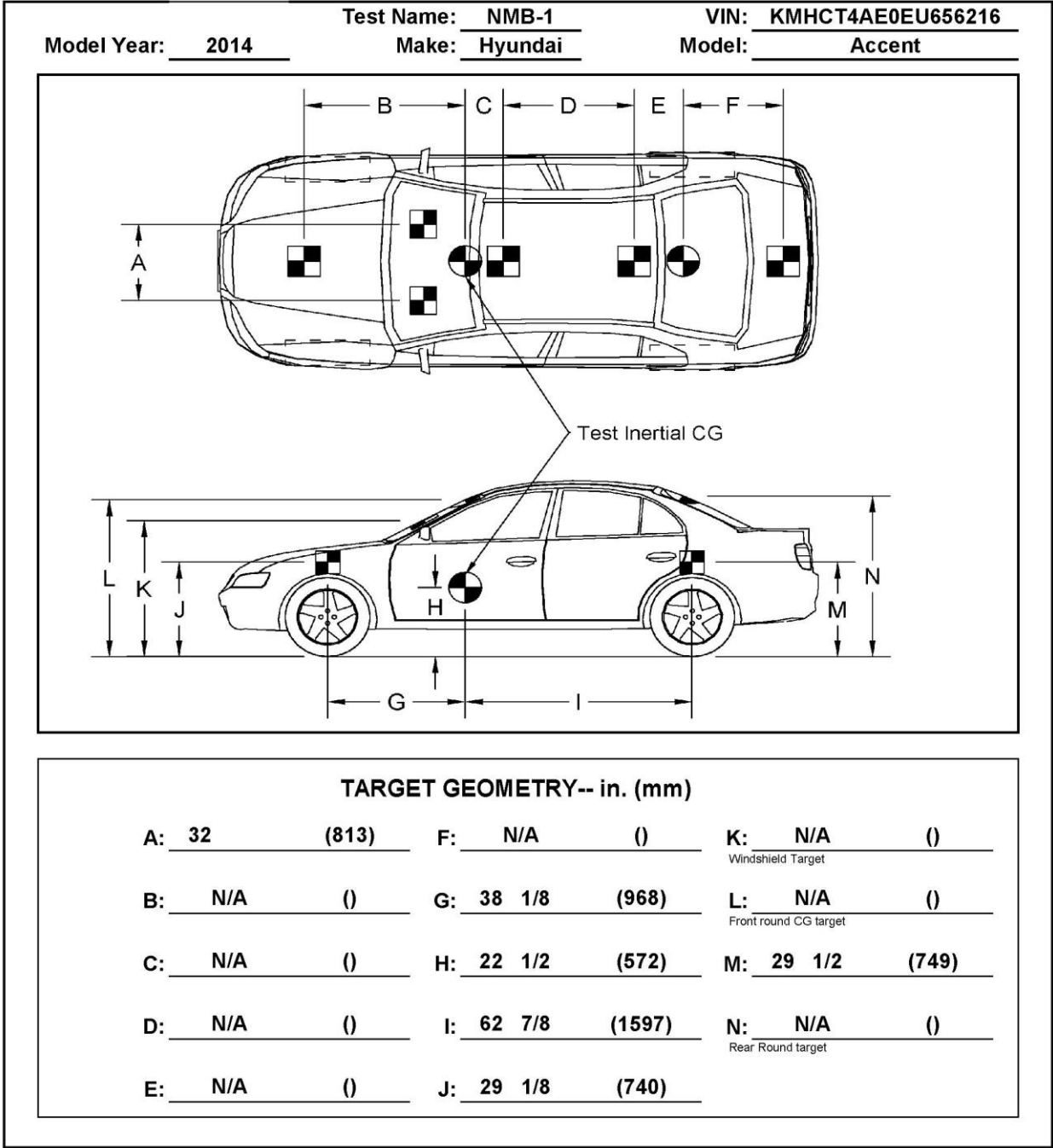

Figure 31. Target Geometry, Test No. NMB-1

5.4 Simulated Occupant

For full-scale crash testing, a Hybrid II 50th-Percentile, Adult Male Dummy equipped with footwear is typically placed in the right-front seat of the test vehicle with the seat belt fastened. However, because the testing detailed herein was exploratory in nature and not MASH compliant, no dummy was installed in the vehicle for the testing.

5.5 Data Acquisition Systems

5.5.1.1 Accelerometers and Rate Transducers

The accelerometer and rate transducer systems used in the exploratory testing were the SLICE-1 and SLICE-2 units described below. Units were positioned near the c.g. of the test vehicle and the SLICE-1 unit was designated as primary. Data obtained in dynamic testing was filtered using the SAE Class 60 and the SAE Class 180 Butterworth filter conforming to the SAEJ211/1 specifications [12]

The SLICE-1 and SLICE-2 units were modular data acquisition systems manufactured by Diversified Technical Systems, Inc. of Seal Beach, California. Triaxial acceleration and angular rate sensor modules were mounted inside the bodies of custom-built SLICE 6DX event data recorders equipped with 7GB of non-volatile flash memory and recorded data at 10,000 Hz to the onboard microprocessor. The accelerometers had a range of $\pm 500g$'s in each of three directions (longitudinal, lateral, and vertical) and a 1,650 Hz (CFC 1000) anti-aliasing filter. The SLICE MICRO Triax ARS had a range of 1,500 degrees/sec in each of three directions (roll, pitch, and yaw). The raw angular rate measurements were downloaded, converted to the proper Euler angles for analysis, and plotted. The "SLICEWare" computer software program and a customized Microsoft Excel worksheet were used to analyze and plot both the accelerometer and angular rate sensor data.

5.5.1.2 Retroreflective Optic Speed Trap

A retroreflective optic speed trap was used to determine the speed of the test vehicle before impact. Five retroreflective targets, spaced at approximately 18-in. intervals, were applied to the side of the vehicle. When the emitted beam of light was reflected by the targets and returned to the Emitter/Receiver, a signal was sent to the data acquisition computer, recording at 10,000 Hz, as well as the external LED box activating the LED flashes. The speed was then calculated using the spacing between the retroreflective targets and the time between the signals. LED lights and high-speed digital video analysis are used as a backup if vehicle speeds cannot be determined from the electronic data.

5.5.1.3 Digital Photography

Three AOS high-speed digital video cameras, two GoPro digital video cameras, and four Panasonic digital video cameras were utilized to film test no. NMB-1. Camera details, camera operating speeds, lens information, and a schematic of the camera locations relative to the system are shown in Figure 32.

The high-speed videos were analyzed using TEMA Motion and Redlake MotionScope software programs. Actual camera speed and camera divergence factors were considered in the analysis of the high-speed videos. A digital still camera was also used to document pre- and post-test conditions for all tests.

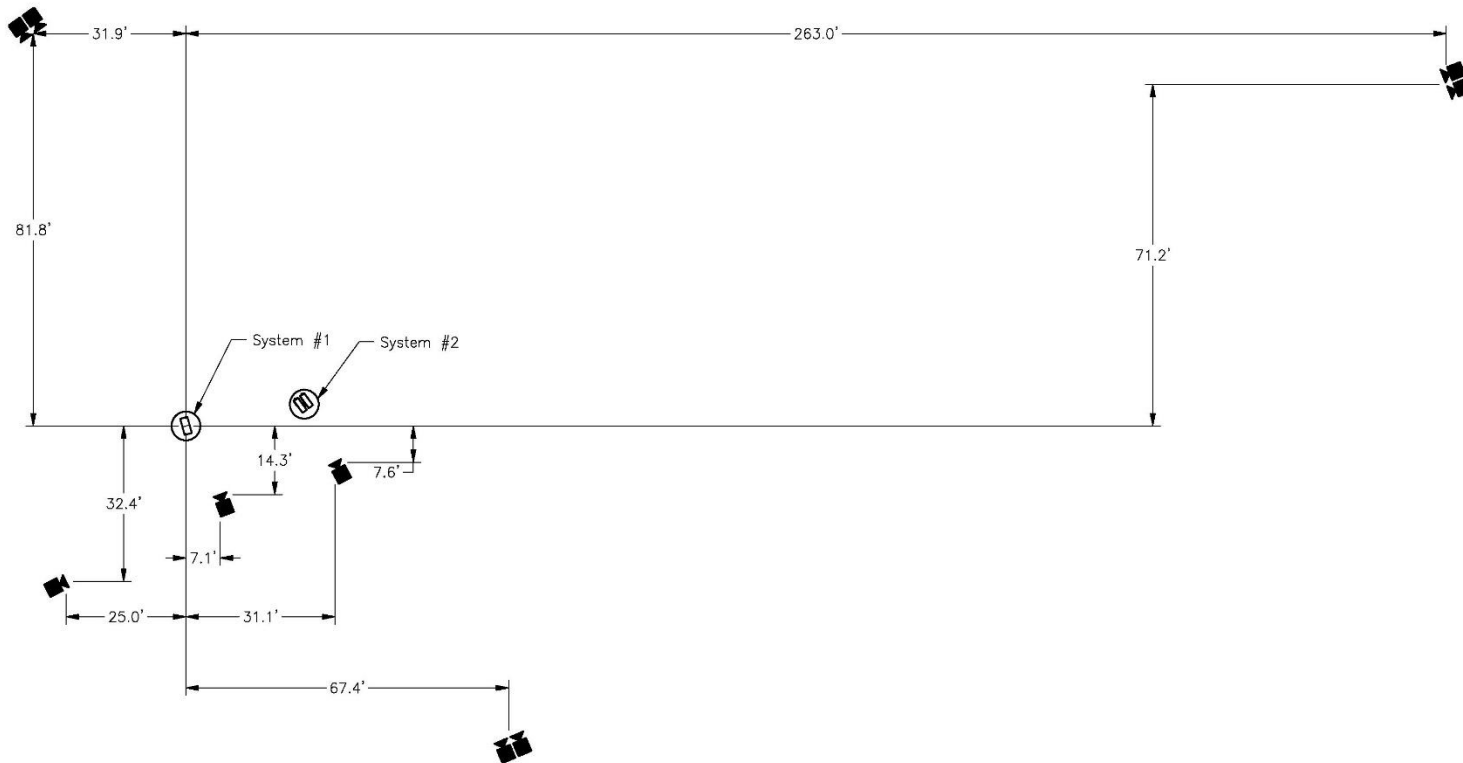

No.	Type	Operating Speed (frames/sec)	Lens	Lens Setting
AOS-5	AOS X-PRI Gigabit	500	100 mm	
AOS-11	AOS Vitcam CTM	500	17-50 at 35	
AOS-12	AOS Vitcam CTM	500	24-135 at 35	
GP-23	GoPro Hero 7	120		
GP-24	GoPro Hero 7	120		
PAN-2	Panasonic HC-V770	120		
PAN-4	Panasonic HC-V770	120		
PAN-5	Panasonic HC-V770	120		
PAN-6	Panasonic HC-V770	120		

Figure 32. Camera Locations, Speeds, and Lens Settings, Test No. NMB-1

6 DESIGN DETAILS

The single and dual PSST mailbox supports impacted in the dynamic component testing with a surrogate, non-compliant MASH 1100C vehicle are shown in Figures 33 through 43. Photographs of the test installation are shown in Figures 44 through 46. Material specifications, mill certifications, and certificates of conformity for the system materials are shown in Appendix B

The single mailbox support consisted of a 2¼-in. × 12-gauge PSST embedded stub and a 2-in. × 14-gauge PSST support post. The stub was 36 in. long and embedded 32 in. into the ground. The support post was socketed 6 in. inside the stub and was connected to the stub with a 5/16-in. diameter corner bolt. The mailbox mount consisted of a mounting plate and socket tube. The mounting plate consisted of a bent plate with side flanges and was fabricated from 14-gauge ASTM 1011 Grade 50 steel. Holes and slots were fabricated through the mounting plate to accommodate various mailbox side flange and base attachment options. The mounting plate was welded to a 2½-in. x 2½-in. x 3/16-in. A512 Grade B steel tube that socketed over the support post and was held in place by a 5/16-in. diameter corner bolt. Four ¼-in. diameter SAE J429 Grade 5 bolts were used to attach the mounting bracket to the base of the mailbox. A Gibraltar Northpointe Post Mount Mailbox (Model #NM160V01) made from galvanized steel was attached to the mailbox support. The mailbox weight was 10.2 lb.

The dual mailbox support used the same stub and support post as the single mailbox support concept but modified the mailbox mounting bracket to accommodate two mailboxes. A TAPCO dual mailbox mount kit (Part no. 034-00045) was used to mount the dual mailboxes to the support post. The kit contained a pair of two-piece, adjustable, 16-gauge mounting brackets and a 14-gauge flat plate bracket. The TAPCO mounting kit supplied 5/16-in. diameter spade bolts and a 5/16-in. diameter hex bolt that were compatible for attachment of the flat plate bracket to the 2-in. square PSST support post. The adjustable mailbox brackets were bolted to the flat plate bracket with 5/16-in. truss head machine screws. The mounting bolts for attachment of the mailbox to the mounting brackets were upgraded to ¼-in. diameter SAE Grade 5 hardware to mitigate concerns for mailbox detachment. A Gibraltar Elite Post Mount Mailbox (Model #E1100B00) made from galvanized steel was attached to each mailbox mounting bracket. The mailbox weight was 4.6 lb.

Both mailbox supports were imbedded 32 in. into a compacted, coarse, crushed limestone material, alternatively classified as well-graded gravel by the Unified Soil Classification System that met American Association of State Highway and Transportation Officials (AASHTO) standard soil designation M147 Grade B. The second mailbox was placed 25 feet downstream and with an offset equal to one half the vehicle's width from the first mailbox, as shown in Figure 33.

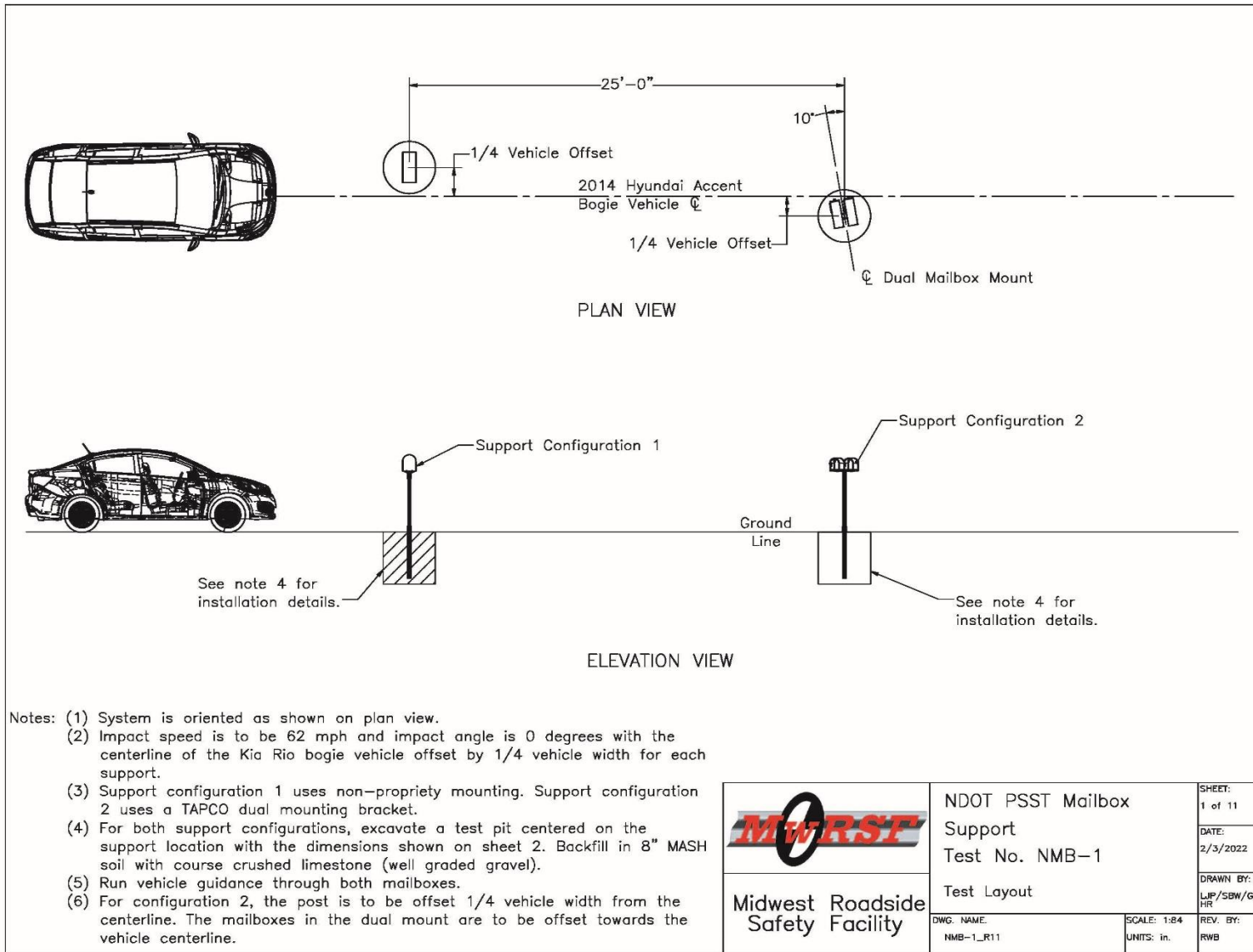

Figure 33. Test Installation Layout, Test No. NMB-1

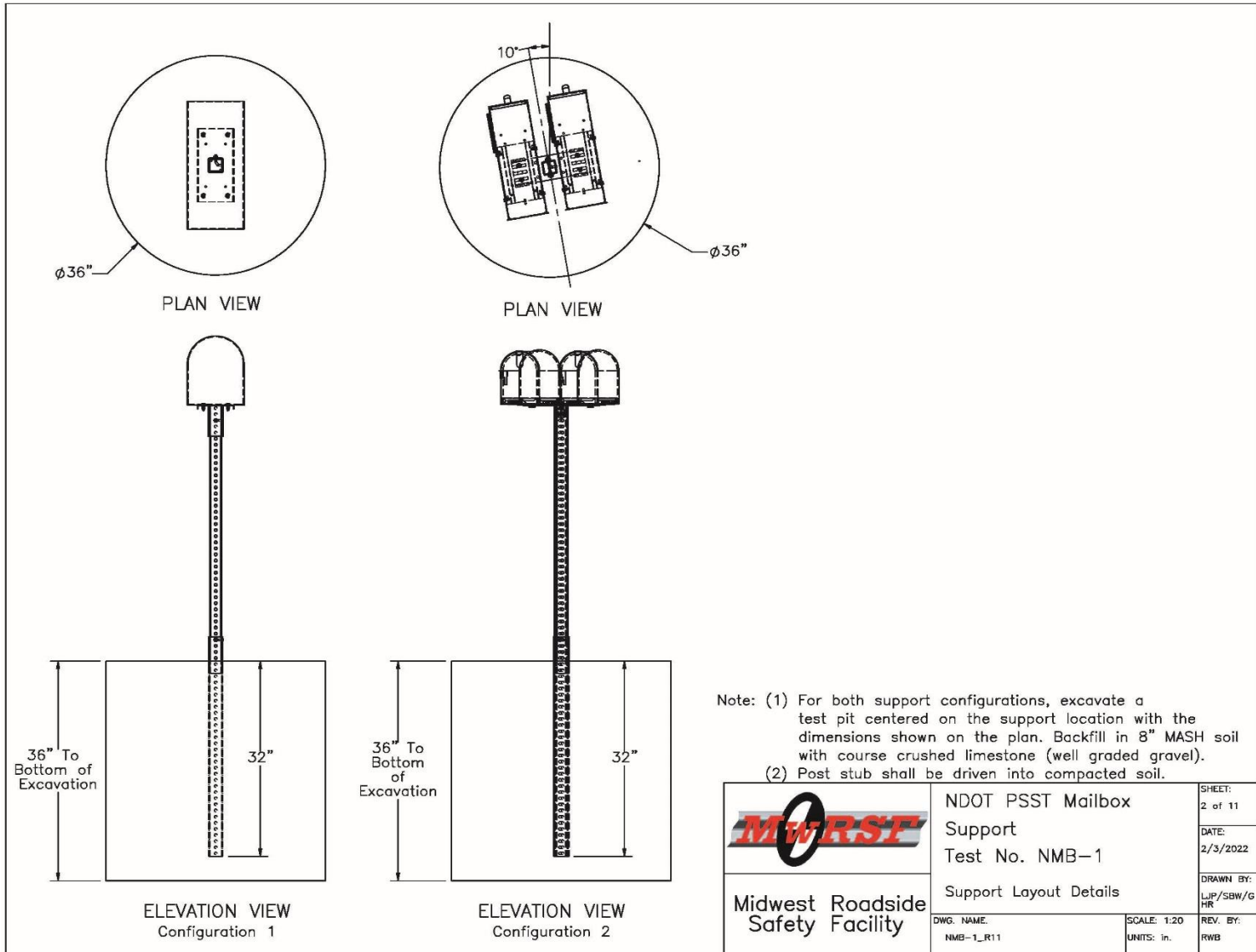

Figure 34. Support Layout Details, Test No. NMB-1

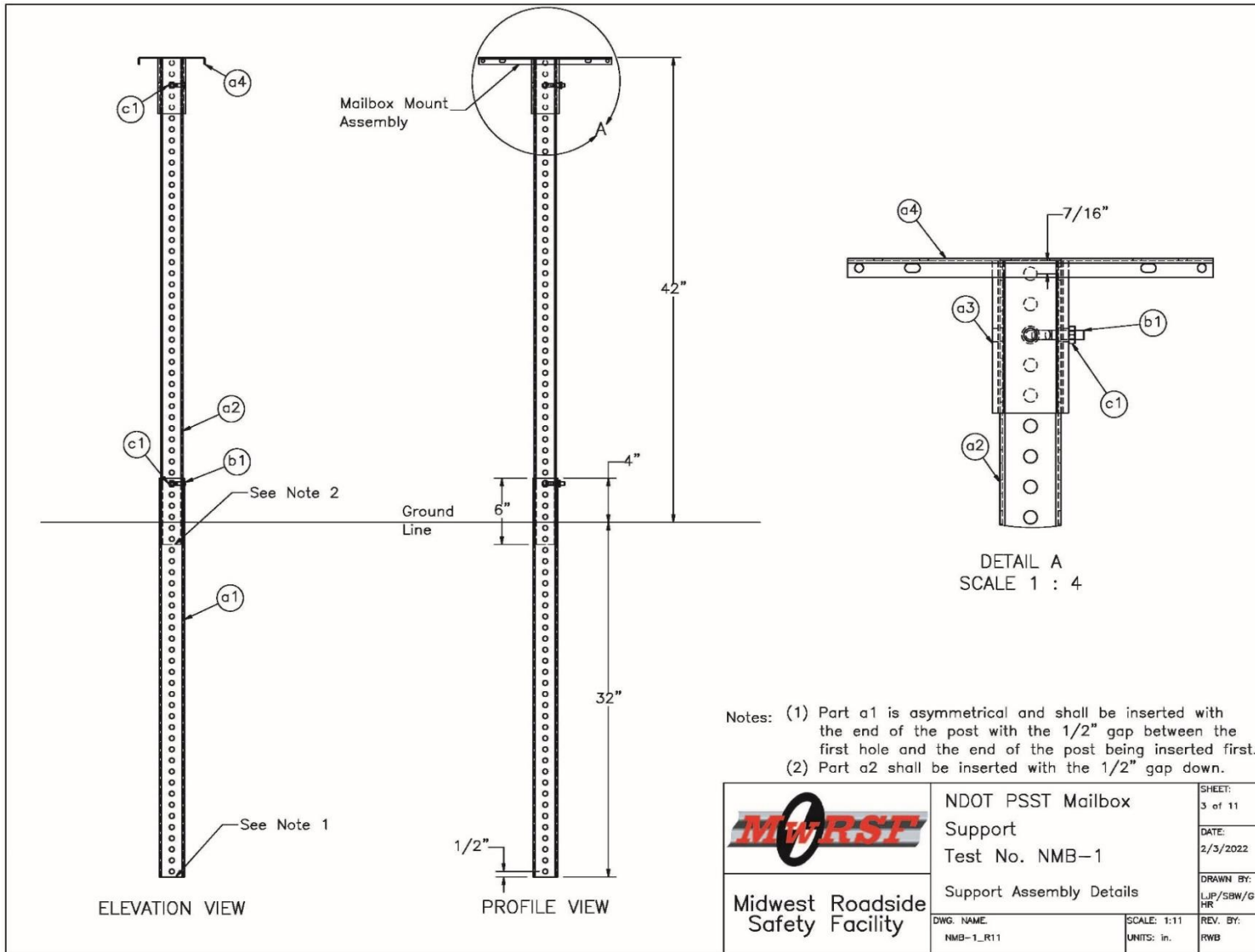

Figure 35. Support Assembly Details, Test No. NMB-1

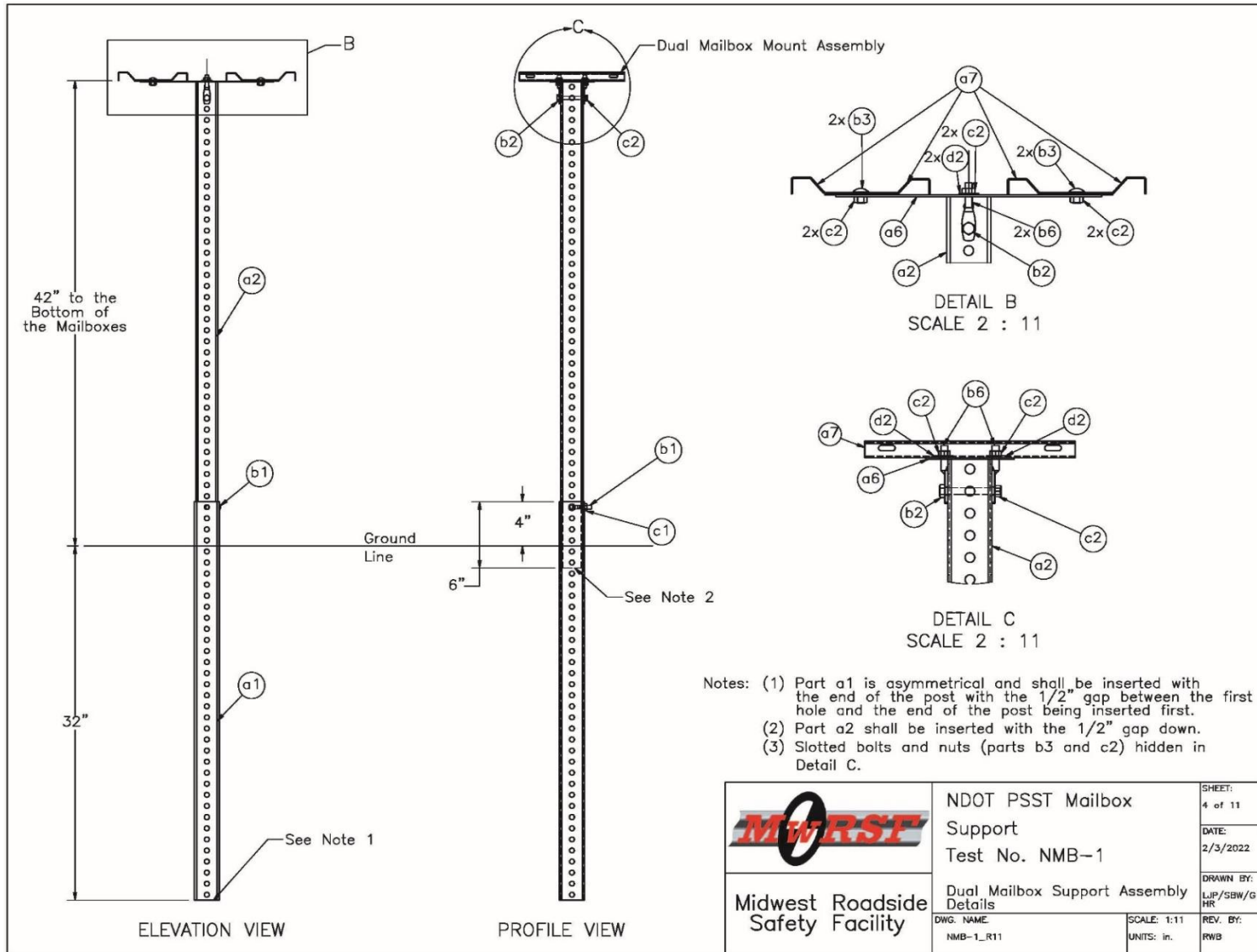

Figure 36. Dual Mailbox Support Assembly Details, Test No. NMB-1

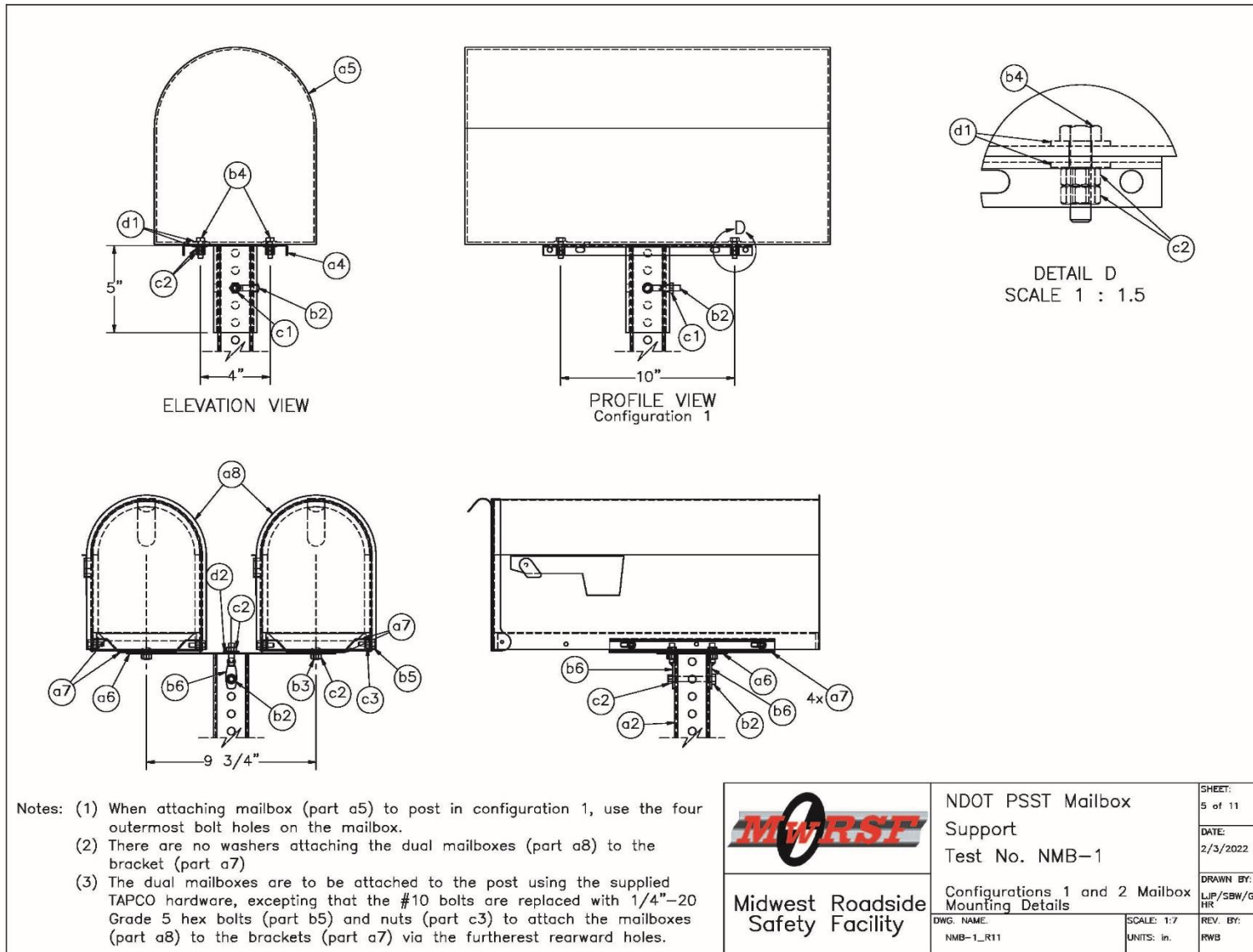

Figure 37. Configurations 1 and 2 Mailbox Mounting Details, Test No. NMB-1

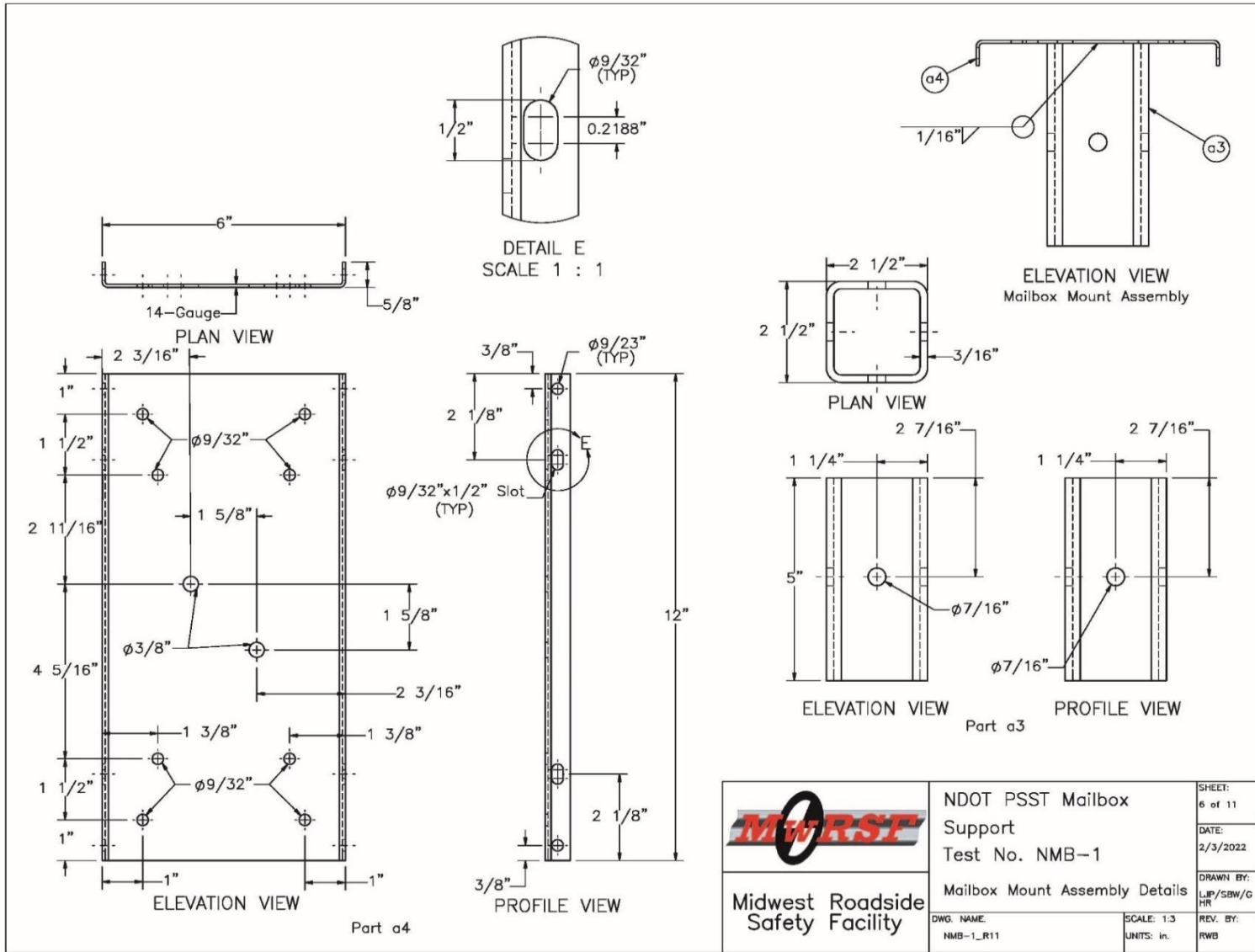

Figure 38. Mailbox Mount Assembly Details, Test No. NMB-1

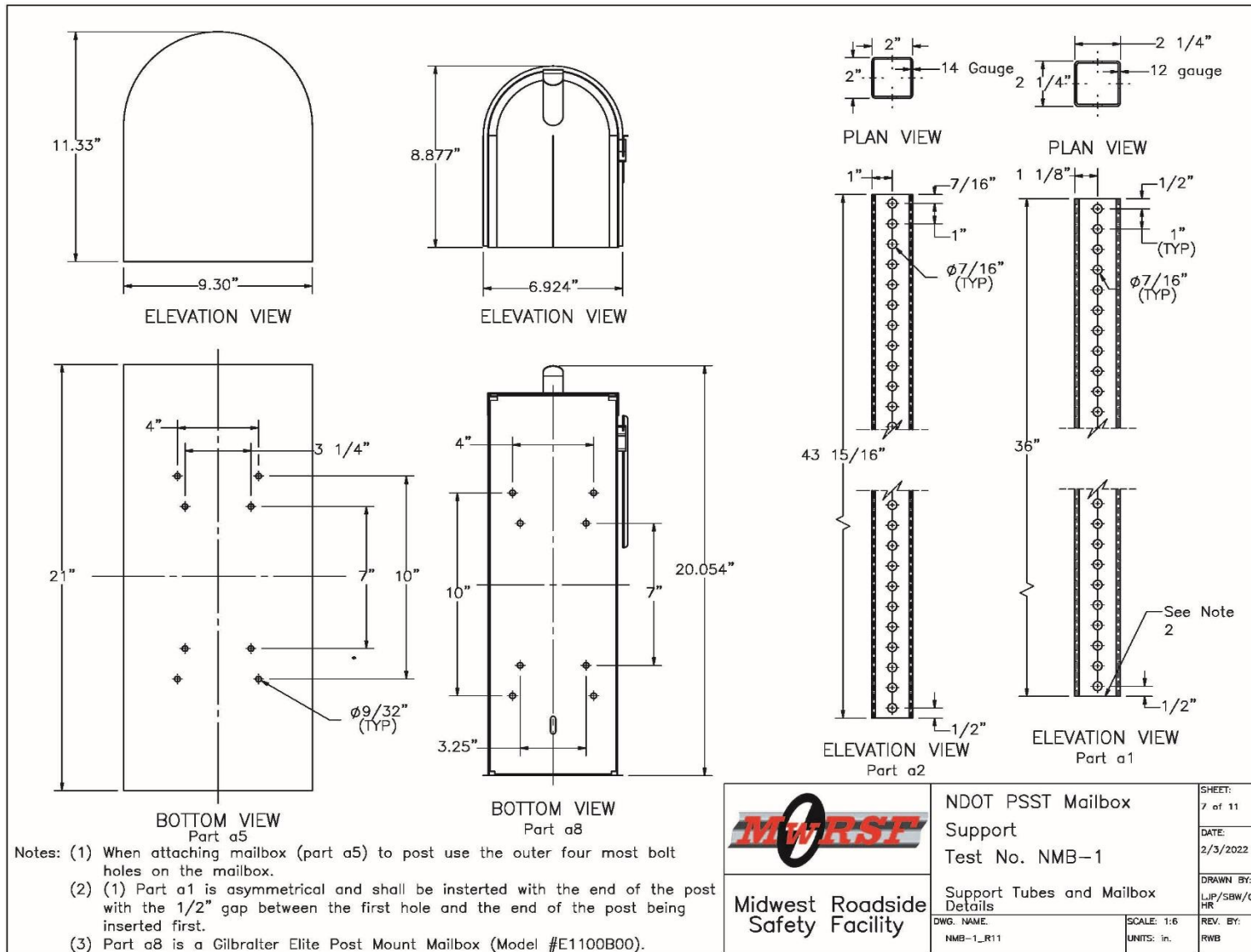

Figure 39. Support Tubes and Mailbox Details, Test No. NMB-1

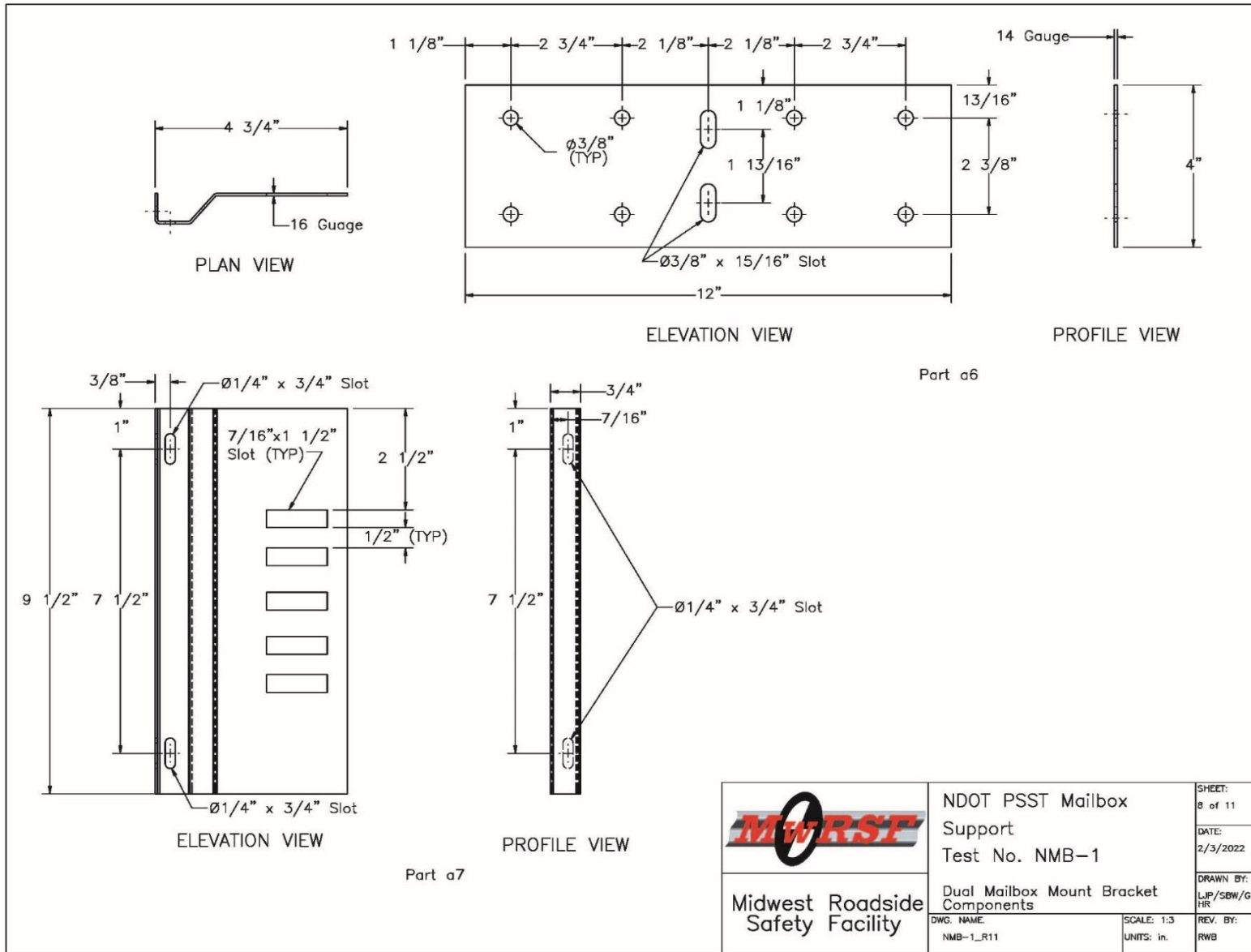

Figure 40. Dual Mailbox Mount Bracket Components, Test No. NMB-1

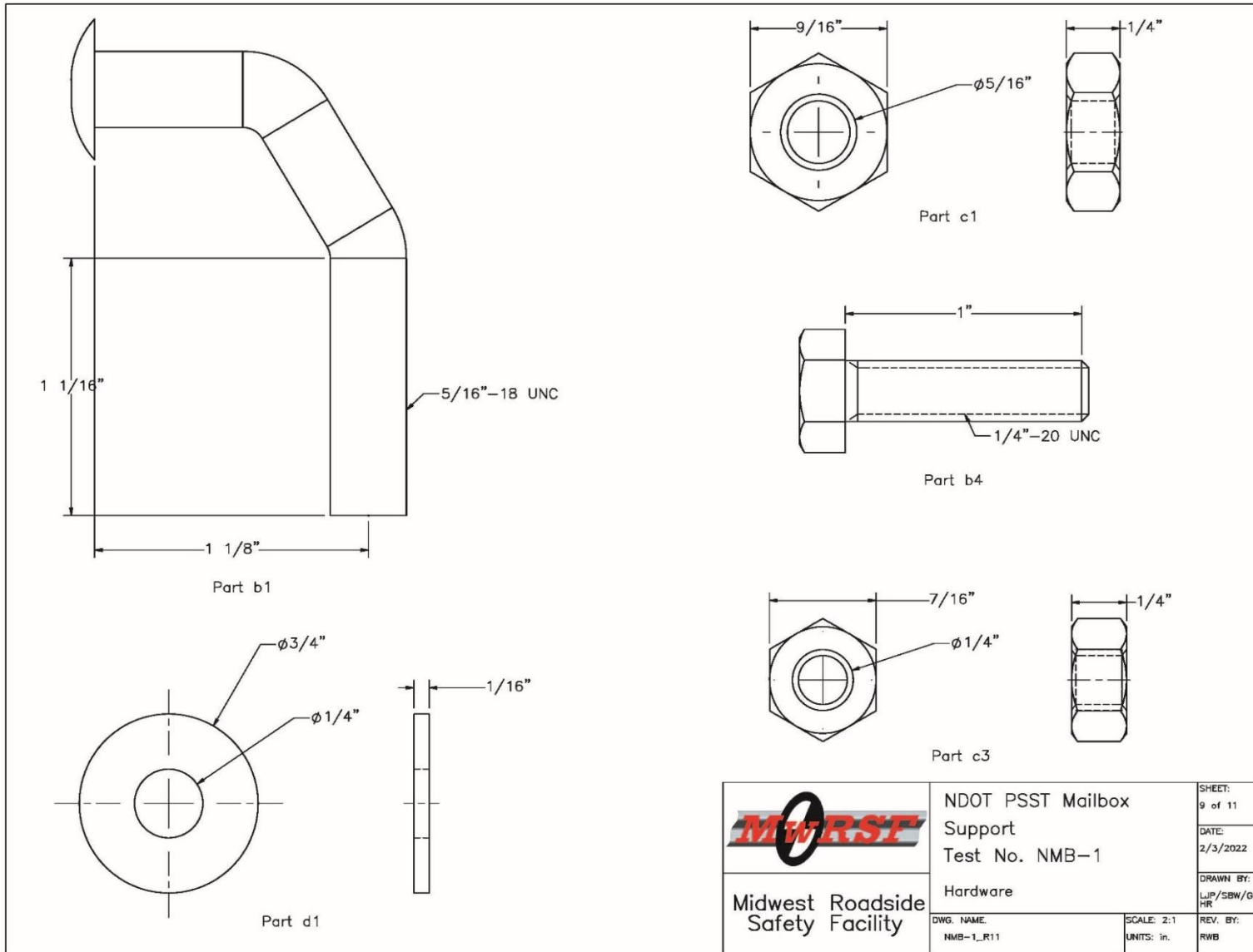

Figure 41. Hardware, Test No. NMB-1

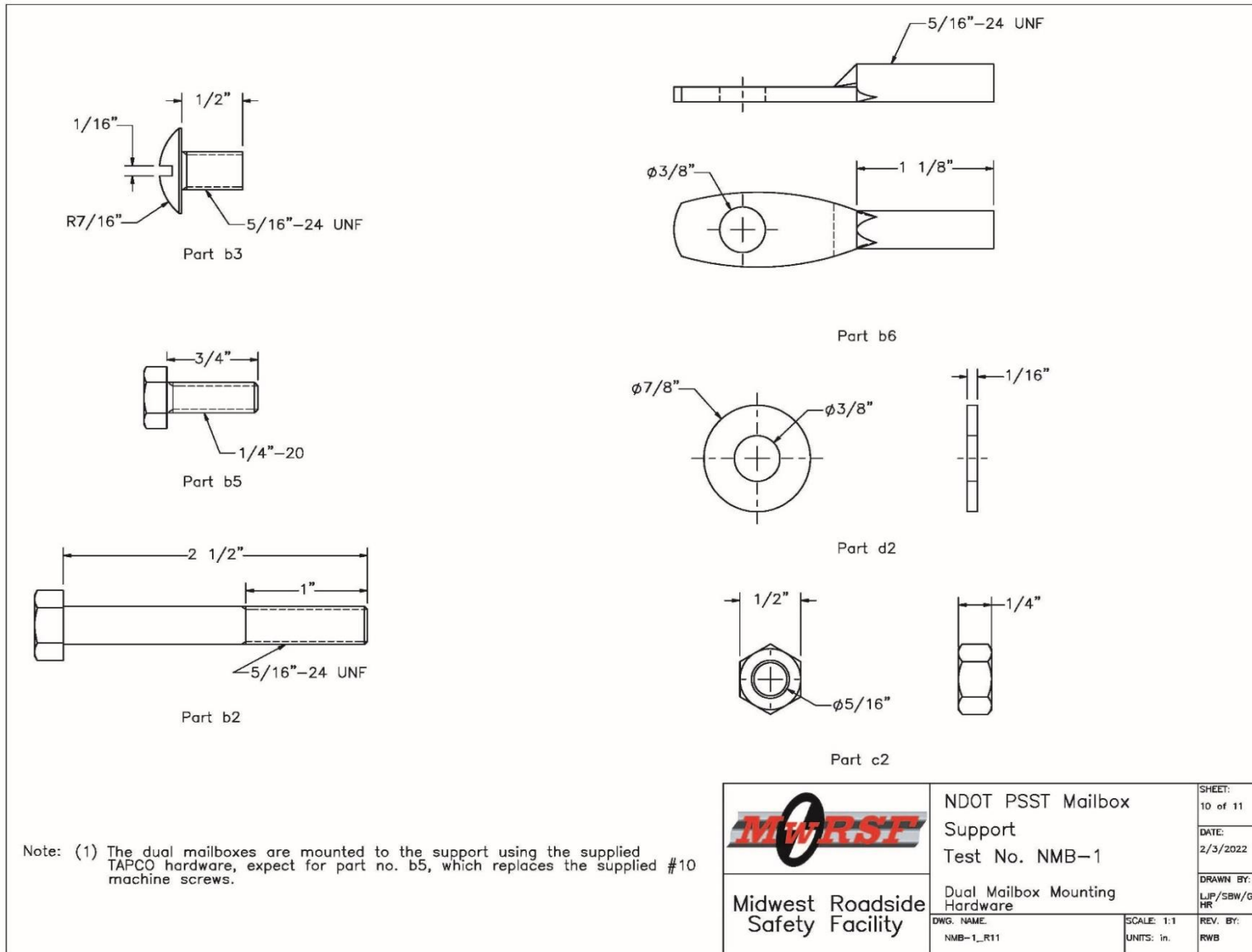

Figure 42. Dual Mailbox Mounting Hardware, Test No. NMB-1

Item No.	QTY.	Description	Material Specification	Treatment Specification	Hardware Guide
–	1	MASH Strong Soil	–	–	–
a1	2	Telespar PSST 2 1/4"x2 1/4"x12 gauge	ASTM A1011 Grade 50	ASTM A653	–
a2	2	Telespar PSST 2"x2"x14 gauge	ASTM A1011 Grade 50	ASTM A653	–
a3	1	2 1/2"x2 1/2"x3/16" Square Tube	ASTM A513 (yield=50 ksi min) or ASTM A500 Grade B	ASTM A123	–
a4	1	PSST Mailbox Support Mounting Plate	ASTM A1011 Grade 50	ASTM A123	–
a5	1	Gibraltar Northpointe Post Mount Mailbox	Galvanized Steel – Model #NM160V01	–	–
a6*	1	TAPCO Channel Bracket	14 gauge Plate Steel – Type Unspecified	Galvanized – Unspecified	–
a7*	4	TAPCO Mount Bracket Half	16 gauge Sheet Steel – Type Unspecified	Galvanized – Unspecified	–
a8**	2	Gibraltar Elite Post Mount Mailbox	Galvanized Steel – Model #E1100B00	–	–
b1	3	5/16"–18 Corner Bolt for 2 1/4" PSST	SAE J429 Grade 2	ASTM A153 or B695 Class 55 or F1941 or F2329	–
b2*	1	TAPCO 5/16"–24 UNF x 2 1/2" Hex Bolt	Unspecified Steel	Galvanized – Unspecified	–
b3*	4	TAPCO 5/16"–24 UNF x 1/2" Truss Head Machine Screw	Unspecified Steel	Zinc Plated	–
b4	4	1/4"–20 UNC x 1" Hex Bolt	SAE J429 Grade 5	ASTM A153 or B695 Class 55 or F1941 or F2329	–
b5	8	1/4"–20 x 3/4" Hex Bolt	SAE Grade 5	–	–
b6*	2	TAPCO 5/16"–24 UNF x2.5" Spade Bolt	Unspecified Steel	Zinc Plated	–
c1	3	5/16"–18 Heavy Hex Jam Nut	SAE Grade 2	ASTM A153 or B695 Class 55 or F1941 or F2329	–
c2*	7	TAPCO 5/16"–24 Hex Lock Nut	Unspecified Steel with Nylon Insert	Zinc Plated	–
c3	16	1/4"–20 UNC Hex Nut	SAE J995 Grade 5	ASTM A153 or B695 Class 55 or F1941 or F2329	–
d1	8	1/4" Dia. Plain Round Washer	SAE Grade 5	ASTM A153 or B695 Class 55 or F1941 or F2329	–
d2*	2	TAPCO 5/16" Dia. Plain Round Washer	Unspecified Steel	Zinc Plated	–

Notes: (*) Parts supplied from the TAPCO dual mount kit (Part no. 034–00045). (**) Mailboxes chosen to meet NDOT requirements for 5 lb. mailboxes.	 Midwest Roadside Safety Facility	NDOT PSST Mailbox Support Test No. NMB–1	SHEET: 11 of 11
		Bill of Materials	DATE: 2/3/2022
	DWG. NAME: NMB–1_R11	SCALE: None UNITS: in.	DRAWN BY: LJP/SBW/G HR
			REV BY: RWB

Figure 43. Bill of Materials, Test No. NMB-1



Figure 44. Test Installation Photographs, Test No. NMB-1



Figure 45. Test Installation Photographs, Test No. NMB-1



Figure 46. Test Installation Photographs, Test No. NMB-1

7 COMPONENT TEST NO. NMB-1 (NMB-1A AND NMB-1B)

7.1 Weather Conditions

Test no. NMB-1 was conducted on March 21, 2022 at approximately 2:30 p.m. The weather conditions as reported by the National Oceanic and Atmospheric Administration (station 14939/KLNK) are shown in Table 14.

Table 14. Weather Conditions, Test No. NMB-1

Temperature	59°F
Humidity	49%
Wind Speed	20 mph
Wind Direction	170° from True North
Sky Conditions	Sunny
Visibility	10 Statute Miles
Pavement Surface	Dry
Previous 3-Day Precipitation	0.36 in.
Previous 7-Day Precipitation	0.71 in.

7.2 Test Description

Test no. NMB-1 was conducted as a dynamic component test to explore the performance of two prototype PSST mailbox supports. The test was conducted using a surrogate, non-compliant, MASH 1100C vehicle that impacted two mailbox supports in a single vehicle pass. The first mailbox support impact (single mailbox support) was identified as test no. NMB-1A, and the second mailbox support impact (dual mailbox support) was identified as test no. NMB-1B. The two mailbox supports were offset longitudinally by 25 ft and were offset laterally to allow impact on opposing quarter points of the test vehicle, as shown in Figure 47.

In test no. NMB-1A, the 2,471-lb small car impacted the single mailbox support at a speed of 63.7 mph and an angle of 0 degrees with a ¼ offset toward the left side of the vehicle. During the impact, the PSST support post wrapped around the front of the vehicle which pulled the mailbox down toward the hood. The mailbox impacted near the front of the hood at approximately 0.020 sec after initial impact. Impact with the vehicle hood caused the mailbox to detach at three of the four bolt locations on the base of the mailbox due to the bolts pulling through the base of the mailbox. The bolts remained intact and attached to the mounting plate. The PSST post separated from the embedded stub due to fracture of the corner bolt near the base of the post. After the post was released, the mailbox and post were propelled downstream in front of the 1100C vehicle. No contact with the windshield or deformation or penetration of the occupant compartment were observed due to contact with the mailbox. The vehicle continued downstream toward the second mailbox support installation.

In test no. NMB-1B, the 2,471-lb small car impacted the dual mailbox support at a speed of 61.1 mph and an angle of 10 degrees with a ¼ offset toward the right side of the vehicle. During the impact, the PSST support post wrapped around the front of the vehicle which pulled the

mailbox down toward the hood. The mailboxes impacted the upper third of the hood at 0.022 sec after initial impact. The PSST did not separate from the embedded stub in this impact, but partial fracture of the PSST post was noted near the stub socket. Without post release from the stub, the post was pulled down beneath the vehicle. This motion generated sufficient load to fracture the spade bolts connecting the TAPCO mounting assembly to the top of the PSST post. Fracture of the spade bolts released the mailboxes and TAPCO mounting bracket from the PSST at 0.040 sec after impact. After the mailboxes released, the mailbox and mounting bracket were propelled up and to the side of the 1100C vehicle with little to no relative velocity toward the windshield. The vehicle continued downstream and overrode the PSST support post and stub. No contact with the windshield or deformation or penetration of the occupant compartment were observed due to contact with the mailbox.

A detailed description of the sequential impact events is contained in Tables 15 and 16. Sequential photographs are shown in Figures 48 through 50. The vehicle trajectory and final position are shown in Figure 51.



Figure 47. Target Impact Location, Test No. NMB-1

Table 15. Sequential Description of Impact Events, Test No. NMB-1A

Time (sec)	Event
0.000	Vehicle's front bumper contacted System 1 post and deformed.
0.008	System 1 post bent and buckled towards the vehicle's hood.
0.020	Vehicle's hood contacted System 1 and deformed.
0.046	System 1 post disengaged from anchor sleeve.
0.060	System 1 became airborne.
0.590	System 1 contacted ground.

Table 16. Sequential Description of Impact Events, Test No. NMB-1B

Time (sec)	Event
0.000	Vehicle' s front bumper contacted System 2 post and deformed and stripped right side of bumper.
0.006	Vehicle's hood and right fender contacted System 2 and deformed. System 2 post bent and buckled toward vehicle's hood.
0.012	Vehicle's right headlight contacted System 2 post and fractured.
0.040	System 2 mailboxes disengaged from post.
0.104	System 2 mailboxes became airborne.
1.183	System 2 mailboxes contacted ground.



0.000 sec



0.030 sec



0.060 sec



0.090 sec



0.120 sec

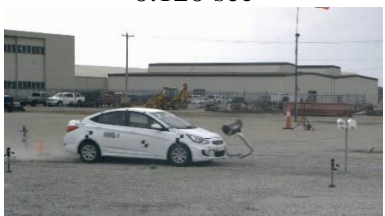

0.150 sec

Test No. NMB-1A



0.000 sec



0.030 sec

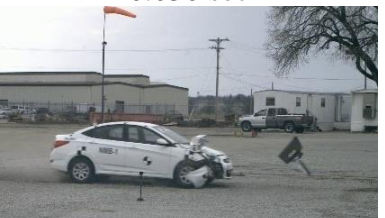

0.060 sec



0.090 sec

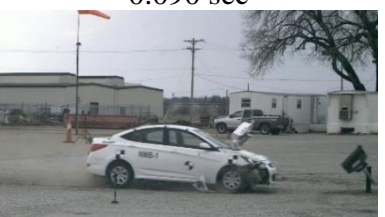

0.120 sec



0.150 sec

Test No. NMB-1B

Figure 48. Sequential Photographs, Test No. NMB-1



0.000 sec



0.030 sec



0.060 sec



0.090 sec



0.120 sec



0.150 sec



0.000 sec



0.030 sec



0.060 sec



0.090 sec



0.120 sec



0.150 sec

Figure 49. Sequential Photographs, Test No. NMB-1A



0.000 sec



0.030 sec



0.060 sec



0.090 sec



0.120 sec



0.150 sec



0.000 sec



0.040 sec



0.080 sec



0.120 sec



0.160 sec



0.200 sec

Figure 50. Sequential Photographs, Test No. NMB-1B



Figure 51. Vehicle Final Position and Trajectory Marks, Test No. NMB-1

7.3 System Damage

Damage to System A, the single mailbox support, was extensive, as shown in Figures 52 and 53. The embedded stub of the mailbox support was displaced several inches through the soil and was bent near the groundline. The corner bolt connecting the stub to the mailbox support post fractured and the support post pulled out of the embedded stub. The single mailbox in System A was completely detached from the support post and mounting bracket due to the mounting bolts being pulled through the base of the mailbox. Note that review of the high-speed video found that three of the bolts detached during the initial vehicle impact. It is likely that the final bolt pulled through the base of the mailbox due to secondary impact with the ground. The mailbox was severely deformed and had fractured at several spotwelds holding the sections of the mailbox together. The support post was kinked and bent at two locations midway along its length. The mounting bracket remained attached to the top of the support post. All the mailbox attachment bolts were intact and remained attached to the mounting plate.

Damage to System B, the dual mailbox support, was extensive, as shown in Figures 54 and 55. The embedded stub of the mailbox support was displaced several inches through the soil and was bent near the groundline. The mailbox support post remained connected to the embedded stub and the corner bolt connecting the stub and support post remained intact. The mailbox support post was kinked and bent at a location midway along its length and was partially fractured where it was inserted into the stub. The dual mailboxes in System B were completely detached from the support post due to fracture of both spade bolts connecting the support post to the TAPCO mounting bracket. Both mailboxes remained attached to the TAPCO mounting bracket. The flat plate portion of the bracket and the adjustable brackets remained attached to each other and the mailboxes, but the mounting bracket hardware was deformed during impact. The mailbox nearest to the vehicle at impact was severely deformed. The rear mailbox was deformed as well, but the extent of the deformation was significantly less. All mailbox attachment bolts were intact and remained attached.



Figure 52. System Damage, Test No. NMB-1A



Figure 53. System Damage, Test No. NMB-1A

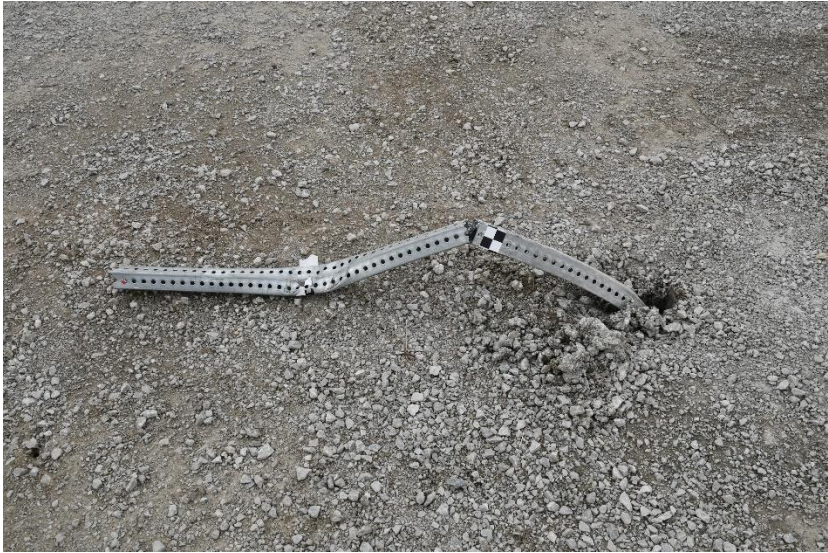

Figure 54. System Damage, Test No. NMB-1B



Figure 55. System Damage, Test No. NMB-1B

7.4 Vehicle Damage

The surrogate, reusable, 1100C test vehicle sustained moderate damage, as shown in Figure 56. Damage consisted of minor deformation and contact marks at the left ¼ point of the front bumper where impact occurred. The right ¼ point of the front bumper sustained more damage as the right quarter of the bumper cover was disengaged, along with minor deformation of the bumper structure, and fracture of the right headlight cover. Indentation was visible on both sides of the vehicle hood due to contact with the mailboxes. No damage was observed to the windshield or roof of the vehicle. Occupant compartment deformations were not formally measured for this non-compliant test with a surrogate vehicle. While undercarriage contact with the System B mailbox support occurred, no visible occupant compartment deformations were observed.



Figure 56. Vehicle Damage Test No. NMB-1

7.5 Occupant Risk

The calculated occupant impact velocities (OIVs) and maximum 0.010-sec average occupant ridedown accelerations (ORAs) in both the longitudinal and lateral directions, as determined from the accelerometer data for test nos. NMB-1A and test no. NMB-1B, are shown in Tables 17 and 18, respectively. Note that the OIVs and ORAs were within suggested limits, as provided in MASH. The calculated THIV, PHD, and ASI values are also shown in tables 17 and 18. Note that the mailbox impacts were not sufficient to trigger an occupant impact with the interior of the vehicle according to the flail space model used to determine occupant risk. Thus, no ORA or PHD values were determined for the event. The OIV values listed correspond to the change in velocity of the test vehicle after the vehicle lost contact with the test article and/or the rear of the vehicle passed over the stub of the support. The recorded data from the accelerometers and the rate transducers is shown graphically in Table 17.

Table 17. Summary of OIV, ORA, THIV, PHD, and ASI Values, Test No. NMB-1A

Evaluation Criteria		Transducer data		MASH 2016 Limits
		SLICE-1 (primary)	SLICE-2	
OIV ft/s	Longitudinal	-3.69	-3.63	±40
	Lateral	0.46	0.52	±40
ORA g's	Longitudinal	N/A	N/A	±20.49
	Lateral	N/A	N/A	±20.49
Maximum Angular Displacement deg.	Roll	1.05	1.30	±75
	Pitch	-0.64	-0.90	±75
	Yaw	-1.47	-1.58	not required
THIV – ft/s		0	0	not required
PHD – g's		N/A	N/A	not required
ASI		0.20	0.26	not required

Table 18. Summary of OIV, ORA, THIV, PHD, and ASI Values, Test No. NMB-1B

Evaluation Criteria		Transducer data		MASH 2016 Limits
		SLICE-1 (primary)	SLICE-2	
OIV ft/s	Longitudinal	-3.12	-3.09	±40
	Lateral	0.52	0.15	±40
ORA g's	Longitudinal	N/A	N/A	±20.49
	Lateral	N/A	N/A	±20.49
Maximum Angular Displacement deg.	Roll	-2.10	-2.64	±75
	Pitch	-1.14	-1.23	±75
	Yaw	4.58	4.53	not required
THIV – ft/s		0	0	not required
PHD – g's		N/A	N/A	not required
ASI		0.15	0.15	not required

7.6 Discussion

The analysis of the test results for test no. NMB-1 showed that both the prototype single and dual mailbox systems had the potential to meet MASH TL-3. A summary of the test results and sequential photographs are shown in Figures 57 and 58.

In test no. NMB-1A, detached elements, fragments, or other debris from the test article did not penetrate or show potential for penetrating the occupant compartment, or present an undue hazard to other traffic, pedestrians, or work-zone personnel. Deformations of, or intrusions into, the occupant compartment that could have caused serious injury were not observed, but it should be noted that formal occupant compartment measurements were not recorded. Vehicle roll, pitch, and yaw angular displacements were deemed acceptable because they did not adversely influence occupant risk nor cause rollover. Occupant risk values were within the MASH limits. Therefore, test no. NMB-1A indicated that the performance of the PSST single mailbox support had the potential to be acceptable according to the MASH safety performance criteria for test designation no. 3-61.

In test no. NMB-1B, detached elements, fragments, or other debris from the test article did not penetrate or show potential for penetrating the occupant compartment, or present an undue hazard to other traffic, pedestrians, or work-zone personnel. Deformations of, or intrusions into, the occupant compartment that could have caused serious injury were not observed, but it should be noted that formal occupant compartment measurements were not recorded. Vehicle roll, pitch, and yaw angular displacements were deemed acceptable because they did not adversely influence occupant risk nor cause rollover. Occupant risk values were within the MASH limits. Therefore, test no. NMB-1B indicated that the performance of the PSST dual mailbox support had the potential to be acceptable according to the MASH safety performance criteria for test designation no. 3-61.

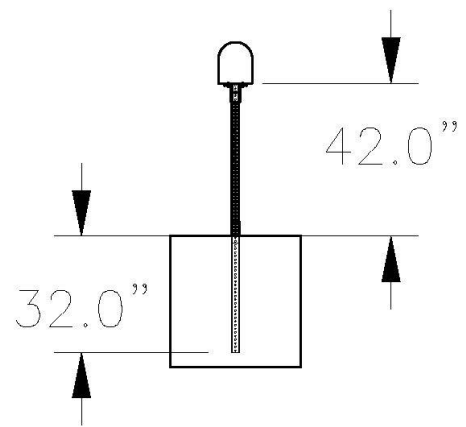
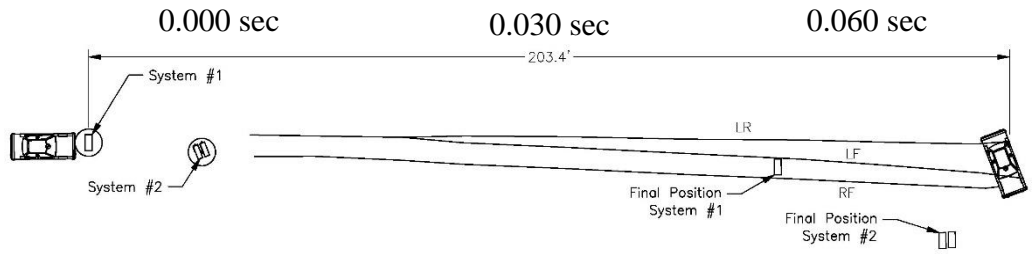

- Test AgencyMwRSF
- Test Number..... NMB-1A
- Date 03/21/2022
- MASH 2016 Test Designation No..... 3-61 (Non-Compliant)
- Test Article..... PSST Single Mailbox Support
- Key Component – PSST Support
 - Stub..... 2¼-in. × 12-gauge PSST
 - Mast..... 2-in. × 14-gauge PSST
 - Height to Bottom of Mailbox..... 42 in.
- Key Component – Mailbox
 - Length..... 21 in.
 - Width..... 9.3 in.
 - Height..... 11.3 in.
 - Weight..... 10.2 lb
 - Model Gibraltar Northpointe Post Mount Mailbox (Model #NM160V01)
- Soil TypeMASH Strong Soil (Well-Graded Gravel)
- Vehicle Make /Model 2014 Hyundai Accent
 - Curb..... 2,519 lb
 - Test Inertial 2,471 lb
 - Gross Static 2,471 lb
- Impact Conditions
 - Speed 63.7 mph
 - Angle 0 deg.
 - Impact Location Left ¼ Point of Front Bumper
- Impact Severity/Kinetic Energy 335.2 kip-ft > 286.1 kip-ft MASH limit
- Exit Conditions
 - Speed 61.2 mph
 - Angle -1.47 deg.
- Vehicle Stability..... Satisfactory
- Vehicle Stopping Distance N/A
- Vehicle Damage..... Minimal
 - VDS [15] N/A
 - CDC [16] N/A
 - Maximum Interior Deformation N/A

89

- Test Article Damage Extensive
- Transducer Data

Evaluation Criteria		Transducer		MASH 2016 Limits
		SLICE-1 (primary)	SLICE-2	
OIV ft/s	Longitudinal	-3.69	-3.63	±40
	Lateral	0.46	0.52	±40
ORA g's	Longitudinal	N/A	N/A	±20.49
	Lateral	N/A	N/A	±20.49
Maximum Angular Displacement deg.	Roll	1.05	1.30	±75
	Pitch	-0.64	-0.90	±75
	Yaw	-1.47	-1.58	not required
THIV – ft/s		0	0	not required
PHD – g's		N/A	N/A	not required
ASI		0.20	0.26	not required

Figure 57. Summary of Test Results and Sequential Photographs, Test No. NMB-1A

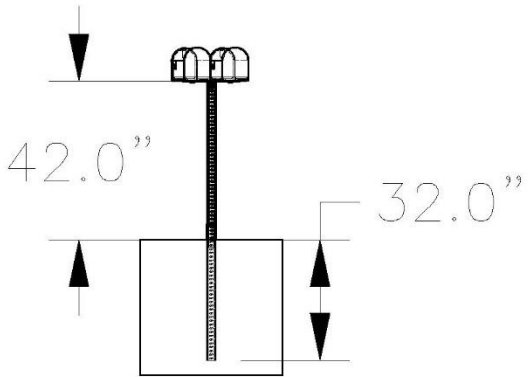
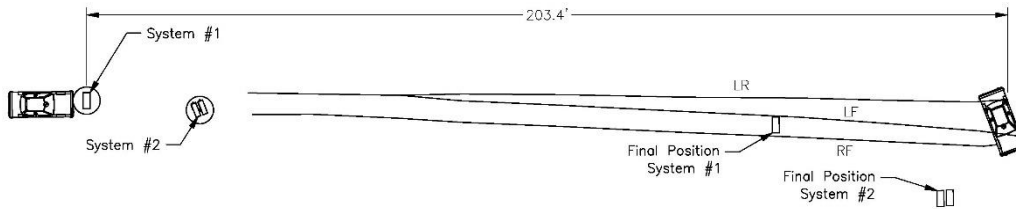

- Test AgencyMwRSF
- Test Number..... NMB-1B
- Date 03/21/2022
- MASH 2016 Test Designation No..... 3-61 (Non-Compliant)
- Test Article.....PSST Dual Mailbox Support
- Key Component – PSST Support
 - Stub..... 2¼-in. × 12-gauge PSST
 - Mast..... 2-in. × 14-gauge PSST
 - Height to Bottom of Mailbox..... 42 in.
- Key Component – Mailbox
 - Length..... 20.1 in.
 - Width..... 6.9 in.
 - Height..... 8.9 in.
 - Weight..... 4.6 lb
 - Model..... Gibraltar Elite Post Mount Mailbox (Model #E1100B00)
- Soil Type.....MASH Strong Soil (Well-Graded Gravel)
- Vehicle Make /Model 2014 Hyundai Accent
 - Curb..... 2,519 lb
 - Test Inertial 2,471 lb
 - Gross Static 2,471 lb
- Impact Conditions
 - Speed 61.1 mph
 - Angle 10 deg.
 - Impact Location Right ¼ Point of Front Bumper
- Impact Severity/Kinetic Energy 308.4 kip-ft > 286.1 kip-ft MASH limit
- Exit Conditions
 - Speed 59.0 mph
 - Angle 4.6 deg.
- Vehicle Stability..... Satisfactory
- Vehicle Stopping Distance N/A
- Vehicle Damage.....Minimal
 - VDS [15] N/A
 - CDC [16]..... N/A
 - Maximum Interior Deformation N/A

- Test Article Damage Extensive
- Transducer Data

Evaluation Criteria		Transducer		MASH 2016 Limits
		SLICE-1 (primary)	SLICE-2	
OIV ft/s	Longitudinal	-3.12	-3.09	±40
	Lateral	0.52	0.15	±40
ORA g's	Longitudinal	N/A	N/A	±20.49
	Lateral	N/A	N/A	±20.49
Maximum Angular Displacement deg.	Roll	-2.10	-2.64	±75
	Pitch	-1.14	-1.23	±75
	Yaw	4.58	4.53	not required
THIV – ft/s		0	0	not required
PHD – g's		N/A	N/A	not required
ASI		0.15	0.15	not required

90

Figure 58. Summary of Test Results and Sequential Photographs, Test No. NMB-1B

8 ADDITIONAL TEST ANALYSIS AND DISCUSSION

Following test no. NMB-1, the researchers reviewed the test results in detail and noted the following observations.

1. Both PSST single and dual mailbox support prototypes demonstrated the potential to meet MASH TL-3 test designation no. 3-61 safety requirements as occupant risk values were within limits and no occupant compartment violations were observed. It should be noted that these tests were run with a non-compliant, surrogate 1100C vehicle, and not all standard MASH full-scale test procedures and documentation were conducted during the test. As such, test nos. NMB-1A and NMB-1B were not considered compliant MASH tests. However, the performance of the mailbox supports evaluated in these tests is potentially indicative of their performance in a MASH compliant test designation no. 3-61 scenario.
2. Different behaviors were observed with respect to the release of the PSST support post from the embedded stub in the two mailbox configurations. In test no. NMB-1A, which consisted of the single mailbox support impacted at a 0-degree angle, the corner bolt connecting the support post and stub failed and the support post pulled out of the stub. In test no. NMB-1B, which consisted of the dual mailbox support impacted at a 10-degree angle, the corner bolt did not fail, the support post did not release from the stub, and partial fracture of the PSST was observed. The difference in the behaviors may potentially be related to a combination of differences in the impact angle, mount configuration, and mailbox masses of the two impacts.
3. Critical impact angle (CIA) variation between the two tests may have contributed to different behaviors as noted previously. However, the testing was not conclusive as to which impact angle was more critical due to differences in mailbox and mount configurations. As such, further testing may be needed to better define the CIA for test designation no. 3-61. This would suggest that repeat testing of the same mailbox configurations with opposing impact angles could provide insight on which angle is more critical. It might also be worthwhile to consider CIA values up to the 25-degree maximum value allowed in MASH.
4. Review of the mailbox attachment to the supports in the testing suggested that both mounts were at or near the limit of mailbox retention as both mounts partially or completely released the mailboxes. This would suggest that use of heavier mailboxes with either mount may degrade performance and increase the potential for mailbox release and subsequent contact with the windshield. The ¼-in. diameter, SAE Grade 5 hardware used to attach the mailboxes to the mounts appeared to have sufficient capacity. However, other elements of the mailbox attachment proved to be weak points. The base of the mailbox failed in the single mailbox configuration and the spade bolts failed on the dual mailbox configuration.

The researchers also determined potential configurations for the four remaining dynamic component tests available in the project to meet the research objective. The following options were presented to NDOT.

1. To better determine a more accurate CIA for the PSST mailbox supports, the test nos. NMB-1A and NMB-1B mailbox configurations could be retested with the opposite 0- and 10-degree impact angles. This would provide a direct comparison of which CIA provides a more critical behavior for the mailbox supports.
2. NDOT also potentially desired testing of the TAPCO single mailbox mount. This could be conducted at one or both CIA values depending on the order of the preferred dynamic component testing.
3. The non-proprietary, single mailbox mounting bracket was only tested with mounting bolts through the base of the mailbox. If desired, dynamic component testing could be conducted on the single mailbox mounting bracket with a side flange mounted mailbox similar to the one used in test no. NBM-1B. Mailbox mass could be increased to match the 10 lb mailbox used in test no. NMB-1A.
4. Finally, 25-degree CIA values could be investigated to better bracket the range of potential mailbox support performance for the range of MASH CIA values and aid in determining appropriate CIAs for full-scale testing in Phase II of the research.

The research team presented the test results and potential options to the NDOT Technical Advisory Council (TAC) for feedback. NDOT TAC members suggested that the results of the first crash tests were sufficient for them to make internal decisions regarding the use of the mailbox mounts. As such, NDOT has elected to halt the project tasks and requested that the researchers complete the project by compiling a summary report of the effort.

9 SUMMARY AND CONCLUSIONS

A research effort was undertaken to develop a design for a MASH TL-3 compliant PSST mailbox support and evaluate the potential performance of that design through dynamic component testing. Full-scale testing of the PSST mailbox support was planned for future research if the performance of the prototype mailbox support was promising.

The research team conducted a review of previous mailbox support and PSST sign crash testing for insight into the new mailbox design. Review of NDOT mailbox support rules and available mailboxes and attachment hardware was also performed to aid in development of design criteria for the PSST mailbox support.

The design effort began with review of a preliminary PSST mailbox support design proposed by NDOT. Mailbox design criteria were established for the new design relative to the mailbox mass, the types of mounting brackets considered, the size and capacity of the mounting hardware, and the mailbox mounting height. The design was focused on PSST mailbox support for mailboxes weighing 10 lb or less that could accommodate single or dual mailboxes. A simple, non-proprietary plate mount was preferred for the single mailbox support, while both non-proprietary and commercial mounts were considered for the dual mailbox support. Design concepts for the single and dual mailbox supports were developed. A PSST mailbox support was developed that used a 2¼-in. × 12-gauge embedded stub and a 2¼-in. × 14-gauge support post. The single mailbox mount consisted of a simple bent plate with multiple mailbox mounting holes welded to a tube socket that attached to the top of the PSST support post. The dual mailbox mount design chosen was a commercial TAPCO mounting system with minor modifications for attachment to the PSST support post.

To evaluate the performance of the prototype mailbox support systems, dynamic component testing with a non-compliant 1100C vehicle under impact conditions similar to MASH test designation no. 3-61 was conducted. Testing with a non-compliant, surrogate MASH vehicle allowed the mailboxes to be more effectively evaluated than a standard sled test because the surrogate vehicle would provide more accurate impact performance and insight regarding the potential for windshield damage and occupant compartment penetration risks.

Test no. NMB-1 was performed as a dynamic component test to explore the performance of two prototype PSST mailbox supports. The test was conducted using a surrogate, non-compliant, MASH 1100C vehicle that impacted two mailbox supports in a single vehicle pass. The first mailbox support impact (single mailbox support) was identified as test no. NMB-1A, and the second mailbox support impact (dual mailbox support) was identified as test no. NMB-1B.

In test no. NMB-1A, the 2,471-lb small car impacted the single mailbox support at a speed of 63.7 mph and an angle of 0 degrees with a ¼ offset toward the left side of the vehicle. The PSST mailbox support wrapped around the front of the vehicle and released near the ground line. The mailbox was retained on the support while it was in contact with the vehicle. Vehicle damage was minimal and no contact or damage to the vehicle windshield was noted. Occupant risk measures were all within suggested MASH limits.

In test no. NMB-1B, the 2,471-lb small car impacted the dual mailbox support at a speed of 61.1 mph and an angle of 10 degrees with a ¼ offset toward the right side of the vehicle. The

PSST support post wrapped around the front of the vehicle which pulled the mailbox down toward the hood. The PSST did not separate from the embedded stub in this impact, but partial fracture of the PSST post was noted near the stub socket. The impact released the mailboxes and TAPCO mounting bracket from the PSST, and the mailbox and mounting bracket were propelled up and to the side of the 1100C vehicle with little to no relative velocity toward the windshield. No contact with the windshield or deformation or penetration of the occupant compartment were observed due to contact with the mailbox, and occupant risk measures were all within suggested MASH limits.

Following the dynamic component testing, it was noted that the performance of both PSST mailbox supports was acceptable in terms of the potential for occupant risk or occupant compartment violations. Thus, while these tests were not considered MASH compliant, the performance of the mailbox supports in these tests is potentially indicative of their performance under MASH test designation no. 3-61. Review of the test results suggested that the loading of the mailbox attachment to the PSST support was close to or exceeded the attachment capacity in both tests. As such, it was not recommended to use the PSST mailbox support with mailboxes heavier than those used in test no. NMB-1 without further investigation. It was also noted that further dynamic component testing would be worthwhile to further investigate the PSST mailbox support under other CIA values and/or using different mailbox mounting configurations. NDOT TAC members were satisfied with the performance of the PSST mailbox supports in test no. NMB-1, and no further testing was performed on the PSST mailbox support.

10 REFERENCES

1. Faller, R.K., Magdaleno, J.A., Warlick, B.A., Wendling, W.H., and Post, E.R., *Full Scale Vehicle Crash Tests on Nebraska Rural Mailbox Designs*, Final Report to Nebraska Department of Roads, RESI (0099) P415, Transportation Research Report No. TRP 03 09 87, Civil Engineering Department, University of Nebraska Lincoln, August 1987.
2. Michie, J. D., *Recommended Procedures for the Safety Performance Evaluation of Highway Appurtenances*, NCHRP Report 230, March 1981.
3. *Standard Specifications for Structural Supports for Highway Signs, Luminaires and Traffic Signals*. AASHTO, Washington, D.C., 1985.
4. *Manual for Assessing Safety Hardware (MASH), Second Edition*, American Association of State Highway and Transportation Officials (AASHTO), Washington, D.C., 2016.
5. Bligh, R.P., Menges, W.L., and Kuhn, D.L., *MASH Evaluation of TxDOT Roadside Safety Features – Phase I*, TTI Report No. Report 0-6946-1, Texas A&M Transportation Institute, January, 2018.
6. Dobrovolny, C.S., Bligh, R.P., Menges, W.L., Schroeder, G.E., and Kuhn, D.L., *MASH TL-3 Evaluation of TxDOT Extra Large Mailboxes*, TTI Report No. Report 0-6968-R9, Texas A&M Transportation Institute, October, 2020.
7. Bligh, R.P., Menges, W.L., and Kuhn, D.L., *Crash Test and Evaluation of Locking Architectural Mailboxes*, TTI Report No. Report 9-1002-12-9, Texas A&M Transportation Institute, September, 2014.
8. Bligh, R.P., Menges, W.L., Griffith, B.L., Schroeder, G.E., and Kuhn, D.L., *MASH Evaluation of TxDOT Roadside Safety Features – Phase II*, TTI Report No. Report 0-6946-R2, Texas A&M Transportation Institute, March, 2019.
9. Bullard, D.L., Bligh, R.P., Menges, W.L., and Haug, R.R., *Volume I: Evaluation of Existing Roadside Safety Hardware Using Updated Criteria—Technical Report*, NCHRP Web only Document 157, Final Report for NCHRP 22-14(03), March 2010.
10. Griffith, M.S., Federal Highway Administration (FHWA), *Eligibility Letter HSST-1/SS-180 for: MASSH-400 Sign Support*, May 21, 2019.
11. *U.S. Postal Service Standard Mailboxes, Curbside*, USPS-STD-7C, September 14, 2015.
12. Society of Automotive Engineers (SAE), *Instrumentation for Impact Test – Part 1 – Electronic Instrumentation*, SAE J211/1 MAR95, New York City, New York, July 2007.
13. Hinch, J., Yang, T.L., and Owings, R., *Guidance Systems for Vehicle Testing*, ENSCO, Inc., Springfield, Virginia, 1986.

14. MacInnis, D., Cliff, W., and Ising, K., *A Comparison of the Moment of Inertia Estimation Techniques for Vehicle Dynamics Simulation*, SAE Technical Paper Series – 970951, Society of Automotive Engineers, Inc., Warrendale, Pennsylvania, 1997.
15. *Vehicle Damage Scale for Traffic Investigators*, Second Edition, Technical Bulletin No. 1, Traffic Accident Data (TAD) Project, National Safety Council, Chicago, Illinois, 1971.
16. *Collision Deformation Classification – Recommended Practice J224 March 1980*, Handbook Volume 4, Society of Automotive Engineers (SAE), Warrendale, Pennsylvania, 1985.

11 APPENDICES

Appendix A. Commercially Available Mailbox Hardware

Potential NDOT Mailbox Options

NDOT draft rule denotes that they typically use “lightweight,” “large” standard mailboxes with dimensions in the 11” high x 14” wide x 25” maximum. Only post mounted options were collected.

NDOT Draft Rule → 003.02a Mailbox: The dimensions of the Mailbox Receptacle should be no greater than the following: width - 11 in.; height - 14 in.; and depth - 25 in. If the Mailbox Receptacle includes an integrated newspaper delivery box, the same dimensions apply except the height of the combined box should be no greater than approximately 25 in.

Note:

- Plastic mailboxes were not considered due to low weight.
- Mailboxes have both bolt through base and side mounted options. Based on TTI testing. May need both for retention. Maybe try only base mounting due to mailbox size, but that is only four ¼” or 5/16” bolts maximum for these boxes...
- Dual mount plates available with similar mounting, but bent edges.

Mailboxes

1. Salisbury Heavy Duty Rural Mailbox

- a. <https://www.mailboxes.com/heavy-duty-rural-mailbox-beige/>
- b. 7.5" W x 9.5" H x 20.5" D
- c. 15 lb – 20 lb depending on options
- d. Aluminum



- e.  All Aluminum Construction 

2. Salisbury Townhouse Mailbox - Post Style

- a. <https://www.mailboxes.com/townhouse-mailbox-post-style/>
- b. 8.5" W x 8.75" H x 21" D
- c. 25 lb
- d. Aluminum



e. All Aluminum Construction 

3. Postal Pro - Manchester Premium Mailbox

- a. <https://postalpromailboxes.com/product/the-manchester-premium-mailbox/>
- b. 22 1/2" x 9 1/2" x 10 3/4"
- c. 10 lb
- d. Heavy Duty Steel / Cast Aluminum Construction



e.

4. Postal Pro – Carlton

- a. <https://postalpromailboxes.com/product/the-carlton/>
- b. 21" D x 7 3/4" W x 9 1/2" H
- c. 9.2 lb
- d. Heavy Duty Steel Construction



e.

5. Postal Pro - Carlton Two Door Mailbox

- a. <https://postalpromailboxes.com/product/the-carlton-two-door/>
- b. 24" D x 8 1/4" W x 12" H
- c. 10 lb

d. Heavy Duty Steel Construction



e.

6. Architectural Mailboxes - Sequoia Black Heavy Duty Post Mount Mailbox

- a. <https://www.homedepot.com/p/Architectural-Mailboxes-Sequoia-Black-Heavy-Duty-Post-Mount-Mailbox-5560B-R-10/300118167>
- b. 8.1 in. W x 9.7 in. x H x 20.7 in. D
- c. Weight – 14.14 lb
- d. Steel



e.

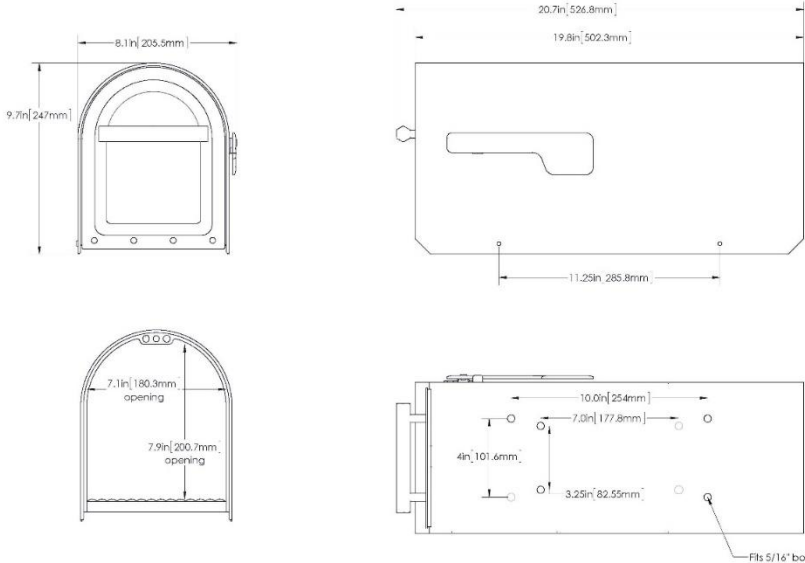

f.

7. Architectural Mailboxes Standard Metal Black Post Mount Mailbox

- a. <https://www.architecturalmailboxes.com/product/the-cambridge/>

- b. 8.9 in. W x 6.8 in. x H x 21 in. D
- c. Weight – 4.62 lb
- d. Steel



e.

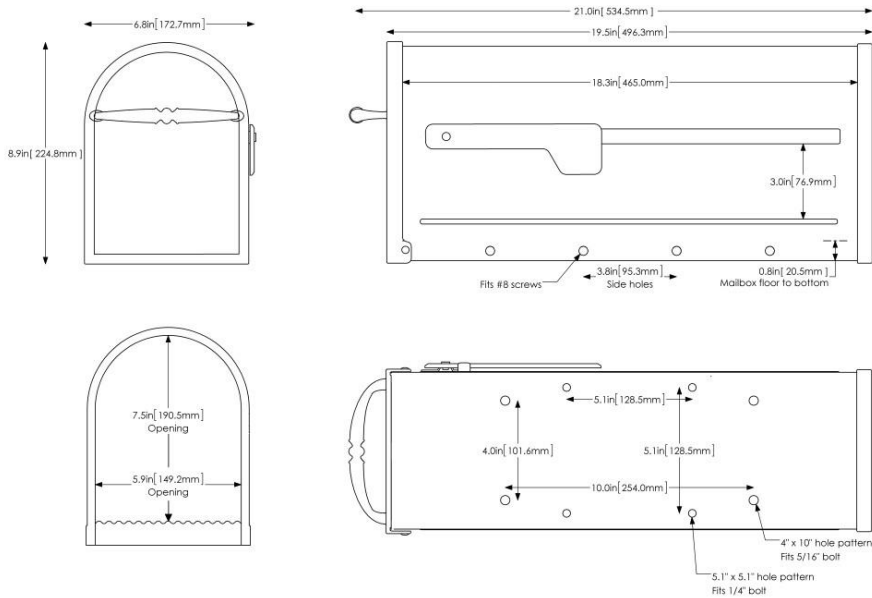

f.

- 8. Gibraltar - EDWARDS POST MOUNT MAILBOX
 - a. <https://www.gibraltarmailboxes.com/all-products/edwards-post-mount-mailbox-black/>
 - b. 10.9" H x 8.7" W x 22.4" D
 - c. 8.6 lb
 - d. Steel



- e.
9. Gibraltar - BRUNSWICK POST MOUNT MAILBOX
- a. <https://www.gibraltarmailboxes.com/all-products/brunswick-post-mount-mailbox-black-wbrushed-nickel/>
 - b. 10.8" H x 8.9" W x 23" D
 - c. 9 lb
 - d. Steel



- e.
10. Gibraltar - ARLINGTON POST MOUNT MAILBOX
- a. <https://www.gibraltarmailboxes.com/all-products/arlinton-post-mount-mailbox-bronze/>
 - b. 11" H x 9.5" W x 22.9" D
 - c. 9 lb
 - d. Steel



- e.
11. Gibraltar - ELITE LARGE POST MOUNT MAILBOX

- a. <https://www.gibraltarmailboxes.com/all-products/elite-large-post-mount-mailbox-black/>
- b. 10.9" H x 8.7" W x 22.6" D
- c. 7 lb
- d. Steel



- e.
12. Gibraltar - IRONSIDE POST MOUNT MAILBOX

- a. <https://www.gibraltarmailboxes.com/all-products/ironside-black-post-mount-mailbox-non-post-master/>
- b. 9.6" H x 7.8" W x 20.3" D
- c. 17 lb
- d. Steel



- e.
13. Gibraltar - NORTHPOINTE POST MOUNT MAILBOX

- a. <https://www.gibraltarmailboxes.com/all-products/northpointe-post-mount-mailbox/>
- b. 11.3" H x 9.3" W x 21.8" D
- c. 10.2 lb
- d. Steel



e.

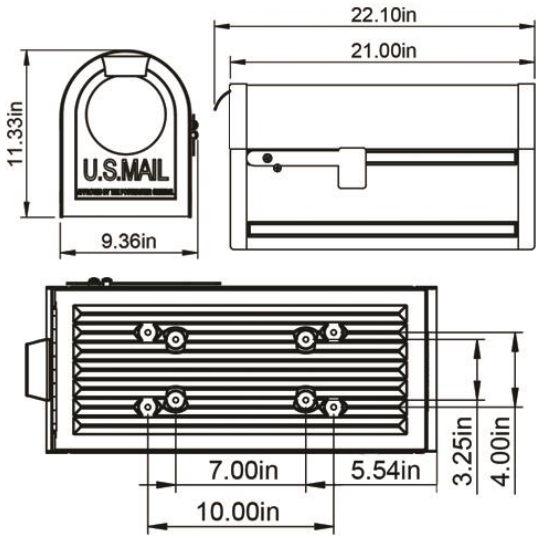

f.

14. Gibraltar - OUTBACK DOUBLE DOOR POST MOUNT MAILBOX

- a. <https://www.gibraltarmailboxes.com/all-products/outback-double-door-post-mount-mailbox-black/>
- b. 10.6" H x 8.5" W x 23.7" D
- c. 10 lb
- d. Steel



e.

15. Gibraltar - ADMIRAL LARGE POST MOUNT MAILBOX

- a. <https://www.gibraltarmailboxes.com/all-products/admiral-large-post-mount-aluminum-mailbox-black/>
- b. 11.4" H x 8.7" W 23.1" D

- c. 4.2 lb
- d. Aluminum



e.

Mounting Brackets

- 1. 4 in. x 4 in. Post Adapter in Black with 3 Mailbox Mounting Options
 - a. <https://www.homedepot.com/p/Architectural-Mailboxes-4-in-x-4-in-Post-Adapter-in-Black-with-3-Mailbox-Mounting-Options-7540B-10/206604883>



b.

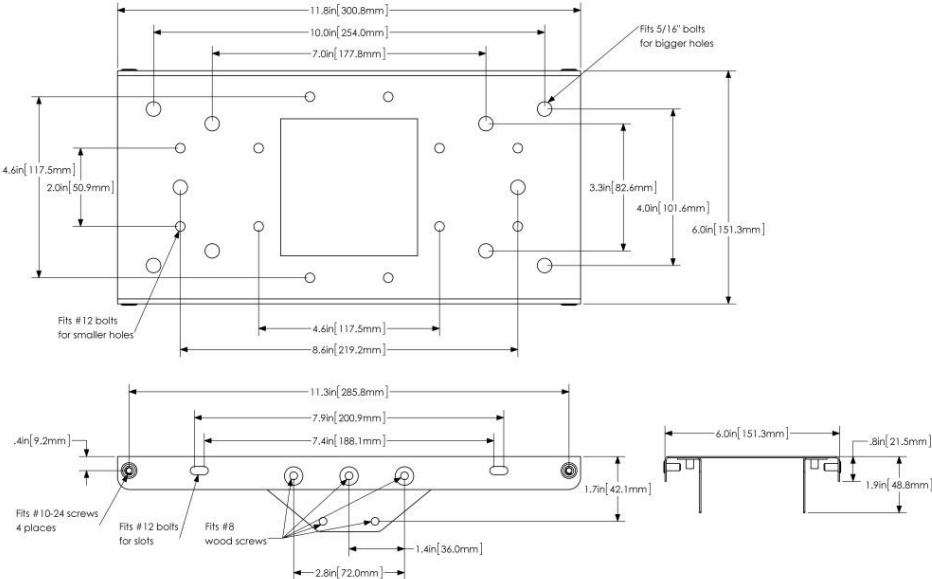

c.

2. Gibraltar Mailboxes Black Mailbox Mounting Board

- a. <https://www.lowes.com/pd/Gibraltar-Mailboxes-Steel-Mailbox-Mounting-Board/1000098418>

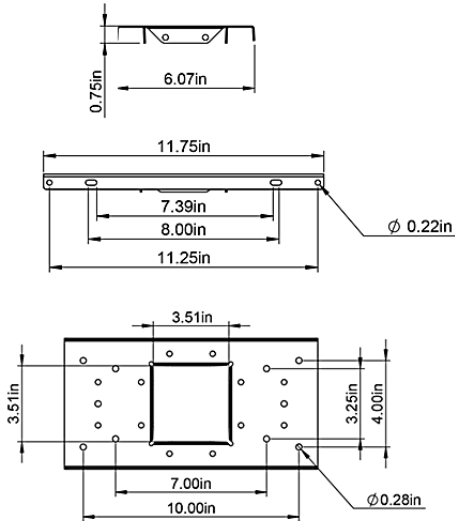

b.

3. SALSBUURY INDUSTRIES Black Mailbox Mounting Board

- a. <https://www.lowes.com/pd/SALSBUURY-INDUSTRIES-Vented-Metal-Locker-Five-Tier-Box-Style-1-Wide-5-ft-High-15-in-Deep-Gray-Unassembled/5001228907>



b.

Newspaper Holders

1. Salsbury Newspaper Holder - for Designer Roadside Mailbox

- a. <https://www.mailboxes.com/newspaper-holder-for-designer-roadside-mailbox-nickel/>
- b. 10.25" W x 5" H x 12.25" D
- c. 10 lb



- d. 
- 2. Salsbury Newspaper Holder - for Antique Rural Mailbox
 - a. <https://www.mailboxes.com/newspaper-holder-for-antique-rural-mailbox/>
 - b. 7.25" W x 4.5" H x 16" D
 - c. 10 lb



d.

Appendix B. Material Certifications

Table B-1. Bill of Materials, NMB-1

Item No.	Description	Material Specification	Reference
a1	Telespar PSST 2¼" x 2¼" x 12-gauge x 36" length	ATSM A1011 Grade 50	H#CA1613 H#A96446
a2	Telespar PSST 2" x 2" x 14-gauge x 43 ¹⁵ / ₁₆ " length	ATSM A1011 Grade 50	H#A89465
a3	2¼" x 2¼" x 14-gauge square tube	ASTM A513/ ASTN A500 Grade 50	H#126631
a4	PSST Mailbox Support Mounting Plate	ASTM A572 Grade 50	H#126631
a5	Gibraltar Northpointe Post Mount Mailbox	Galvanized Steel	Skus#2156933
b1	⁵ / ₁₆ " – 18 Corner Bolt for ¼" PSST	SAE Grade 2	H#NF13103861
b2	¼" – 20 UNC x 1" Hex Bolt	SAE Grade 2	COC P#1111005 C#220035874
b3	¼" – 20 UNC x 1" Hex Bolt	SAE J995 Grade 5	H#100105505 H#100208087
c1	⁵ / ₁₆ " – 18 Heavy Hex Jam Nut	SAE Grade 2	R#22-129
c2	¼" – 20 UNC Hex Nut	SAE Grade 2	COC, Grainger Item#2FE47 R#22-127
c3	¼" – 20 UNC Hex Nut	SAE J995 Grade 5	COC P#2136302 C#240088006
d1	¼" Diameter Plain Round Washer	SAE Grade 2	COC P#2133078 C#136865
d2	¼" Diameter Plain Round Washer	SAE Grade 5	H#1HT27 L#6B2C2FN95



ALLIED TUBE & CONDUIT PRODUCT CERTIFICATION

A01		A02 TYPE OF DOCUMENT				A03 DOC NO.								A06 CUSTOMER					
ALLIED TUBE & CONDUIT 16100 S. LATHROP AVE HARVEY, IL 60426		PRODUCT TEST REPORT AS PER ASTM A500; TEST METHOD AS PER ASTM A570				ALLIED MTR NO. 0045186								M61014 ATC/TELESPAR					
A07	CUSTOMER ORDER	PRODUCT DATE	PART NO.				DIAMETER		MIN COAT WT		GAGE		THICKNESS		B06 MARKINGS				
	N/A	5/01/20	914665 TELSQ PG/H 2.250 14 289.75SOHO				2.250				14		.083		STEEL COATING G90				
B01 PRODUCT: STEEL TUBING			B02 SPECIFICATION:						B03										
			MIN YS 60KSI						Made and Manufactured in the USA										
													TUBE MECHANICAL TEST						
B07	B16	STEEL GRADE:		A1011GR55				CHEMICAL COMPOSITION %									C11	C12	C13
		C71	C75	C74	C75	C72	C76	C82	C80	C81	C79	C78	C77	C83	CEV	YIELD STR	TENSILE STR	EL in 2"	
COIL NO.	HEAT NO.	C	Mn	P	S	Si	Al	Cu	Ni	Cr	Mo	V	Co	Ti	N	Z	KSI	KSI	%
195288	A96446	.21	.84	.009	.003	.030	.032	.110	.050	.060	.030	.003	.002	.002	.006	.378	66.1	82.9	25.5
Z01 TERMS AND CONDITIONS OF THE SALE						Z05 CERTIFICATIONS				Z04				Z02/Z03					
WE HEREBY CERTIFY THAT THE ABOVE MENTIONED MATERIAL HAS BEEN DELIVERED IN ACCORDANCE WITH THE TERMS OF THE ORDER						QS-SYSTEM:ISO 9001:2008				ALLIED TUBE & CONDUIT 16100 S. LATHROP AVE HARVEY, IL 60426 USA				METLAB Sree Harsha Lalam, Ph.D. Signature: <u>Sree Harsha Lalam</u> ALLIEDMTR-REV 00					

111

Figure B-1. Telespar PSST 2¼-in. × 2¼-in. × 12-gauge × 36-in. Length, Test No. NMB-1 (Item No. a1)



ALLIED TUBE & CONDUIT PRODUCT CERTIFICATION

A01 ALLIED TUBE & CONDUIT 16100 S. LATHROP AVE HARVEY, IL 60426		A02 TYPE OF DOCUMENT PRODUCT TEST REPORT AS PER ASTM A500; TEST METHOD AS PER ASTM A370				A03 DOC NO. ALLIED MTR NO. 0047106								A06 CUSTOMER M61014 ATC/TELESPAR					
A07 CUSTOMER ORDER	PRODUCT DATE	PART NO.				DIAMETER		MIN COAT WT		GAGE		THICKNESS		B06 MARKINGS					
N/A	5/14/21	914661 TELSQ PG/H 2.000 14 289.75SOHO				2.000				14		.083		STEEL COATING G90					
B01 PRODUCT: STEEL TUBING		B02 SPECIFICATION: MIN YS 60KSI						B03 Made and Manufactured in the USA						TUBE MECHANICAL TEST					
B07 COIL NO.	B16 HEAT NO.	STEEL GRADE:		A1011GR55				CHEMICAL COMPOSITION %									C11	C12	C13
		C71	C73	C74	C75	C72	C76	C82	C80	C81	C79	C78	C77	C83		CEV	YIELD STR	TENSILE STR	E1 in 2"
		C	Mn	P	S	Si	Al	Cu	Ni	Cr	Mo	V	Cb	Ti	N	Z	KSI	KSI	%
211415	CA1613	.22	.84	.014	.002	.030	.029	.110	.050	.060	.020	.001	.001	.001	.006	.386	61.1	77.2	27.1
Z01 TERMS AND CONDITIONS OF THE SALE WE HEREBY CERTIFY THAT THE ABOVE MENTIONED MATERIAL HAS BEEN DELIVERED IN ACCORDANCE WITH THE TERMS OF THE ORDER							Z05 CERTIFICATIONS QS-SYSTEM:ISO 9001:2008					Z04 ALLIED TUBE & CONDUIT 16100 S. LATHROP AVE HARVEY, IL 60426 USA				Z02/Z03 METLAB Sree Harsha Lalam, Ph.D. Signature: <u>Sree Harsha Lalam</u> ALLIEDMTR-REV 00			

112

Figure B-2. Telespar PSST 2-in. × 2-in. × 14-gauge × 43¹⁵/₁₆-in. Length, Test No. NMB-1 (Item No. a2)

CERTIFICATE OF CONFORMANCE

*RATNER STEEL SUPPLY
2500 WEST COUNTY ROAD B
ROSEVILLE MN 55113
1-651-631-8515

11/01/21

Page# 1

TO: ALRO GROUP
3100 EAST HIGH STREET
JACKSON, MI 49203

SHIP TO: ALRO GROUP
5859 ALRO PARK DR.
POTTERVILLE MI 48876-8795
PV08300240

SIZE: 14GA X 48.00 X 96.00
GRADE: 14 GA A1011 HSLAS-F 48 X 96
A1011 HSLAS-F G50

Bill/Ladng# 338298 B/L Date 11/01/21 Sales Ordr: 083658 01
Cust. P/O#: PV15845098-001 Part No.: 08300240

Tag# 3893005 01 Heat# 126631 MasterTag# 3315494 01
C : .051 Mn: .43 P : .014 S : .006 Al: .029 Si: .04
Ti: .002 Mo: .002 Cu: .005 V : .001 Cr: .01
Pb: .0003 Sn: .0012 Ca: .0023 N : .004 B : .0003 Ni: .004
Nb: .02
Tens: 66 Yld: 60 Elng: 30

Tag# 3893006 01 Heat# 126631 MasterTag# 3315494 01
C : .051 Mn: .43 P : .014 S : .006 Al: .029 Si: .04
Ti: .002 Mo: .002 Cu: .005 V : .001 Cr: .01
Pb: .0003 Sn: .0012 Ca: .0023 N : .004 B : .0003 Ni: .004
Nb: .02
Tens: 66 Yld: 60 Elng: 30

Tag# 3893007 01 Heat# 126631 MasterTag# 3315494 01
C : .051 Mn: .43 P : .014 S : .006 Al: .029 Si: .04
Ti: .002 Mo: .002 Cu: .005 V : .001 Cr: .01
Pb: .0003 Sn: .0012 Ca: .0023 N : .004 B : .0003 Ni: .004
Nb: .02
Tens: 66 Yld: 60 Elng: 30

Tag# 3893008 01 Heat# 126631 MasterTag# 3315494 01
C : .051 Mn: .43 P : .014 S : .006 Al: .029 Si: .04
Ti: .002 Mo: .002 Cu: .005 V : .001 Cr: .01
Pb: .0003 Sn: .0012 Ca: .0023 N : .004 B : .0003 Ni: .004
Nb: .02
Tens: 66 Yld: 60 Elng: 30

Tag# 3893009 01 Heat# 126631 MasterTag# 3315494 01
C : .051 Mn: .43 P : .014 S : .006 Al: .029 Si: .04
Ti: .002 Mo: .002 Cu: .005 V : .001 Cr: .01
Pb: .0003 Sn: .0012 Ca: .0023 N : .004 B : .0003 Ni: .004
Nb: .02
Tens: 66 Yld: 60 Elng: 30

Tag# 3893010 01 Heat# 126631 MasterTag# 3315494 01
C : .051 Mn: .43 P : .014 S : .006 Al: .029 Si: .04
Ti: .002 Mo: .002 Cu: .005 V : .001 Cr: .01

Continued...

Alro Metals/Plastics



RT 10650074

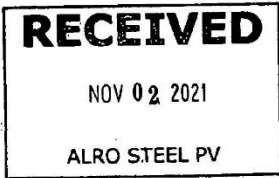

Figure B-3. PSST Mailbox Support Mounting Plate, Test No. NMB-1 (Item Nos. a3 and a4)



MENARDS - LINCOLN NORTH
3500 North 27th
Street
Lincoln, NE 68521

KEEP YOUR RECEIPT
RETURN POLICY VARIES BY PRODUCT TYPE

Unless noted below allowable returns for
items on this receipt will be in the form
of an in store credit voucher if the
return is done after 08/15/21

If you have questions regarding the
charges on your receipt, please
email us at:
LINNfrontend@menards.com



Sale Transaction

Tax Exempt Certificate ID: 2069630
Exempt Type: Public School or College

NORTHPOINTE RURAL MAILBOX
2156933 2 859.97 119.94 NT

TOTAL SALE 119.94
VISA CREDIT 1594 119.94

PG #
Auth Code:083154
Chip Inserted
a000000003101001
TC - 9777cfde88/d19ba

TOTAL NUMBER OF ITEMS = 2

THE FOLLOWING REBATE RECEIPTS WERE
PRINTED FOR THIS TRANSACTION:
680

GUEST COPY

The Cardholder acknowledges receipt of
goods/services in the total amount shown
herein and agrees to pay the card issuer
according to its current terms.

THIS IS YOUR CREDIT CARD SALES SLIP
PLEASE RETAIN FOR YOUR RECORDS.

THANK YOU, YOUR CASHIER, Etissa

18464 02 8817 05/17/21 08:29AM 3112

Figure B-4. Gibraltar Northpointe Post Mount Mailbox, Test No. NMB-1 (Item No. a5)

C B516-M-Z

PO 29353



King Steel
5225 East Cook Rd.
Grand Blanc, MI 48439

Material Certification

Heat: NF13103861
Grade: 1010
Note: .315 1010 IQ HR RD ROD

Material Specification Type	Material Specification	Actual
Chemical	Carbon (C)	.06 %
	Manganese (Mn)	.45 %
	Phosphorus (P)	.010 %
	Sulfur (S)	.031 %
	Silicon (Si)	.13 %
	Nickel (Ni)	.12 %
	Chromium (Cr)	.07 %
	Molybdenum (Mo)	.03 %
	Aluminum (Al)	.001 %
	Boron (B)	.0002 %
	Copper (Cu)	.28 %
	Vanadium (V)	.002 %
	Columbium/Niobium (Nb)	.002 %
	Tin (Sn)	.011 %
	Calcium (Ca)	.0004 %
Physical	Tensile Strength (PSI)	58252 psi
	Yield Strength (PSI)	44141 psi
	% Elongation	28 %
	Reduction Ratio:	159:1
Melted & Manufactured in:		USA

We hereby certify that chemical analysis and/or physical characteristics shown are a true copy of original test reports on file with us from the producing source covering the heat or lot from which this material was taken.

115

Figure B-5. 1/4-in.- 20 UNC x 1-in. Hex Bolt, Test No. NMB-1 (Item No. b1)



PART # 1111005
CONTROL # 220035874
DESCRIPTION 1/4"-20 x 1" Grade 2 Zinc Finish Hex Cap Screw

Re: Parts without a Material Test Report (MTR)

To whom this may concern,

Thank you for your inquiry for a Material Test Report (MTR) for the part number listed above. We are unable however to fill your request for an MTR because it is not available for this style of fastener. Fastenal will not have this on file or attempt to obtain this from our supplier(s).

Neither Fastenal nor the fastener industry will generally maintain MTR's for pins, clips, low carbon bolt/flat washers/threaded rod, socket set screws, etc. These items are manufactured from untraceable chemistry lots and are not required to meet a mechanical/performance, industry or consensus standards.

Fastenal Company maintains and provides MTRs for items mentioned in the Fastener Quality Act (FQA) such as through hardened and grade marked bolts, nuts, washers, etc. , which are required to have an MTR on record from the supplier/manufacturer and are available through www.fastenal.com/mtr. These are obtainable when searching by part and control number. For more information on whether an MTR is required, please visit our home page and click on the link for Product Standards option below the part number's product image.

FOR REFERENCE ONLY

Figure B-6. 1/4-in.– 20 UNC × 1-in. Hex Bolt, Test No. NMB-1 (Item No. b2)

NUCOR
FASTENER DIVISION

LOT NO.
4497118

Post Office Box 6100
Saint Joe, Indiana 46785
Telephone 260/337-1000

CUSTOMER NO./NAME: 7495 FASTENAL COMPANY-TX NUCOR ORDER # 257178
 TEST REPORT SERIAL# FB660936 CUST PART # 0137488
 TEST REPORT ISSUE DATE 2/05/21
 DATE SHIPPED 4/27/21 CUSTOMER P.O. # 180217501
 NAME OF LAB SAMPLER: ROBERTA COMMENT, LAB TECHNICIAN
 *****CERTIFIED MATERIAL TEST REPORT*****
 NUCOR PART NO QUANTITY LOT NO. DESCRIPTION
 4109451 2200 4497118 1/4-20 X 1 GR 5 HK CAP
 MANUFACTURE DATE 1/14/21 SCREW ZN-BLUE



--CHEMISTRY MATERIAL GRADE - 1035MR
 MATERIAL HEAT *CHEMISTRY COMPOSITION (WT% HEAT ANALYSIS) BY MATERIAL SUPPLIER
 NUMBER NUMBER C MN P S SI NUCOR STEEL - NEBRASKA
 RH034343 100105505 .36 .01 .006 .018 .24

--MECHANICAL PROPERTIES IN ACCORDANCE WITH SAE J429-14 AND ASTM A449-14

SURFACE HARDNESS (HRC)	CORE HARDNESS (RC)	PROOF LOAD 2700 LBS	TENSILE STRENGTH (LBS)	DEG-WEDGE	STRESS (PSI)
53.1	30.6	PASS	4510		140938
53.4	30.6	PASS	4610		140963
53.6	30.6	PASS	4590		143438
51.8	28.5	PASS	4680		146250
51.7	28.4				
53.3	30.6				

AVERAGE VALUES FROM TESTS
 52.8 29.9 4598 143672
 PRODUCTION LOT SIZE 219000 PCS

--SURFACE QUALITY WITHIN LIMITS PRESCRIBED IN ASTM F708/F708M-20

--COATING - .0302" min Zn (Fe/Zn 58N) per ASTM F1941-16, Clear Chromate, blue tint

1. 0.00053	2. 0.00046	3. 0.00048	4. 0.00052	5. 0.00046	6. 0.00050	7. 0.00051
8. 0.00039	9. 0.00048	10. 0.00044	11. 0.00035	12. 0.00039	13. 0.00050	14. 0.00042
15. 0.00037						

AVERAGE THICKNESS FROM 15 TESTS .00045

--HEAT TREATMENT - AUSTENITIZED, OIL QUENCHED & TEMPERED (MIN 800 DEG F)

--DIMENSIONS PER ASME B18.2.1-2012

CHARACTERISTIC	#SAMPLES TESTED	MINIMUM	MAXIMUM
Width across Corners	8	0.497	0.500
Screw Length	8	0.980	0.986
Threads	8	PASS	PASS

ALL TESTS ARE IN ACCORDANCE WITH THE LATEST REVISIONS OF THE METHODS PRESCRIBED IN THE APPLICABLE SAE AND ASTM SPECIFICATIONS. THE SAMPLES TESTED CONFORM TO THE SPECIFICATIONS AS DESCRIBED/LISTED ABOVE AND WERE MANUFACTURED FREE OF MERCURY CONTAMINATION. THE STEEL WAS MELTED AND MANUFACTURED IN THE U.S.A. AND THE PRODUCT WAS MANUFACTURED AND TESTED IN THE U.S.A. PRODUCT COMPLIES WITH CPARS 252.225-7014. WE CERTIFY THAT THIS DATA IS A TRUE REPRESENTATION OF INFORMATION PROVIDED BY THE MATERIAL SUPPLIER AND OUR TESTING LABORATORY. THIS CERTIFIED MATERIAL TEST REPORT RELATES ONLY TO THE ITEMS LISTED ON THIS DOCUMENT AND MAY NOT BE REPRODUCED EXCEPT IN FULL CERTIFICATION FORMAT MEETS EN1204 3.1



MECHANICAL FASTENER
 CERTIFICATE NO. A2LA 0139.01
 EXPIRATION DATE 12/31/21

NUCOR FASTENER
 A DIVISION OF NUCOR CORPORATION
Bob Haywood
 BOB HAYWOOD
 QUALITY ASSURANCE SUPERVISOR

Figure B-7. 1/4-in.- 20 UNC x 1-in. Hex Bolt, Test No. NMB-1 (Item No. b3)

NUCOR
FASTENER DIVISION

LDT NO.
4515929

Post Office Box 6100
Saint Joe, Indiana 46785
Telephone 260/337-1800

CUSTOMER NO/NAME
7495 FASTENAL COMPANY-TX
TEST REPORT SERIAL# FB662266
TEST REPORT ISSUE DATE 2/25/21
DATE SHIPPED 4/27/21
NAME OF LAB SAMPLER: GANN LEAVITT, LAB TECHNICIAN
NUCOR PART NO QUANTITY LDT NO. DESCRIPTION
4109451 8800 4515929 1/4-20 X 1 GR 5 HX CAP
MANUFACTURE DATE 2/14/21 SCREW ZN-BLUE

NUCOR ORDER # 257178
CUST PART # 0137488

CUSTOMER P.O. # 180217501

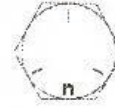

--CHEMISTRY MATERIAL GRADE -1035HR
MATERIAL HEAT **CHEMISTRY COMPOSITION (WTS) HEAT ANALYSIS) BY MATERIAL SUPPLIER
NUMBER NUMBER C MN P S SI NUCOR STEEL - NEBRASKA
RN0347L0 10020R087 .34 .78 .012 .017 .24

--MECHANICAL PROPERTIES IN ACCORDANCE WITH SAE J429-14 AND ASTM A449-14
SURFACE CORE PROOF LOAD TENSILE STRENGTH
HARDNESS HARDNESS 2700 LBS 6 DEG-WEDGE STRESS (PSI)
(R30N) (RC) (LBS) (PSI)
48.2 26.9 PASS 4500 140620
48.6 28.9 PASS 4460 139375
49.3 30.1 PASS 4460 139375
48.8 28.8 PASS 4400 137500
48.6 29.1
AVERAGE VALUES FROM TESTS
48.8 29.3 4455 139219
PRODUCTION LDT SIZE 250000 PCS

--SURFACE QUALITY WITHIN LIMITS PRESCRIBED IN ASTM F788/F788M-20

--COATING - .0002" min Zn (Fe/Zn 58N) per ASTM F1941-16, Clear Chromate, blue tint
1. 0.00034 2. 0.00022 3. 0.00027 4. 0.00024 5. 0.00021 6. 0.00026 7. 0.00024
8. 0.00027 9. 0.00024 10. 0.00029 11. 0.00035 12. 0.00025 13. 0.00027 14. 0.00034
15. 0.00027
AVERAGE THICKNESS FROM 15 TESTS .00027

--HEAT TREATMENT - AUSTENITIZED, OIL QUENCHED & TEMPERED (MIN 800 DEG F)

--DIMENSIONS PER ASME B18.2.1-2012
CHARACTERISTIC #SAMPLES TESTED MINIMUM MAXIMUM
Width Across Corners 8 0.497 0.500
Screw Length 8 0.976 0.981
Threads 8 PASS PASS

ALL TESTS ARE IN ACCORDANCE WITH THE LATEST REVISIONS OF THE METHODS PRESCRIBED IN THE APPLICABLE SAE AND ASTM SPECIFICATIONS. THE SAMPLES TESTED CONFORM TO THE SPECIFICATIONS AS DESCRIBED/LISTED ABOVE AND WERE MANUFACTURED FREE OF MERCURY CONTAMINATION. THE STEEL WAS MELTED AND MANUFACTURED IN THE U.S.A. AND THE PRODUCT WAS MANUFACTURED AND TESTED IN THE U.S.A. PRODUCT COMPLIES WITH DFARS 252-225-7014. WE CERTIFY THAT THIS DATA IS A TRUE REPRESENTATION OF INFORMATION PROVIDED BY THE MATERIAL SUPPLIER AND OUR TESTING LABORATORY. THIS CERTIFIED MATERIAL TEST REPORT RELATES ONLY TO THE ITEMS LISTED ON THIS DOCUMENT AND MAY NOT BE REPRODUCED EXCEPT IN FULL. CERTIFICATION FORMAT MEETS EN10204 3.1



MECHANICAL FASTENER
CERTIFICATE NO. AZLA 0139.01
EXPIRATION DATE 12/31/21

NUCOR FASTENER
A DIVISION OF NUCOR CORPORATION

Bob Hayward
BOB HAYWOOD
QUALITY ASSURANCE SUPERVISOR

Figure B-8. ⁵/₁₆-in.- 18 Heavy Hex Jam Nut, Test No. NMB-1 (Item No. b3)

Eberl Iron Works, Inc.
 128 Sycamore Street
 Buffalo NY 14204
 USA

Phone: (716)854-7633
 Fax: (716)854-1184

EBERL

IRON WORKS, INC.

Pack Slip: 50391

Packing Slip

Page: 1 of 1

Ship To: Shaun Tighe MIDWEST ROADSIDE SAFETY FACILITY 4630 Nw 36th St Lincoln NE 68524-1802 USA Phone: Fax: E-Mail:	Sold To: Shaun Tighe University of Nebraska 1700 Y St PO Box 880623 Lincoln NE 68588-1230 USA Phone: 402-472-9841 Fax: Billing E-Mail:
--------------------------------------------------------------------------------------------------------------------------------------------------------------------------	------------------------------------------------------------------------------------------------------------------------------------------------------------------------------------------------

Ship Date: 9/29/2021 F.O.B.:

Ship Via: 1 UPS Ground PPD/ADD Carrier: UPS

Sales Order: 49783 Your PO: NMB

PO Line	Part Number/Description Planned Qty	Rev.	Shipped Qty
1	Line 1 Rel 1 JNH516-Z / 5/16" Heavy Hex Jam Nut 10.00 EA		10.00 EA

Our Part: JNH516-Z

Packed By: _____ Pack Date: 9/29/2021 Boxes: 1 Bundles: 0 Skids/Pallets: 0

Please check materials over carefully for any shortages or damages; if found, these must be noted with the carrier on carrier's paperwork, or a claim cannot be submitted and we cannot reimburse you for, or replace, any materials. If an issue occurs with your order, please notify us within 48 hrs. No materials may be returned without prior authorization, in the form of an RMA number. Returns are at the customer's shipping expense, and are subject to inspection, upon receipt. Restocking fee may be applied. No returns will be accepted later than 30 days of customer receipt.

PackSlip-F1W

Figure B-9. 5/16-in.- 18 Heavy Hex Jam Nut, Test No. NMB-1 (Item No. c1)



Certificate of Conformance

W.W. Grainger, Inc.
100 Grainger Parkway
Lake Forest, IL. 60045-5201

September 30 2021

Attn: SHAUN M TIGHE
SHAUN M TIGHE
CANFIELD ADMINISTRATION
BLDG
LINCOLN, NE, 68588-0439

Fax #

Grainger Sales Order #: 1426756312
Customer PO #: E000910206

Dear SHAUN M TIGHE
The products sold by Grainger and that are identified in this document conform to the respective product description(s) and standard(s) as set forth on www.grainger.com.

Thank you.

Item #	Description	Vendor Part #	Catalog Page #	Order Quantity
2FE47	Hex Nut, 1/4-20, Gr 2, ZP, PK100	U08110.025.0001		1.000

Jeff Hagen | Manager, Global Operations | Supplier Contract Management | W.W. Grainger, Inc.
100 Grainger Parkway | Lake Forest, Illinois 60045

Figure B-10. 1/4-in.– 20 UNC Hex Nut, Test No. NMB-1 (Item No. c2)



Certificate of Compliance

Sold To:	Purchase Order:	E000910208
UNL / UNMC E-SHOP / PUNCHOUT	Job:	
	Invoice Date:	09/29/2021

THIS IS TO CERTIFY THAT WE HAVE SUPPLIED YOU WITH THE FOLLOWING PARTS.
THESE PARTS WERE PURCHASED TO THE FOLLOWING SPECIFICATIONS.

5 PCS 1/4"-20 x 1" Grade 5 Zinc Finish Hex Cap Screw - Made in USA SUPPLIED UNDER OUR TRACE NUMBER 180217501 AND UNDER PART NUMBER 0137488

10 PCS 1/4"-20 Zinc Finish Grade 5 Finished Hex Nut SUPPLIED UNDER OUR TRACE NUMBER 240088006 AND UNDER PART NUMBER 2136302

20 PCS 1/4" x 0.625" OD Low Carbon Zinc Finish Steel SAE General Purpose Flat Washer SUPPLIED UNDER OUR TRACE NUMBER 136865 AND UNDER PART NUMBER 2133078

10 PCS 1/4" x 0.625" OD Thru-Hardened Mechanical Galvanized Finish Steel SAE General Purpose Flat Washer SUPPLIED UNDER OUR TRACE NUMBER 120304528 AND UNDER PART NUMBER 33168

This is to certify that the above document is true and accurate to the best of my knowledge.

Please check current revision to avoid using obsolete copies.

This document was printed on 09/29/2021 and was current at that time.

Fastenal Account Representative Signature

Fastenal Store Location/Address

3201 N. 23rd Street STE 1
LINCOLN, NE 68521
Phone #: (402)476-7900
Fax #: 402/476-7958

Printed Name

Date

Figure B-11. 1/4-in.- 20 UNC Hex Nut, Test No. NMB-1 (Item No. c3)



Fastenal Company
P.O Box 1286
WINONA, MN 55987-1286

Packing Slip

Cust. No. NELIN3402
Cust. P.O. E000910208
Job No.

The store serving you is
3201 N. 23rd Street STE 1

LINCOLN, NE 68521
Phone #: (402)476-7900
Fax #: 402/476-7958

Date 9/29/21
Reference No. NELIN406901
Page 1
DUE DATE: 10/29/2021

Contract No:
2018.000208

Sold To
UNL / UNMC E-SHOP / PUNCHOUT
UNIVERSITY OF NEBRASKA
1700 Y ST
LINCOLN, NE 68588-0646

Ship To
UNL / UNMC E-SHOP / PUNCHOUT
Shaun M Tighe
4630 NW 36 ST
Shaun Tighe
LINCOLN, NE 68524

This Order and Document are subject to the "Terms of Purchase" posted on www.fastenal.com.

Line No.	Quantity Ordered	Quantity Shipped	Quantity Backorder	Description	Control No.	Part No.	Price / Hundred	Amount
1	5	5	0	HCS1/4-20x1 Z5USA	180217501	0137488	11.0300	0.55 G
2	10	10	0	1/4"-20 FHN Z 5	240088006	2136302	35.0000	3.50 G
3	20	20	0	SAE F/W 1/4 Z	136865	2133078	17.5000	3.50 G
4	10	10	0	THRU-HARD SAE 1/4 G	120304528	33168	5.9600	0.60 G

Received By

Tax Exemption
Government

Comments

Deliver To: MIDWEST ROADSIDE SAFETY FACILITY Contact: UNL

Subtotal	8.15
Shipping & Handling	0.00
State Tax	0.00
County Tax	0.00
City Tax	0.00
TOTAL USD	8.15

If you re-package or re-sell this product, you are required to maintain integrity of Country of Origin to the consumer of this product.

Reasonable collection and attorneys fees will be assessed to all accounts placed for collection
No materials accepted for return without our permission.

X indicates part is a hazardous material

* indicates part was sold at a promotional or special discount price

An electronic invoice will be available within two days.

All discrepancies must be reported within 10 days.

0

Thank You !

FORM - IN13

Figure B-12. 1/4-in. Diameter Plain Round Washer, Test No. NMB-1 (Item No. d1)

HEXICO ENTERPRISE CO., LTD.

NO.355-3,SEC. 3,CHUNG SHAN ROAD,KAU-JEN,TAINAN,TAIWAN,R.O.C.
TEL : 886 - 6 - 2390616 FAX : 886 - 6 - 2308947

MARKING

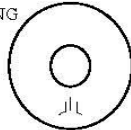

INSPECTION CERTIFICATE

CUSTOMER	<u>FASTENAL COMPANY</u>		
PART NAME	<u>FLAT WASHER</u>		
SIZE	<u>1/4 "</u>	DATE	<u>November 14, 2017</u>
PART NO. - Mfr.	<u>W2A2C2000S2JX2</u>	REPORT NO.	<u>1061114-37</u>
PART NO. - Cust.	<u>33168</u>	ORDER NO.	<u>120304528</u>
MATERIAL / DIA.	<u>10B20 / 8 mm</u>	DOCUMENT NO.	<u>10506011</u>
HEAT(COIL) NO.	<u>1HT27</u>	LOT NO.	<u>6B2C2FN95</u>
LOT QTY	<u>120,000 PCS</u>	MAF. QTY	<u>120,000 PCS</u>

THE PRODUCTS SUPPLIED ARE IN COMPLIANCE WITH REQUIREMENT OF THE ORDER.

SAMPLING PLAN STANDARD	<u>ASME B18.18-2011</u>
DIMENSION STANDARD	<u>ASME B18.21.1-2009</u>
COATING STANDARD	<u>ASTM B695-R2009</u>
HARDNESS TEST METHOD	<u>ASTM F606-2014</u>
COATING TEST METHOD	<u>ASTM E376-2011</u>
SALT PRAY TEST METHOD	<u>ASTM B117-2011</u>

DIMENSIONS IN inch

INSPECTION ITEM	SPECIFICATION	TEST QTY	INSPECTION RESULTS		INSPECTION EQUIPMENT	
			MIN.	MAX.		
1	OUTSIDE DIAMETER	0.6200 - 0.6400	8	0.6260	0.6319	Caliper
2	INSIDE DIAMETER	0.2760 - 0.2960	8	0.2850	0.2870	Caliper
3	THICKNESS	0.0510 - 0.0800	8	0.0543	0.0587	Caliper
4	HARDNESS	HRC 38 - 45	5	38.5	40.1	Rockwell
5	COATING	MECH-ZINC 53 μm	5	54.3	62.0	Magnetic
6	SALT SPRAY TEST	300 hrs. No Red Rust	5	OK		S.S.T. tester
7	APPEARANCE	VISUAL	100	OK		

INSPECTOR Yu Tain Lin

QC CHIEF Jing Yeh Tsao

Figure B-13. ¼-in. Diameter Plain Round Washer, Test No. NMB-1 (Item No. d2)

Appendix C. Vehicle Center of Gravity Determination

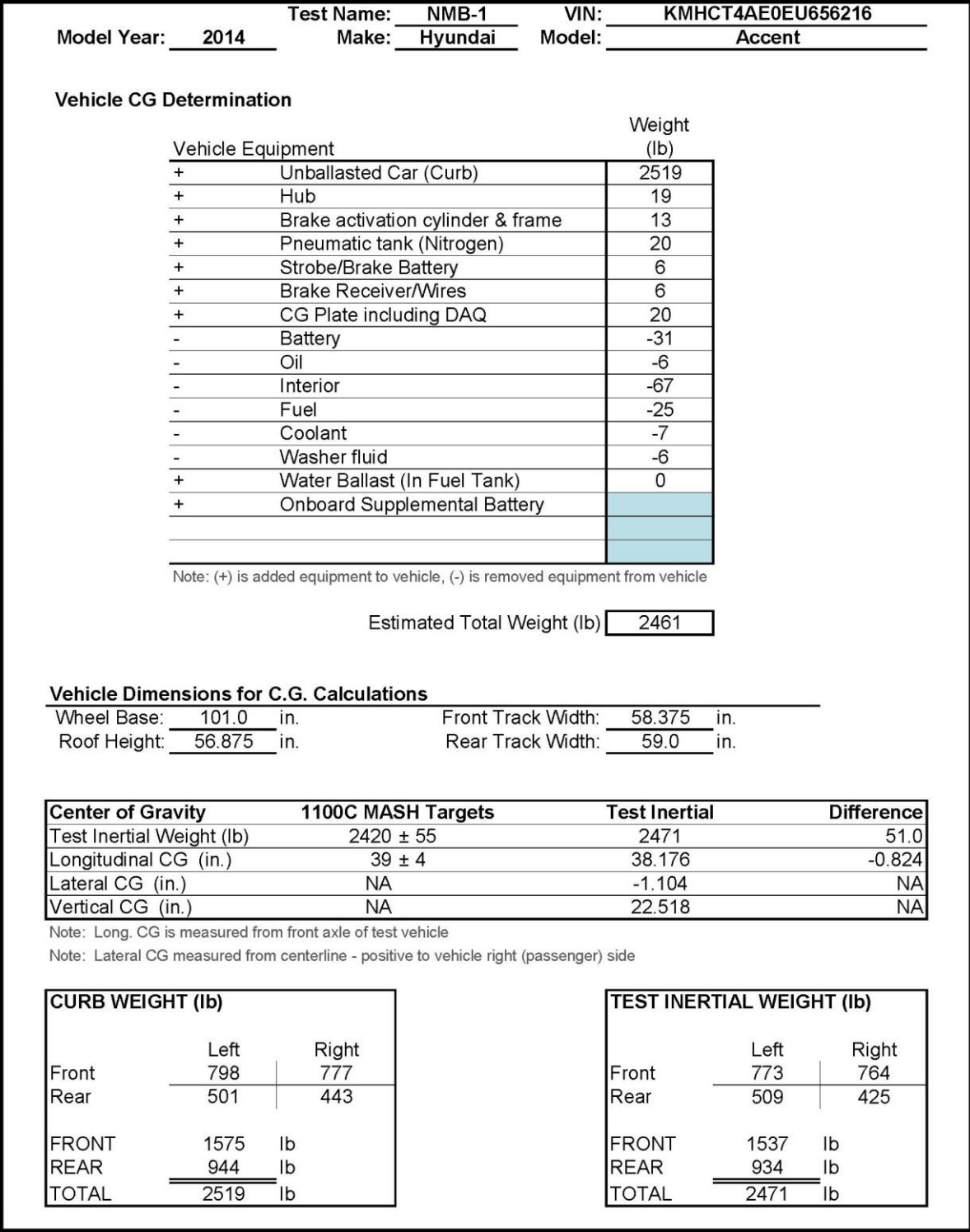

Figure C-1. Vehicle Mass Distribution, Test No. NMB-1

Model Year: <u>2014</u>	Test Name: <u>NMB-1</u>	VIN: <u>KMHCT4AE0EU656216</u>
	Make: <u>Hyundai</u>	Model: <u>Accent</u>

Vehicle CG Determination	Long CG (in.)	Lat CG (in.)	Vertical CG (in.)	Long M (lb-in.)	Lat M (lb-in.)	Vertical M (lb-in.)
+ Unballasted Car (Curb)	37.85	-0.92	22.466	95344.0	-2318.156	56590.909
+ Hub	0	-20.5	11.0	0	-389.5	209.0
+ Brake activation cylinder & frame	28.0	-12.5	13.0	364.0	-162.5	169.0
+ Pneumatic tank (Nitrogen)	66.0	13.5	11.0	1320.0	270.0	220.0
+ Strobe/Brake Battery	74.0	8.5	19.0	444.0	51.0	114.0
+ Brake Receiver/Wires	128.0	0	30.0	768.0	0	180.0
+ CG Plate including DAQ	44.0	0	17.5	880.0	0	350.0
- Battery	-8.0	-30.0	29.0	248.0	930.0	-899.0
- Oil	-9.0	0	9.0	54.0	0	-54.0
- Interior	61.0	0	13.0	-4087.0	0	-871.0
- Fuel	82.0	0	13.0	-2050.0	0	-325.0
- Coolant	-15.0	0	21.0	105.0	0	-147.0
- Washer fluid	-13.0	33.0	20.0	78.0	-198.0	-120.0
+ Water Ballast (In Fuel Tank)				0	0	0
+ Onboard Supplemental Battery				0	0	0
				0	0	0
				0	0	0
Note: (+) is added equipment to vehicle, (-) is removed equipment from vehicle				93468.0	-1817.156	55416.909

Estimated CG Location (in.)	37.98	-0.738	22.518
-----------------------------	-------	--------	--------

Calibrated Scales Used			
Equipment Type	Manufacturer	Serial #	Capacity
Pad Scale	Pennsylvania Scale	95-228908	5000 lb
Pad Scale	Pennsylvania Scale	95-228909	5000 lb
Race Wheel Scales	Intercomp	22033056	1500 lb/pad

Notes:

Figure C-2. Vehicle Mass Distribution, Test No. NMB-1

Appendix D. Accelerometer and Rate Transducer Data Plots, Test No. NMB-1

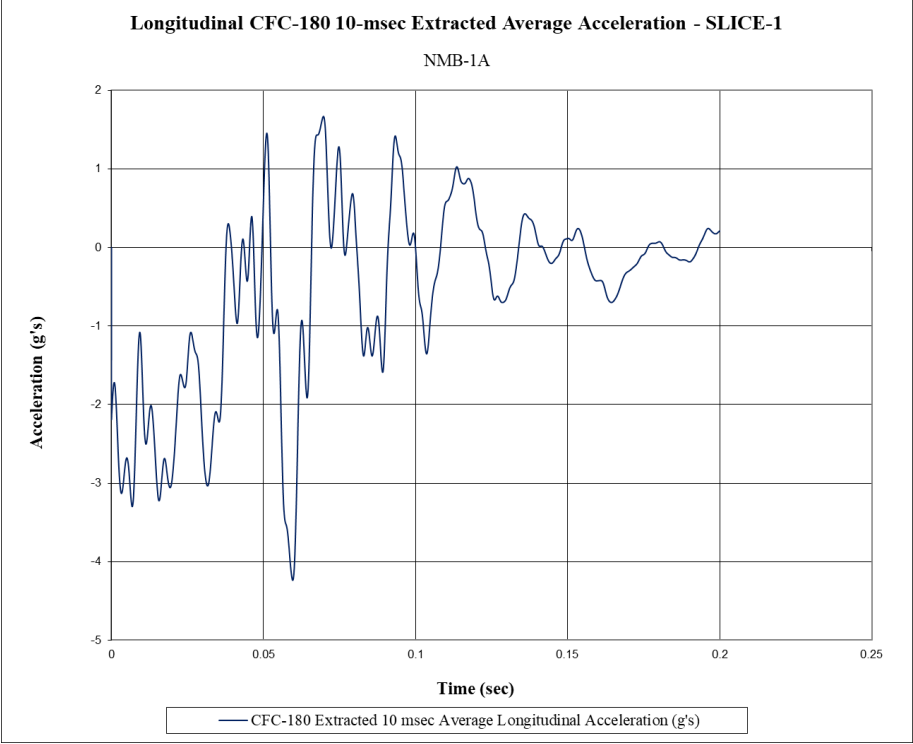

Figure D-1. 10-ms Average Longitudinal Deceleration (SLICE-1), Test No. NMB-1A

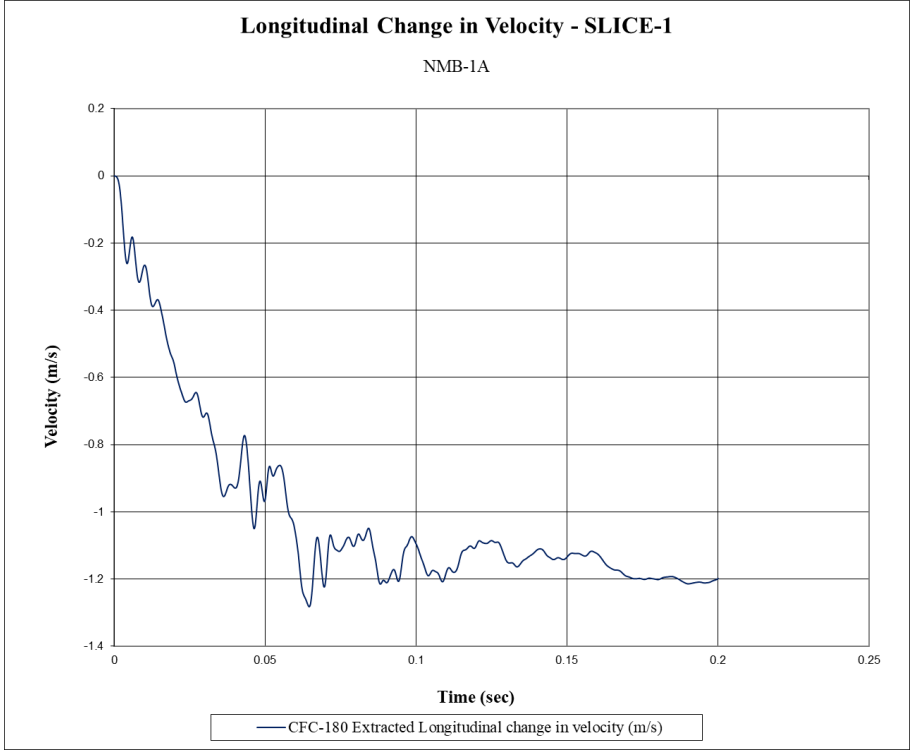

Figure D-2. Longitudinal Occupant Impact Velocity (SLICE-1), Test No. NMB-1A

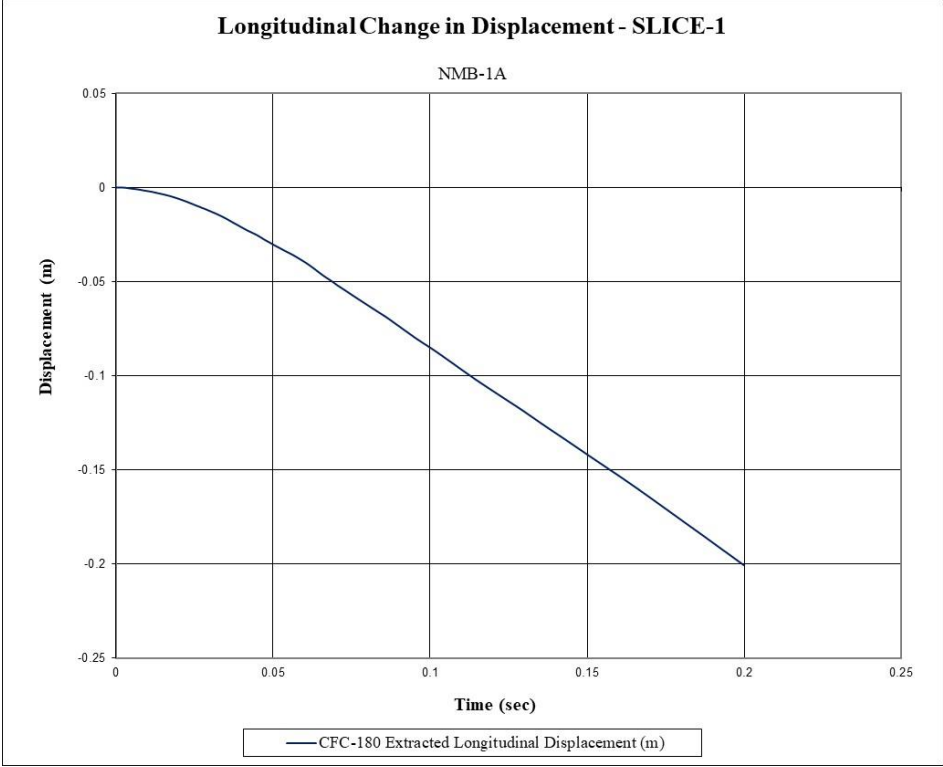

Figure D-3. Longitudinal Occupant Displacement (SLICE-1), Test No. NMB-1A

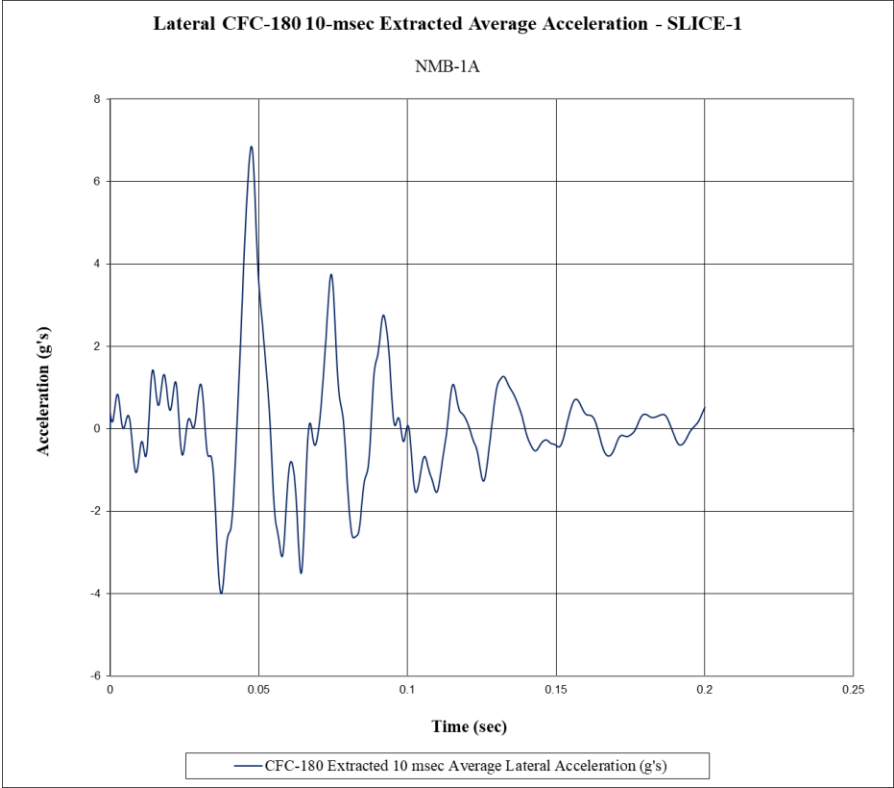

Figure D-4. 10-ms Average Lateral Deceleration (SLICE-1), Test No. NMB-1A

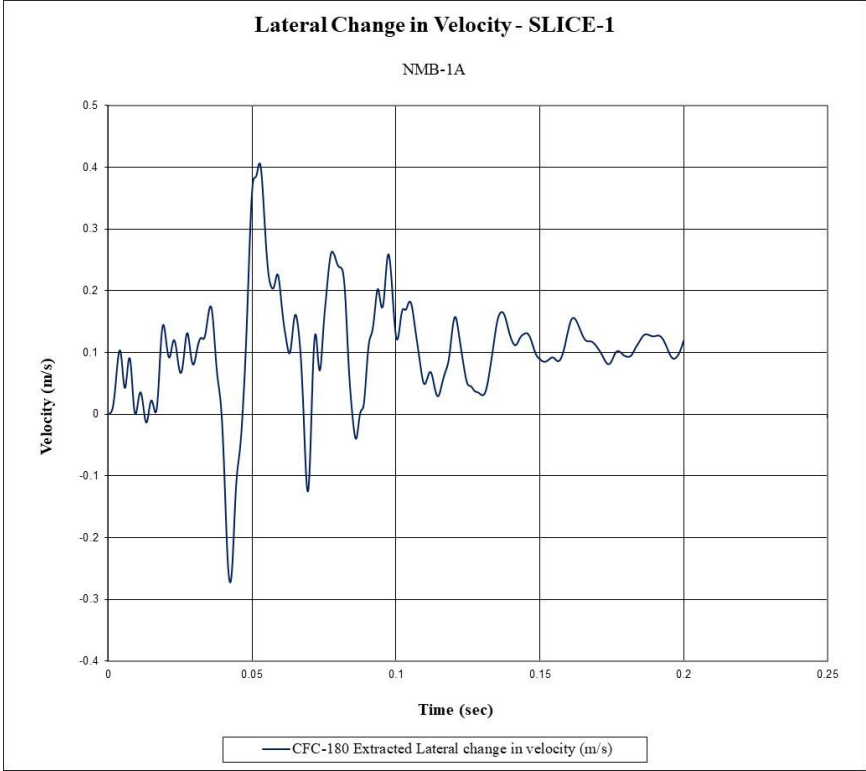

Figure D-5. Lateral Occupant Impact Velocity (SLICE-1), Test No. NMB-1A

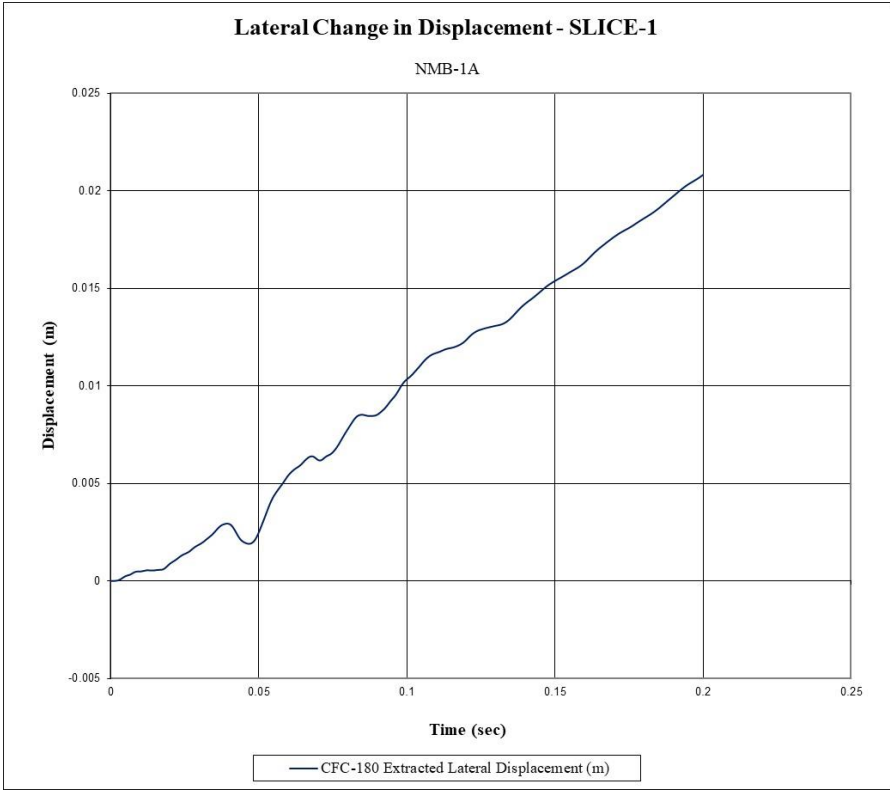

Figure D-6. Lateral Occupant Displacement (SLICE-1), Test No. NMB-1A



Figure D-7. Vehicle Angular Displacements (SLICE-1), Test No. NMB-1 A

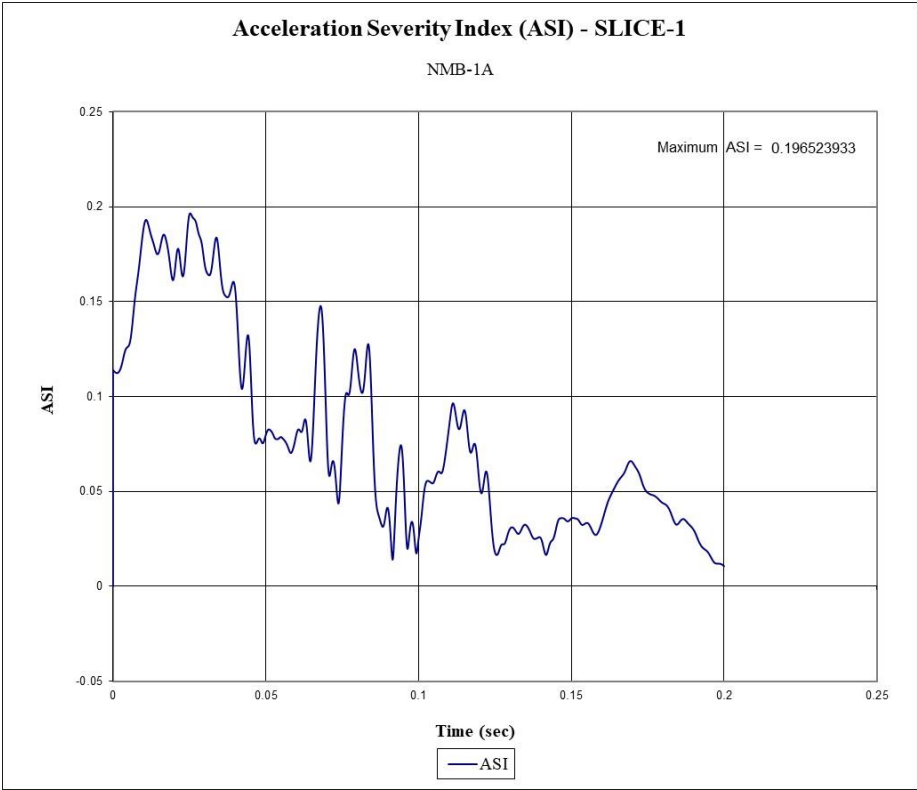

Figure D-8. Acceleration Severity Index (SLICE-1), Test No. NMB-1A

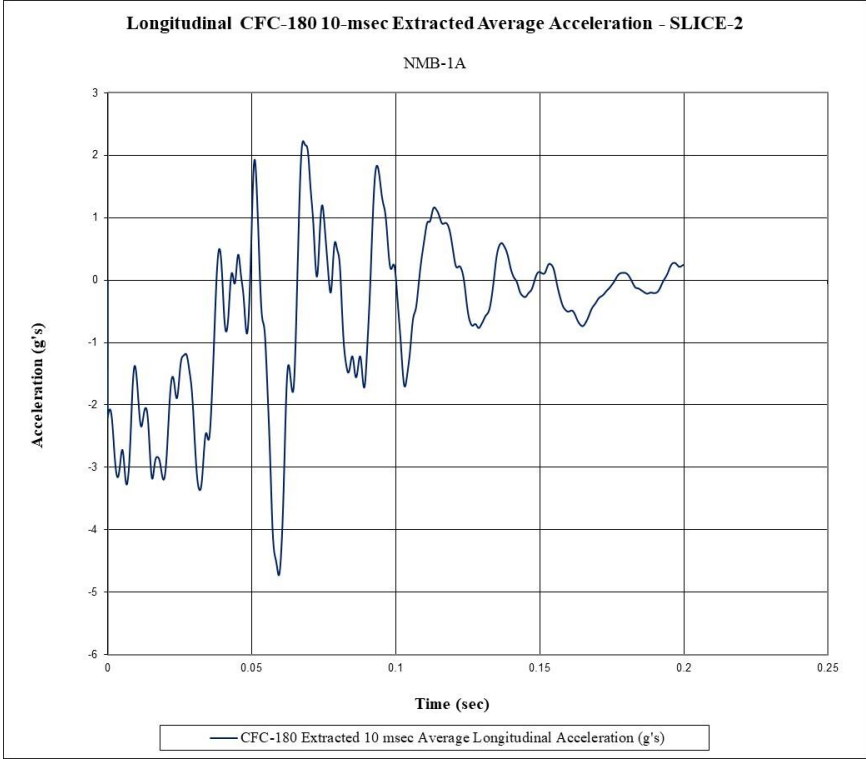

Figure D-9. 10-ms Average Longitudinal Deceleration (SLICE-2), Test No. NMB-1A

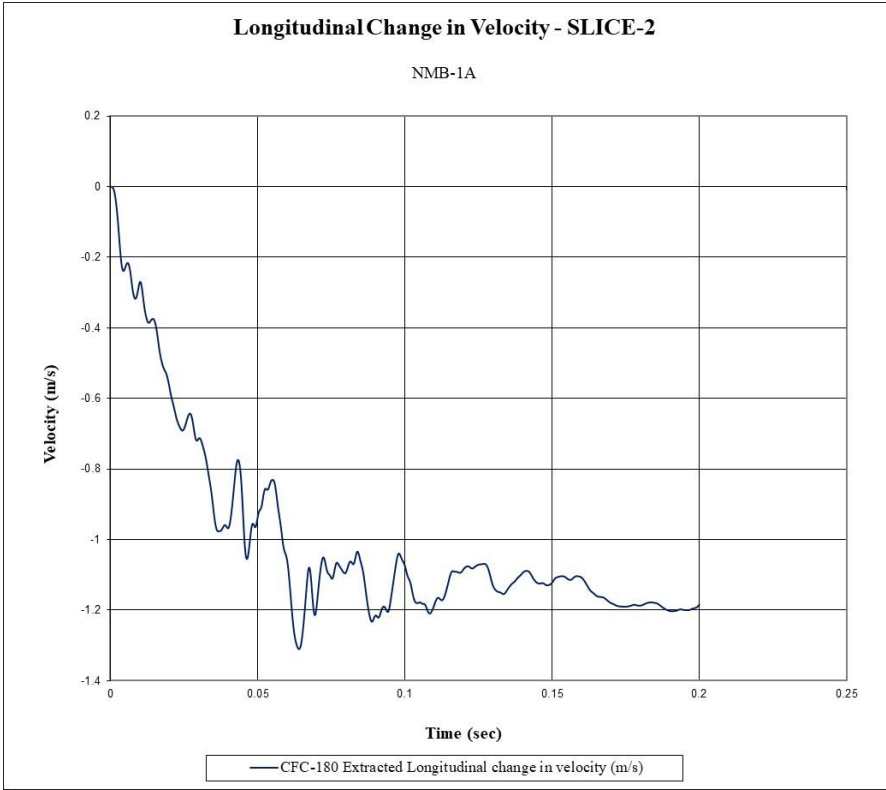

Figure D-10. Longitudinal Occupant Impact Velocity (SLICE-2), Test No. NMB-1A

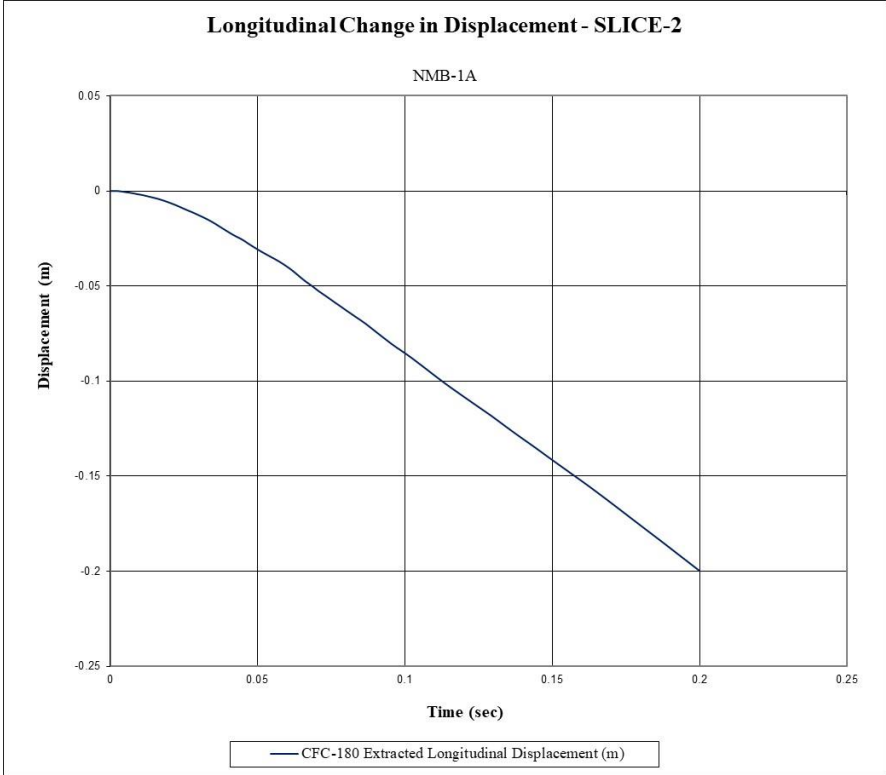

Figure D-11. Longitudinal Occupant Displacement (SLICE-2), Test No. NMB-1A

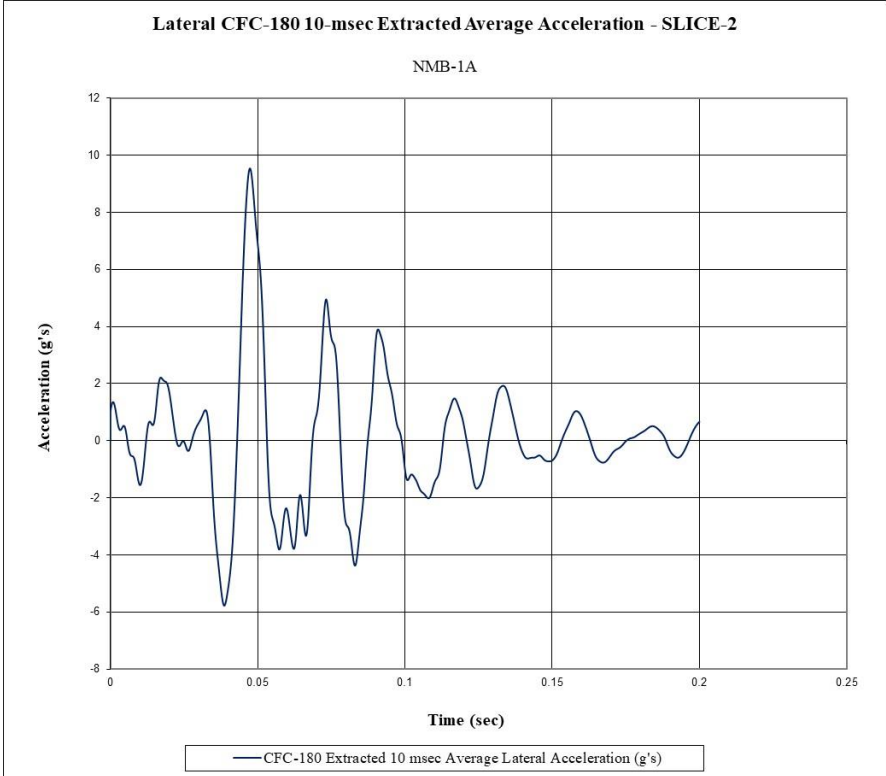

Figure D-12. 10-ms Average Lateral Deceleration (SLICE-2), Test No. NMB-1A

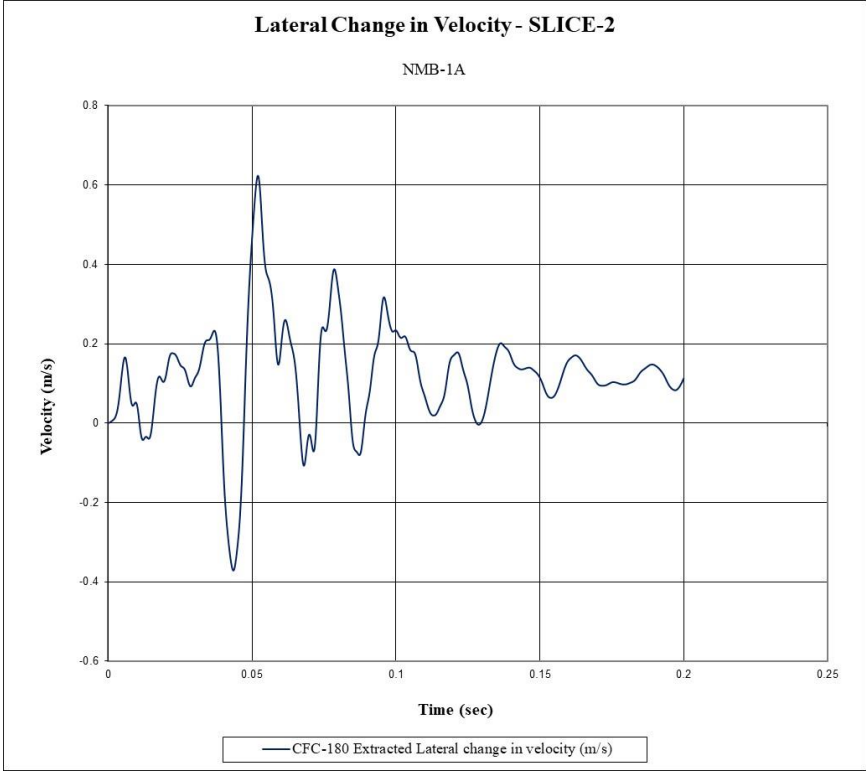

Figure D-13. Lateral Occupant Impact Velocity (SLICE-2), Test No. NMB-1A

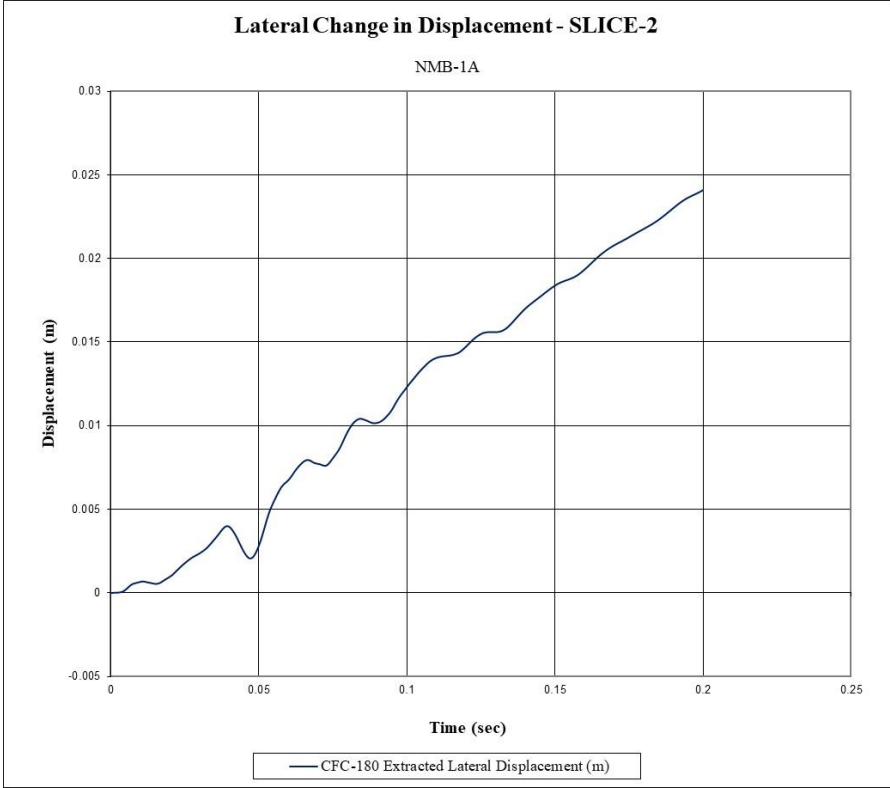

Figure D-14. Lateral Occupant Displacement (SLICE-2), Test No. NMB-1A

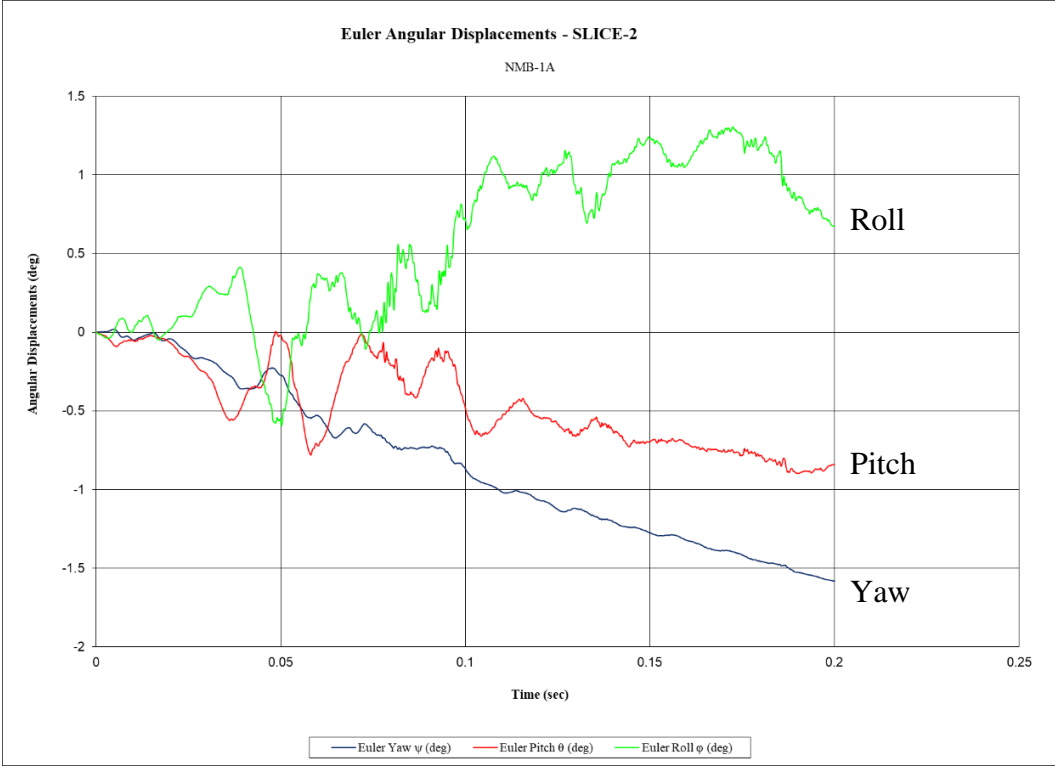

Figure D-15. Vehicle Angular Displacements (SLICE-2), Test No. NMB-1A

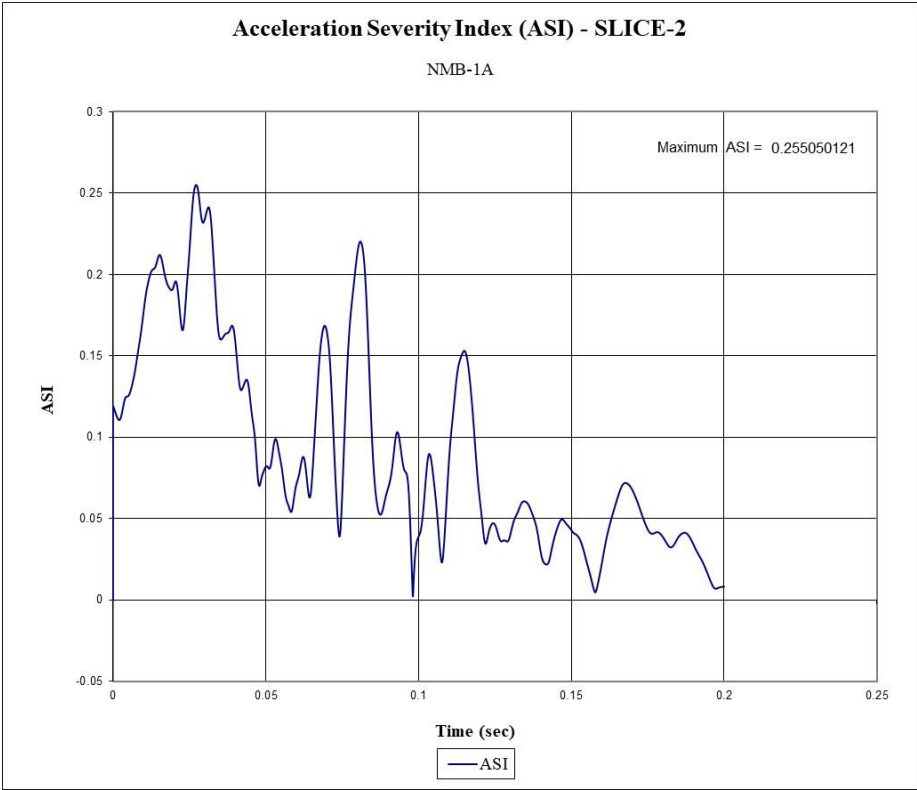

Figure D-16. Acceleration Severity Index (SLICE-2), Test No. NMB-1A

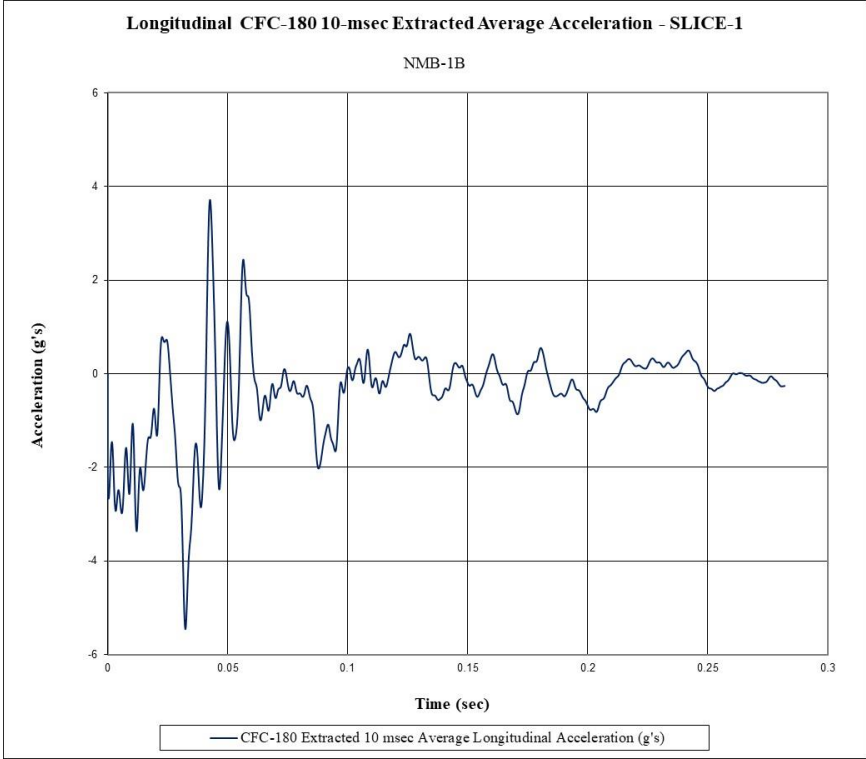

Figure D-17. 10-ms Average Longitudinal Acceleration (SLICE-1), Test No. NMB-1B

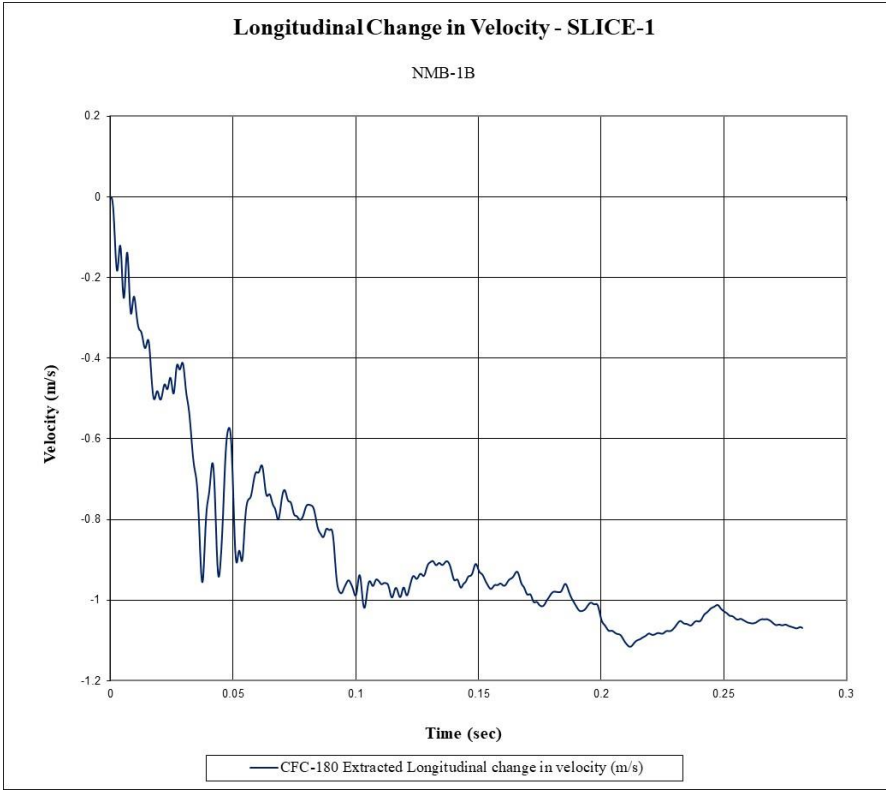

Figure D-18. Longitudinal Occupant Impact Velocity (SLICE-1), Test No. NMB-1B

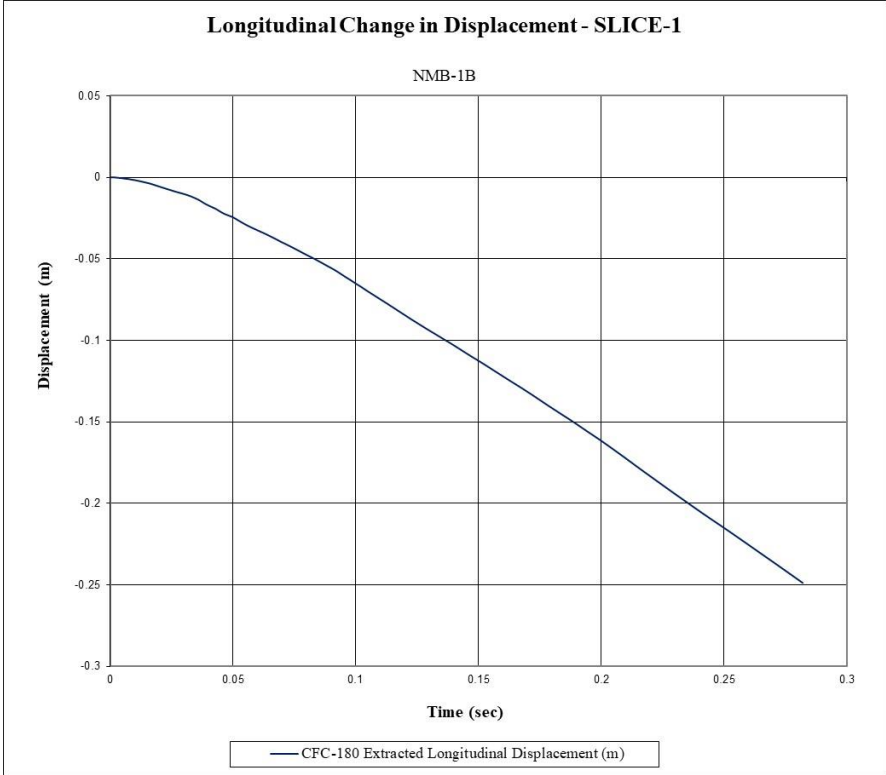

Figure D-19. Longitudinal Occupant Displacement (SLICE-1), Test No. NMB-1B

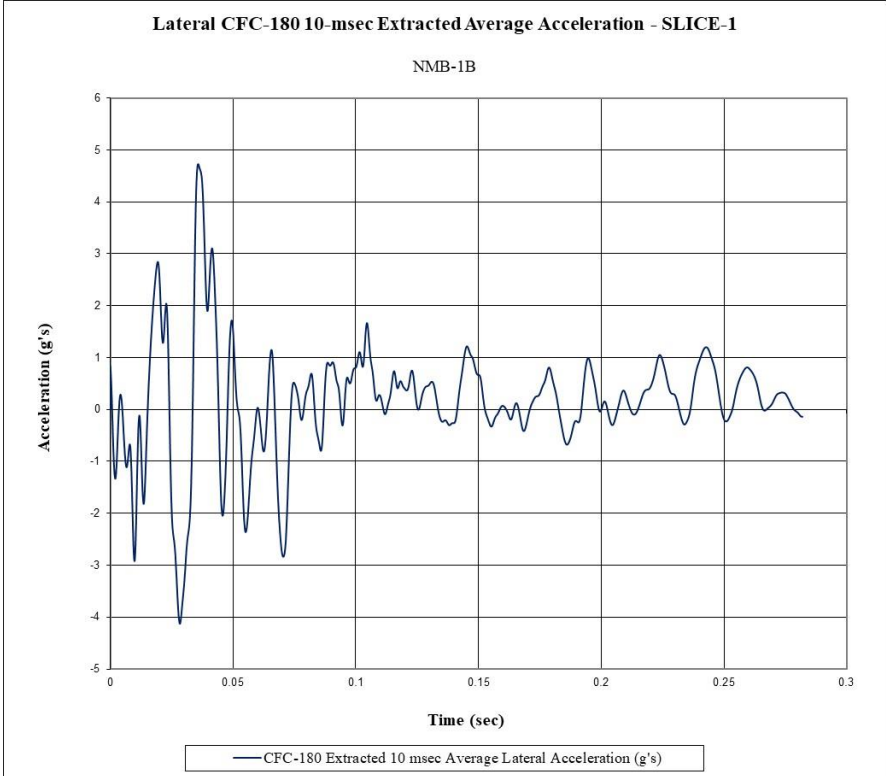

Figure D-20. 10-ms Average Lateral Deceleration (SLICE-1), Test No. NMB-1B

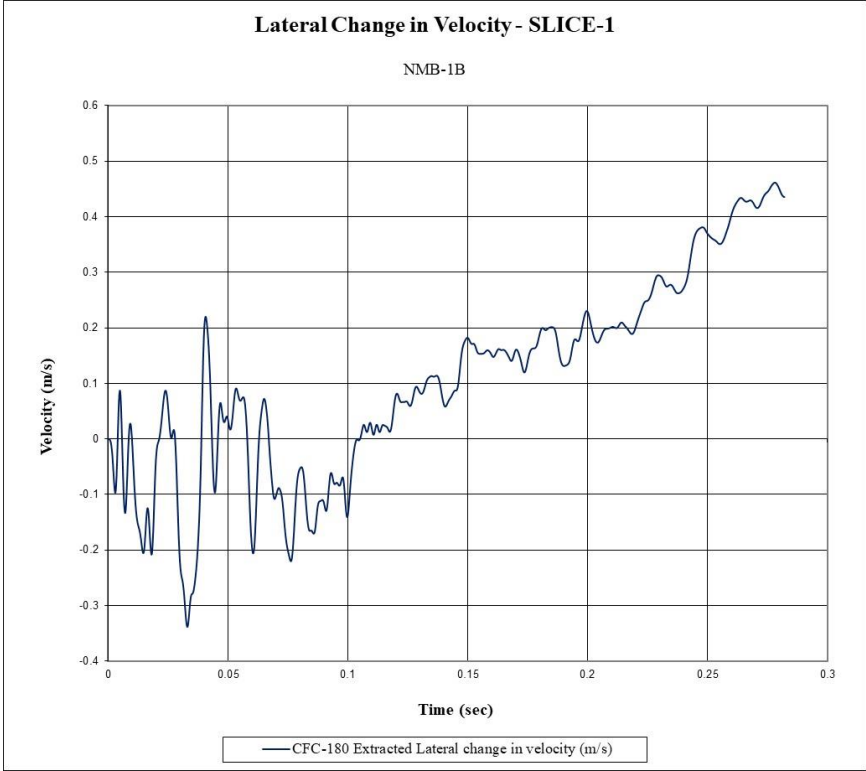

Figure D-21. Lateral Occupant Impact Velocity (SLICE-1), Test No. NMB-1B

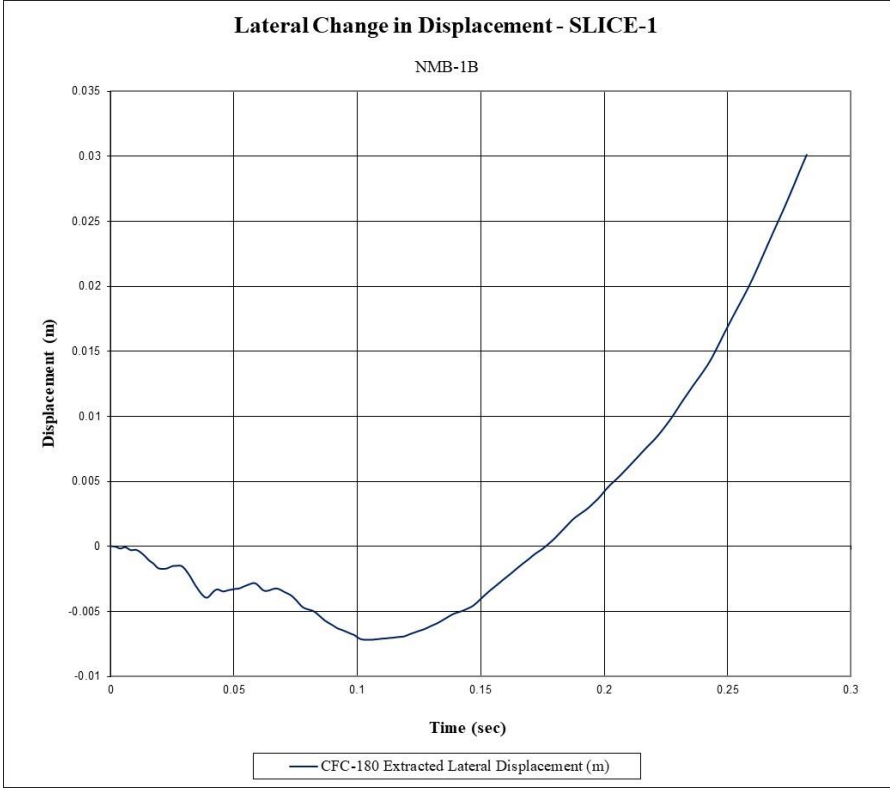

Figure D-22. Lateral Occupant Displacement (SLICE-1), Test No. NMB-1B

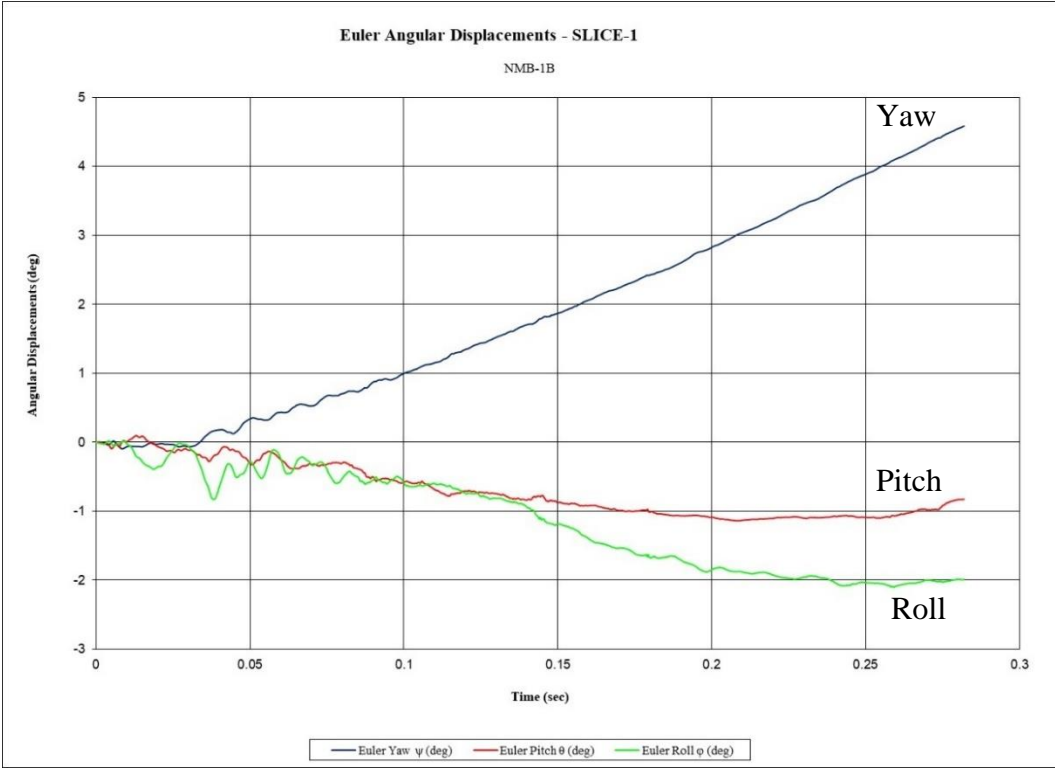

Figure D-23. Vehicle Angular Displacements (SLICE-1), Test No. NMB-1B

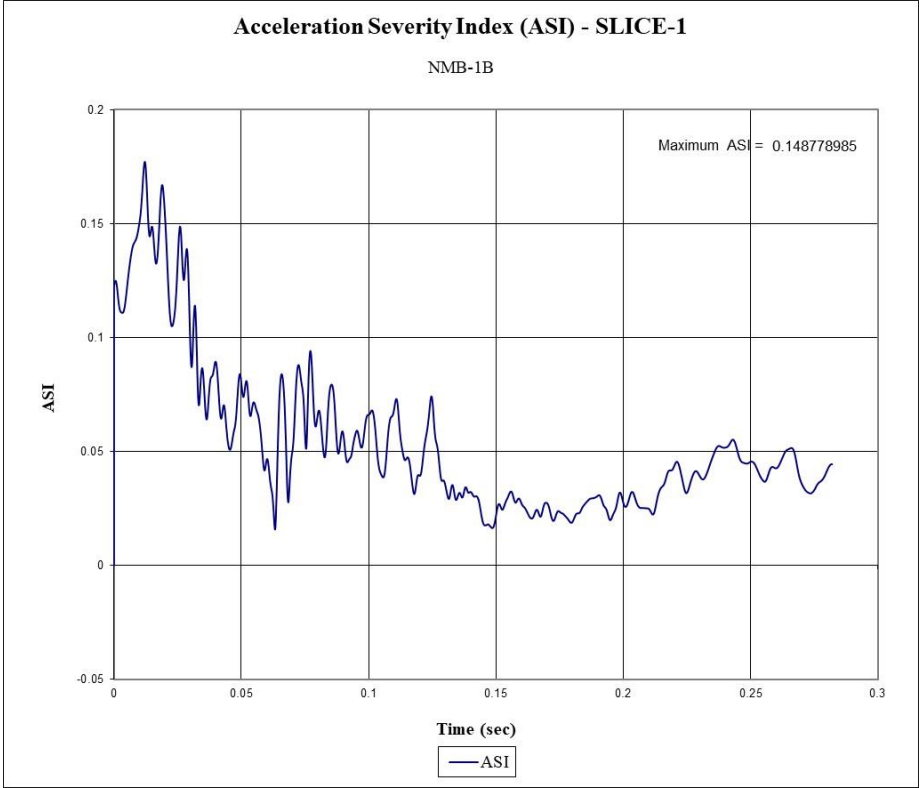

Figure D-24. Acceleration Severity Index (SLICE-1), Test No. NMB-1B

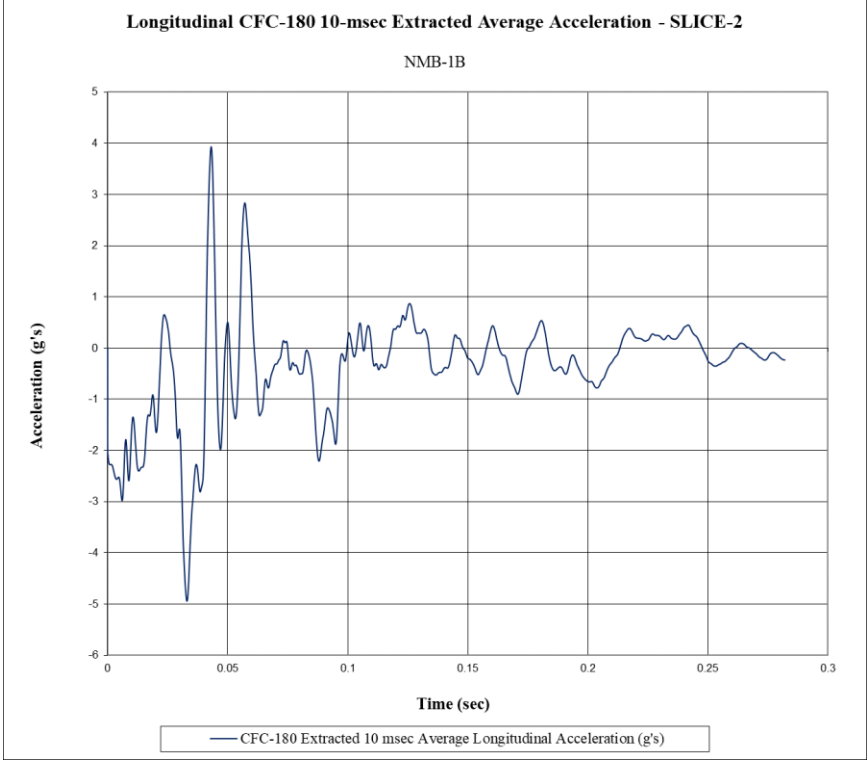

Figure D-25. 10-ms Average Longitudinal Deceleration (SLICE-2), Test No. NMB-1B

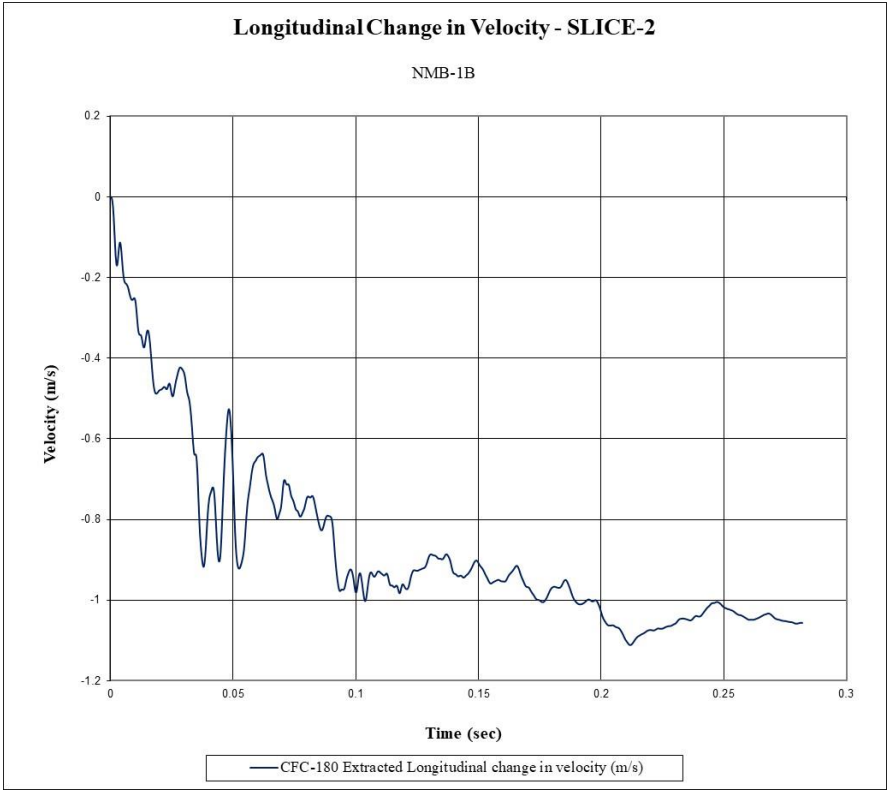

Figure D-26. Longitudinal Occupant Impact Velocity (SLICE-2), Test No. NMB-1B

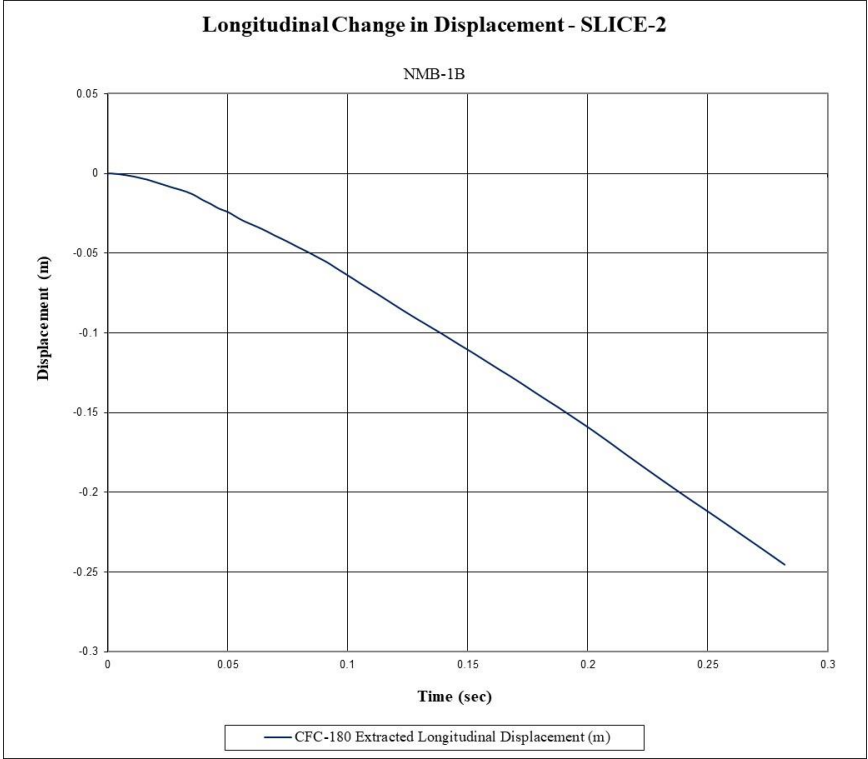

Figure D-27. Longitudinal Occupant Displacement (SLICE-2), Test No. NMB-1B

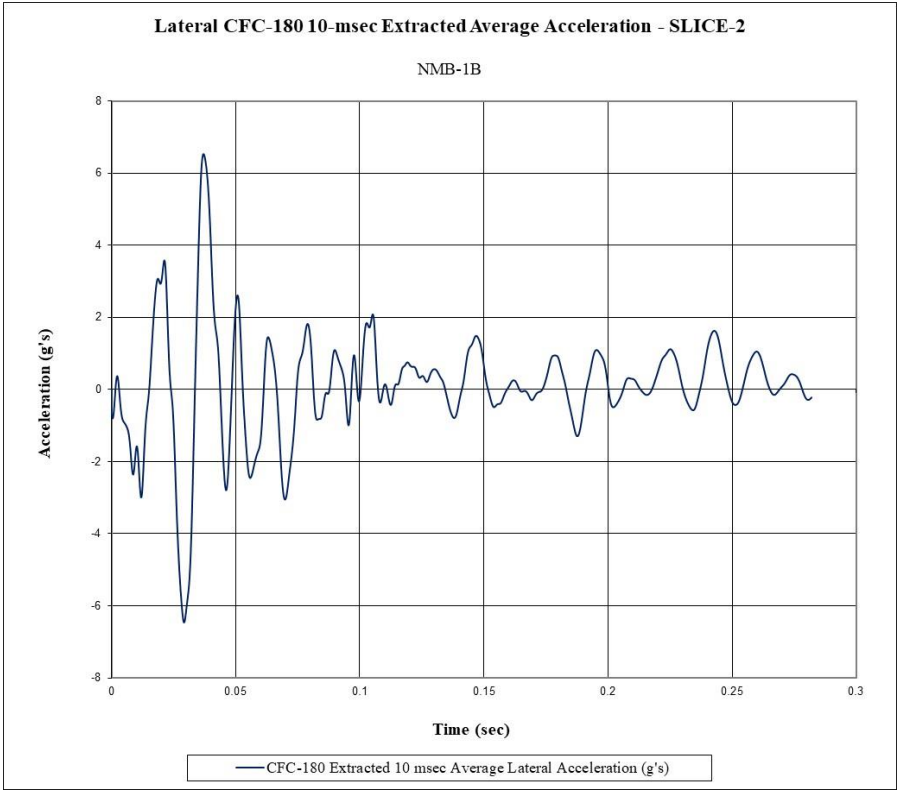

Figure D-28. 10-ms Average Lateral Deceleration (SLICE-2), Test No. NMB-1B

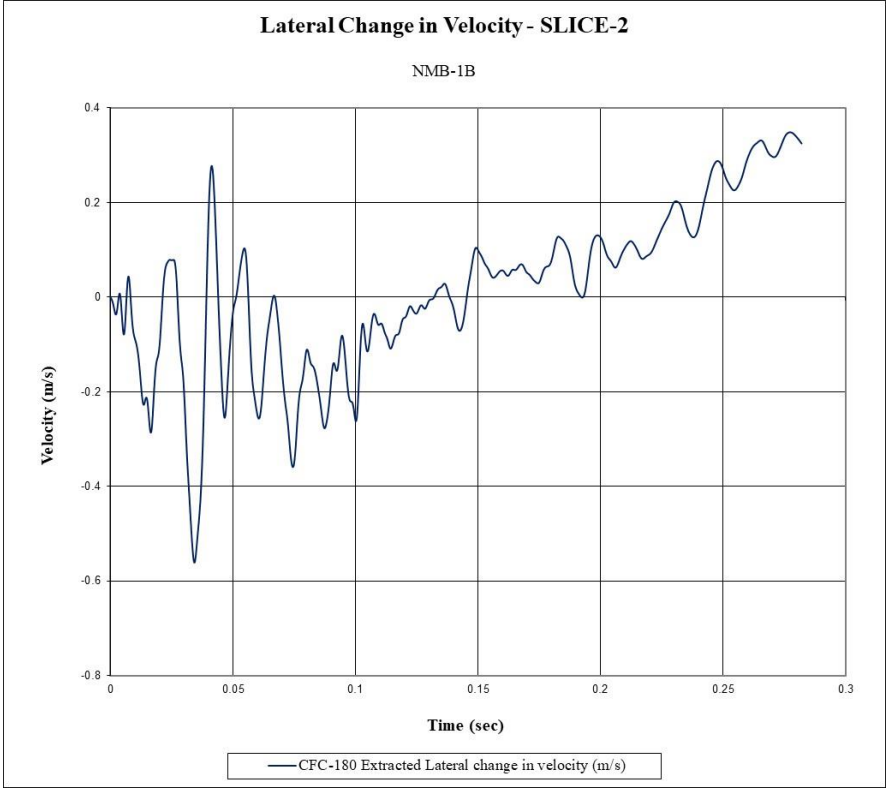

Figure D-29. Lateral Occupant Impact Velocity (SLICE-2), Test No. NMB-1B

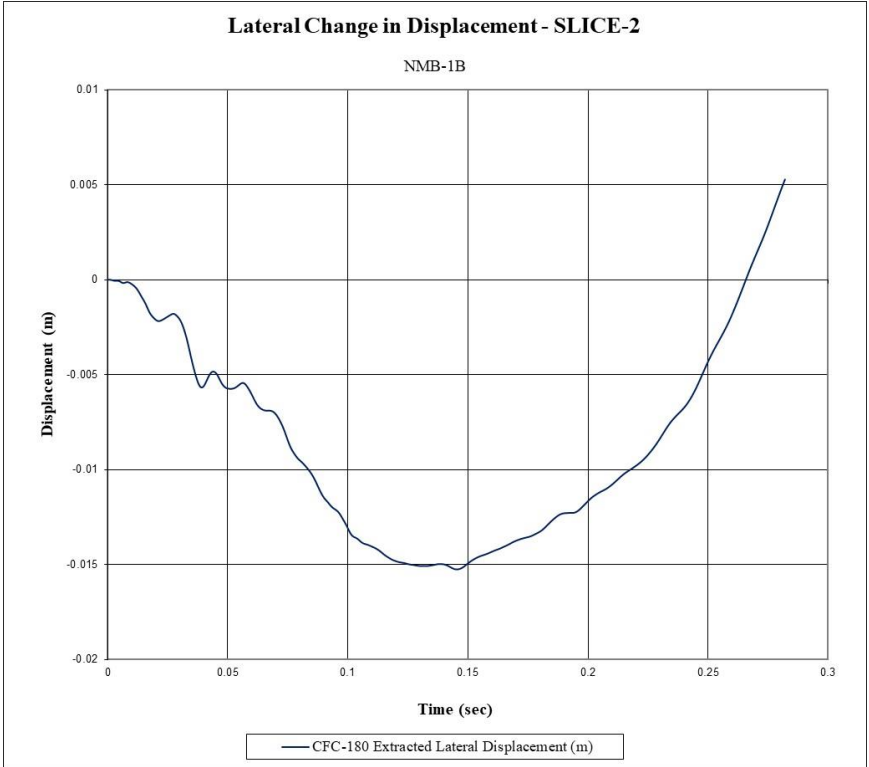

Figure D-30. Lateral Occupant Displacement (SLICE-2), Test No. NMB-1B

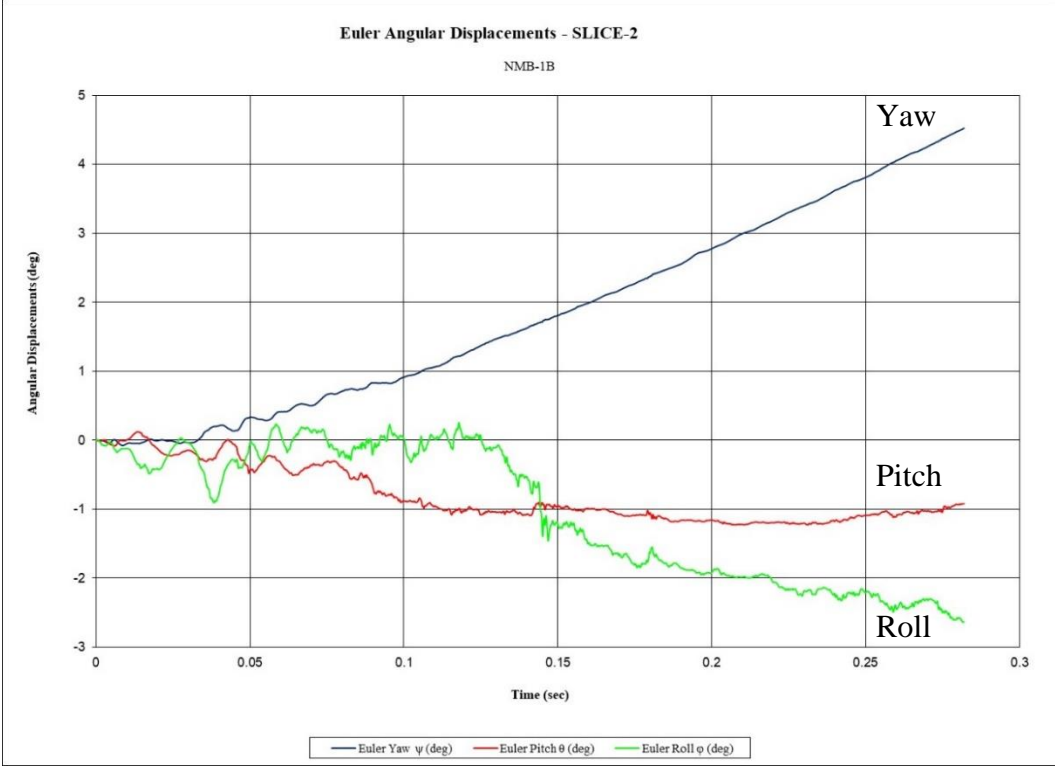

Figure D-31. Vehicle Angular Displacements (SLICE-2), Test No. NMB-1B

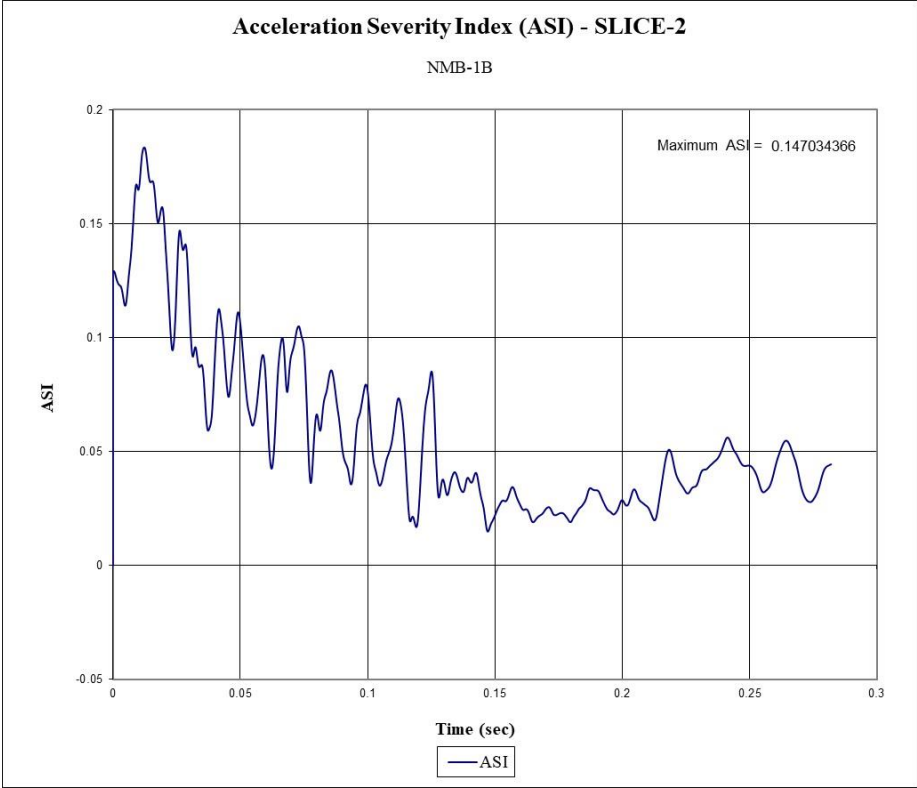

Figure D-32. Acceleration Severity Index (SLICE-2), Test No. NMB-1B

END OF DOCUMENT