



Design Problem #2 Transition From PCB to Permanent Concrete Barrier

Dean L. Sicking

2004 Roadside Safety Workshop

June 23-24, 2004



Problem

- Portable Concrete Barrier (PCB) connection to rigid structures
 - Concrete bridge rails
 - Bridge piers
- PCB's have significant deflection
- High potential for snag at the connection between the PCB and rigid hazard

Problem



Problem



Disclaimer

- No current proven solutions to this problem
- The following is our best estimate based on available research and engineering judgment
- Further research is underway

Limited Deflection PCB Options

- Concrete surface
 - Strap tie-down for F-shape PCB's
 - Bolt through tie-down for F-shape PCB's
- Asphalt Surface
 - Asphalt pin tie-down in development at MwRSF

Strap Tie-Down



Bolt Through Tie-Down



Asphalt Pin Tie-Down Concept

- Three pins per barrier on the front face
- Testing mid-summer 2004
- May be a future option

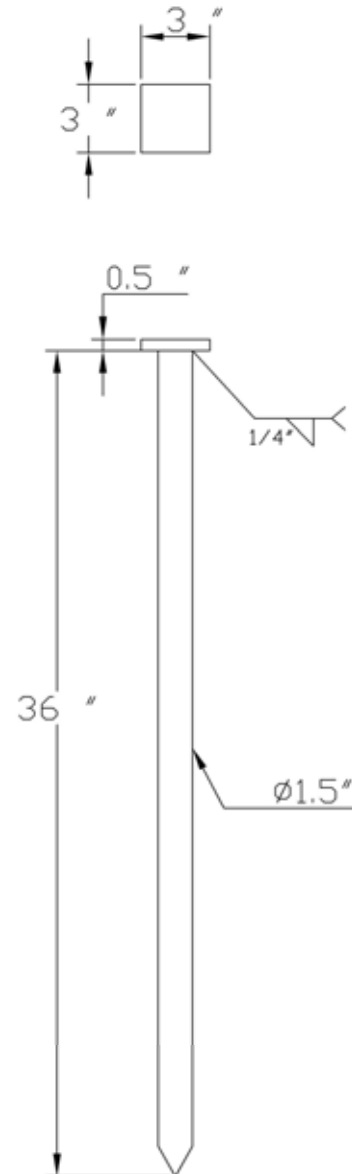

NOTE:

A36 1.5" PIN

A36 3X3X0.5' PLATE

Current Recommendation

- Tangent three barrier transition region using the bolt through tie-down
 - 1st barrier upstream of rigid hazard has bolts in all three holes
 - 2nd barrier upstream of rigid hazard has bolts in the two outside holes
 - 3rd barrier upstream of rigid hazard has bolt in the downstream hole only

Current Recommendation

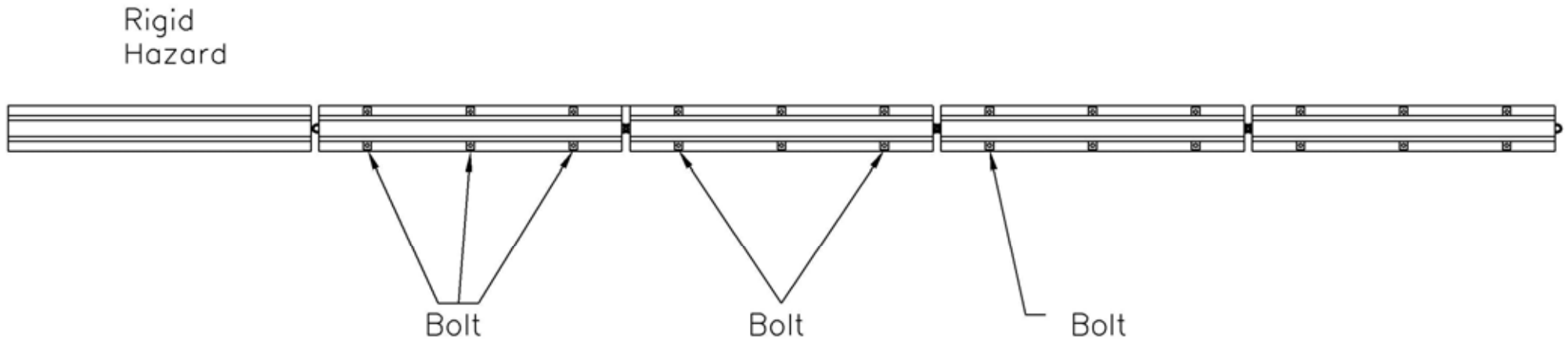

Potential Issues

- Snagging at rigid hazard due to translation and rotation of PCB
- Pocketing of PCB's due to short length of the transition
- Excessive barrier damage to partially pinned/ bolted barriers
- For use on concrete only

Improved Solution

- In order to reduce the potential problems, an improved concept has been developed
 - Lengthen the transition region using an additional barrier with three bolts
 - Apply 10 gauge thrie beam guardrail with end shoes across the final PCB and the rigid hazard to reduce snag potential

Improved Solution

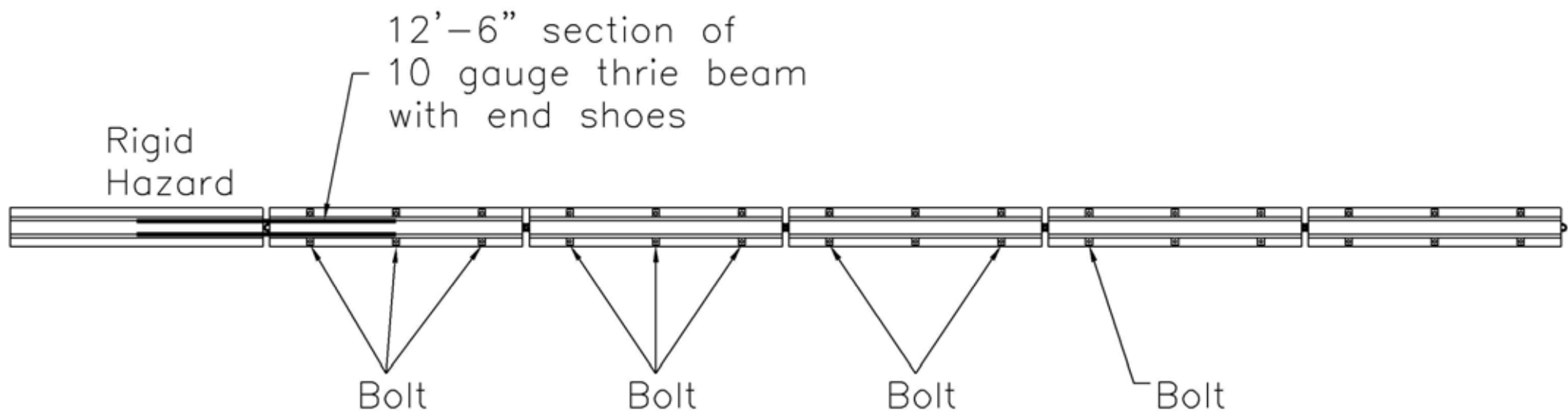

Disclaimer

- Previous slides represent the best judgment available at this time
- Not suitable for use on asphalt road surfaces
- Recommendations for asphalt surfaces will become available after testing this summer
- Further analysis will be done as part of funded research in the next 12 – 24 months