

PLAN

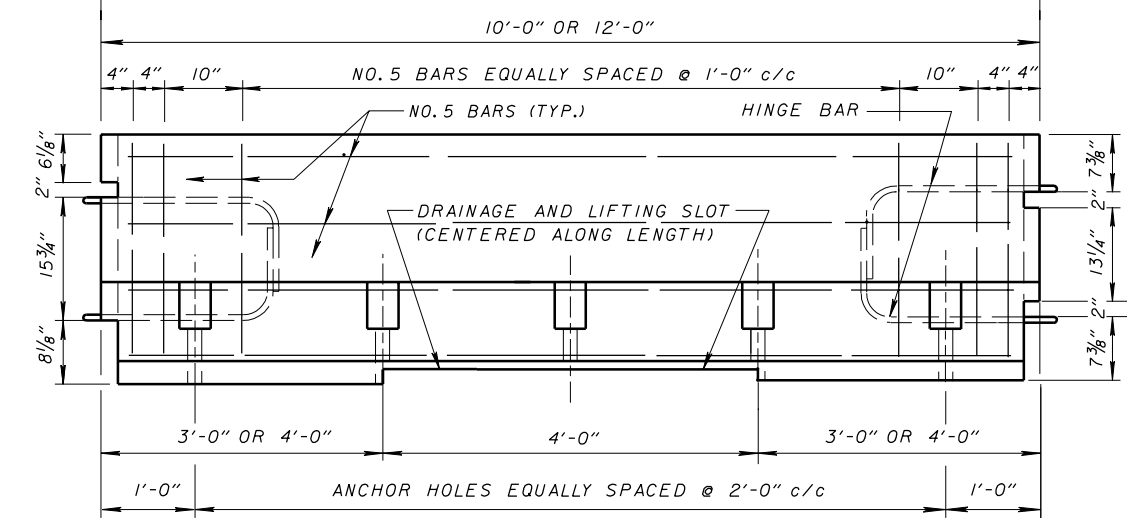

ELEVATION

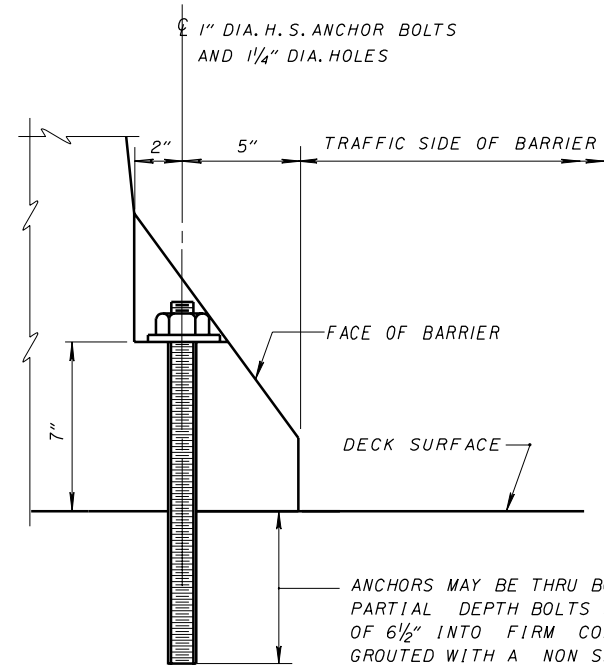

DETAIL C

- 1 1" RADIUS OR 3/4" CHAMFER ALL TOP AND END CORNERS
- 2 PERMISSIBLE 10" RADIUS
- 3 PERMISSIBLE 1" RADIUS

ANCHORS MAY BE THRU BOLTS OR PARTIAL DEPTH BOLTS. PARTIAL DEPTH BOLTS SHALL BE EMBEDDED A MINIMUM OF 6 1/2" INTO FIRM CONCRETE ACCORDING TO 510 AND GROUTED WITH A NON SHRINK, NON METALLIC GROUT CONFORMING TO 705.20. WHEN NO LONGER NEEDED, REMOVE ANCHORS AS DIRECTED BY THE ENGINEER. WHERE DECK IS TO REMAIN, FILL HOLES WITH GROUT, 705.20.

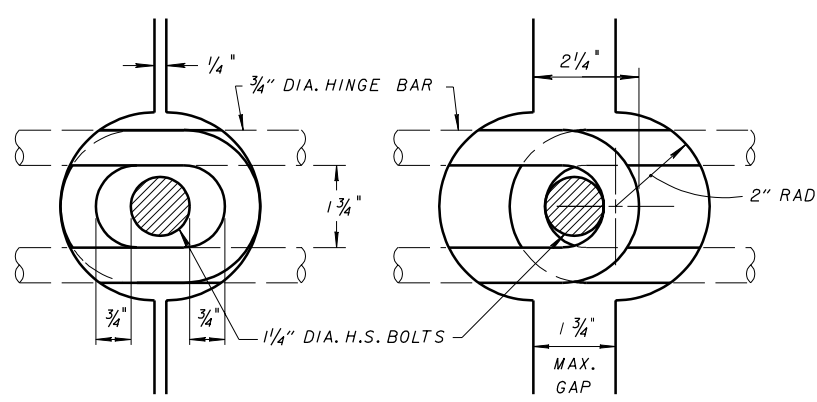

1 CLOSED JOINT 2 OPEN JOINT

JOINT CONNECTION DETAILS

- 1 BARRIERS SHALL INITIALLY BE PLACED CLOSER TOGETHER SO BOLTS CAN BE EASILY INSERT-THROUGH HINGE BAR LOOPS.
- 2 BARRIER JOINTS SHALL BE FULLY OPEN BEFORE NUT IS TIGHTENED ONTO BOLT

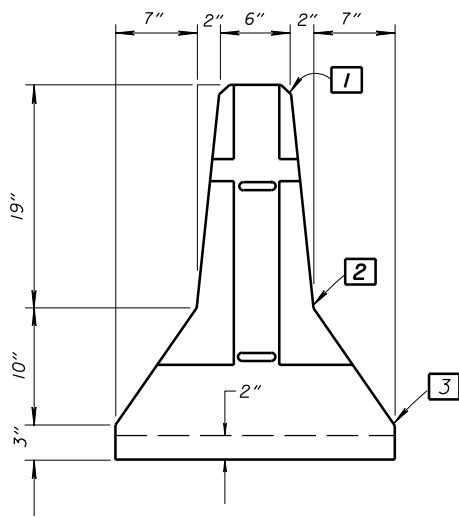

VIEW A-A

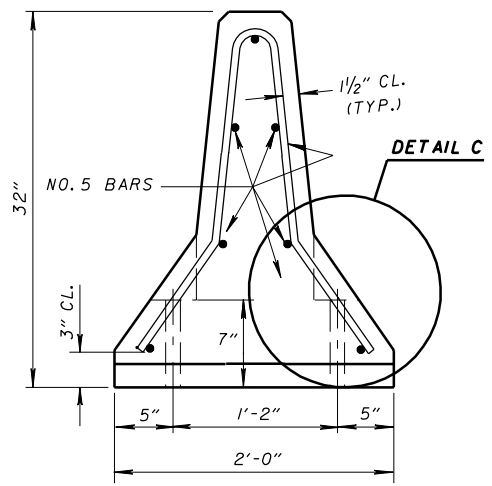

SECTION B-B

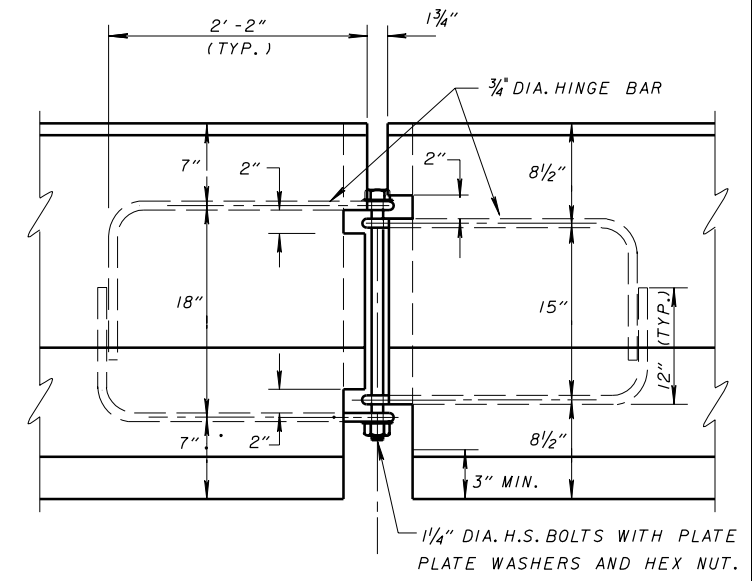

DETAIL AT HINGED CONNECTION

GENERAL NOTES

DESCRIPTION: THE BRIDGE MOUNTED PORTABLE CONCRETE BARRIER IS COMPLIANT WITH NCHRP REPORT 350. UNANCHORED, THE BARRIER HAS BEEN SUCCESSFULLY CRASH TESTED TO THE TEST LEVEL 3 CRITERIA. FULLY ANCHORED ON THE TRAFFIC SIDE, THE BARRIER SATISFIES THE TEST LEVEL 4 CRITERIA.

HARDWARE: ALL BOLTS, ANCHORS, NUTS AND WASHERS SHALL CONFORM TO 711.09 (ASTM A325) AND SHALL BE GALVANIZED ACCORDING TO 711.02.

REINFORCING STEEL: FURNISH ALL REINFORCING STEEL, INCLUDING THE 3/4" DIA. HINGE BARS, ACCORDING TO 509.02. GALVANIZE THE HINGE BARS ACCORDING TO 711.02 AFTER FABRICATION.

CONCRETE: FURNISH CLASS C CONCRETE WITH A MINIMUM COMPRESSIVE STRENGTH OF 4,000 PSI.

BRIDGE DECK SURFACE PREPARATION: THE CONCRETE SURFACE, WHERE THE BARRIER IS TO BE PLACED, SHALL BE FREE OF LOOSE SAND, GRAVEL, DIRT OR OTHER FOREIGN MATERIAL. LEVEL ALL SURFACE IRREGULARITIES TO THE SATISFACTION OF THE ENGINEER WITH GROUT OR ASPHALT. PLACE ROLLED ASPHALT ROOFING MATERIAL ON THE SURFACE AREAS THAT, AT THE DISCRETION OF THE ENGINEER, HAVE INSUFFICIENT ROUGHNESS TO PROVIDE THE REQUIRED FRICTION CONTACT BETWEEN THE BARRIER SEGMENTS AND THE DECK.

ANCHORS: ONCE ALL BARRIER SECTIONS HAVE BEEN PROPERLY SECURED, REMOVE ALL PORTIONS OF THE ANCHORS THAT PROTRUDE BEYOND THE FACE OF THE BARRIER.

MARKS: CLEARLY MARK ALL BARRIER SEGMENTS ON THE TOP AS SHOWN. XX INDICATES THE YEAR THE BARRIER WAS CAST. THESE MARKINGS SHALL BE PERMANENTLY IMPRESSED IN THE BARRIER USING A MINIMUM OF 2" HIGH LETTERING. EACH SEGMENT SHALL HAVE ON ITS TOP, A UNIQUE IDENTIFICATION AS TO ITS MANUFACTURER; AND, SOMEWHERE ON THE BARRIER, THE DAY AND MONTH THE BARRIER WAS MANUFACTURED.

HANDLING DEVICES MAY BE USED IN LIEU OF THE LIFTING SLOT FOR MOVING THE BARRIER. THE DESIGN OF THE DEVICES SHALL BE SUFFICIENT TO HANDLE THE WEIGHT OF THE SECTION BEING LIFTED. REMOVE ALL PORTIONS OF HANDLING DEVICES THAT PROTRUDE ABOVE THE BARRIER SURFACE.

PROJECT PLANS: THE DESIGNERS SHALL INDICATE THE FOLLOWING INFORMATION ON THE PROJECT PLANS: THE NUMBER OF ANCHORS PER SEGMENT, SPECIAL ANCHORAGE REQUIREMENTS (IF NECESSARY) AND THE LOCATION OF THE BARRIER ON THE BRIDGE DECK.

"J-J HOOKS" END CONNECTIONS MAY BE UTILIZED IN LIEU OF THE END CONNECTIONS DETAILED. NO MODIFICATIONS TO THE REINFORCING STEEL LAYOUT DETAILED HEREIN WILL BE ALLOWED. TRANSITION BARRIER SECTIONS WITH PIN AND LOOP CONNECTIONS ON ONE END AND "J-J HOOKS" ON THE OTHER SHALL BE USED TO CONNECT RUNS OF "J-J HOOKS" BARRIER TO OTHER PERMITTED BARRIER TYPES. THE HEIGHTS OF THE TRANSITION SECTIONS SHALL BE THE SAME AS THE BARRIER RUNS BEING CONNECTED. "J-J HOOKS" IS A TRADEMARK OF: EASI-SET INDUSTRIES, P.O. BOX 300, MIDLAND, VA 22728. (540)439-8911 OR (800)547-4045.

DESIGN AGENCY	OFFICE OF	STRUCTURAL ENGINEERING
STATE OF OHIO DEPARTMENT OF TRANSPORTATION	DATE	4-24-92
ADMINISTRATOR	DATE	4-24-92
REVIEWED	L MW	PCB-91
CHECKED	WTF	PCB-91
DESIGNED	AJM	GFJ
REVISIONS	07-06-99	07-19-02
STANDARD	PORTABLE CONCRETE BARRIER	DETAILS
1	1	