

Plan View  
Flare Rate 7:1

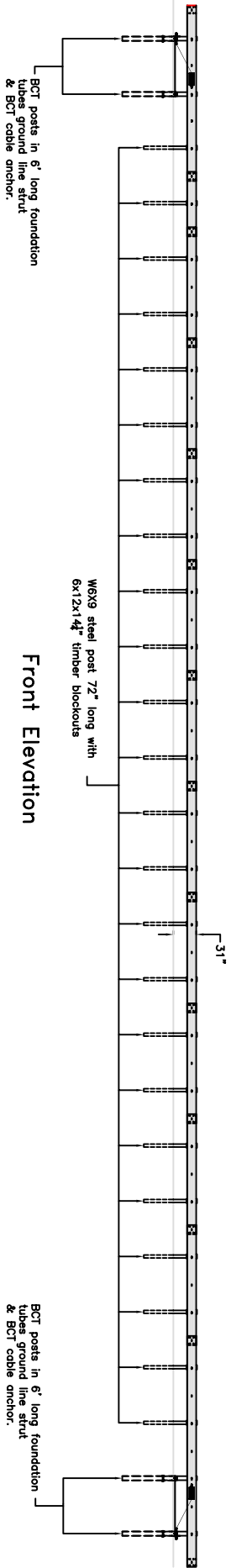

Front Elevation



Midwest Roadside  
Safety Facility

Flare Rate Study (FRS)  
Midwest Guardrail System  
Layout for 7:1 Flare Impact  
with 820C Test Vehicle

Drawing Name:  
FRS-3 R2.dwg

Scale:  
None

Sheet:  
1 of 6

Date:  
08/15/2005

By:  
GEP

Rev:  
KAP

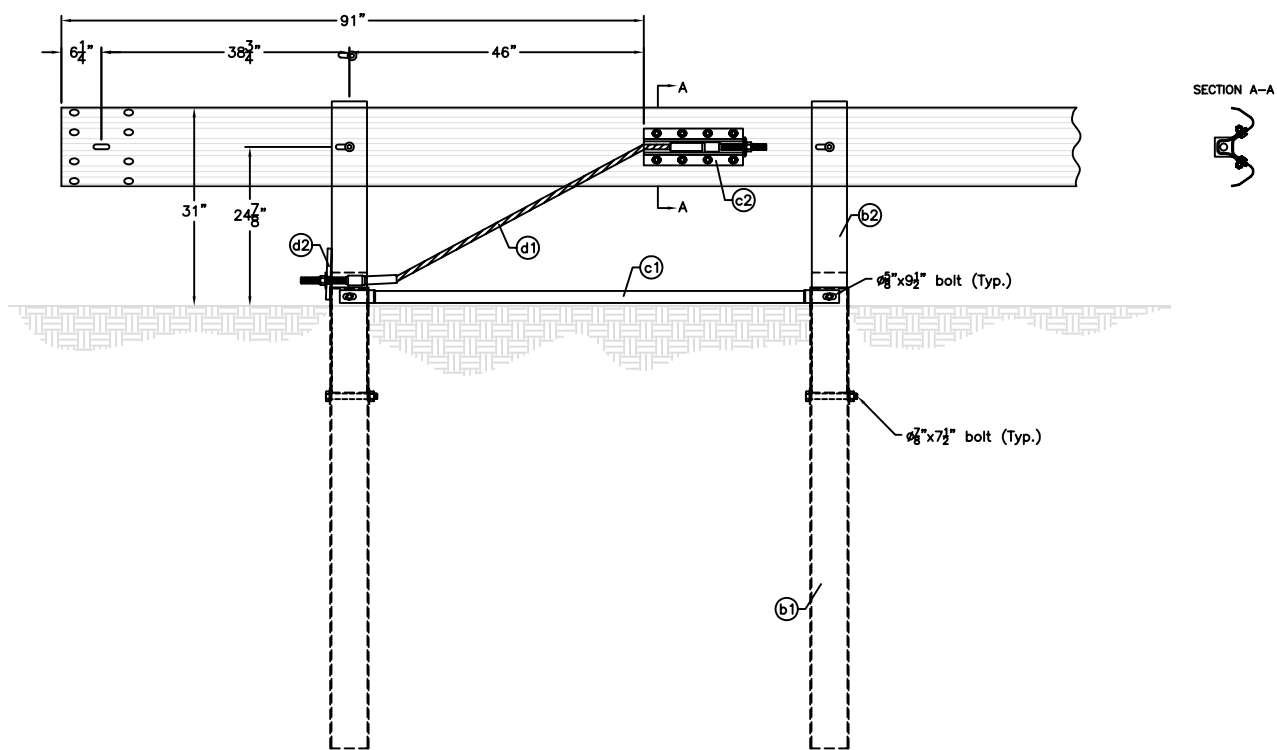
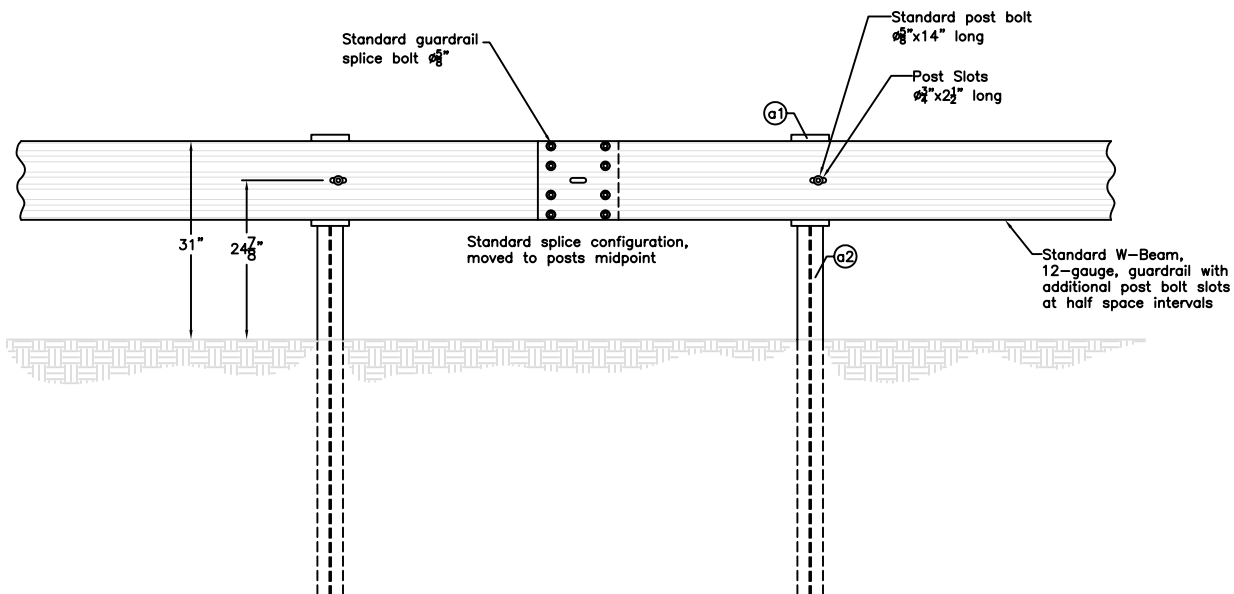

**Midwest Roadside  
Safety Facility**

Flare Rate Study (FRS)  
Midwest Guardrail System

Rail Detail

Sheet:  
2 of 6  
Date:  
08/15/2005  
By:  
GEP  
Rev:  
KAP

Drawing Name:  
FRS-3 R2.dwg

Scale:  
1=30

ITEM	QTY	DESCRIPTION	MATERIAL
a1	25	Steel Posts	W6x9 (W152x13.4)
a2	25	Blockout 6x8x14 $\frac{1}{2}$ "	XXX

**W-BEAM POST  
(Part a1)**

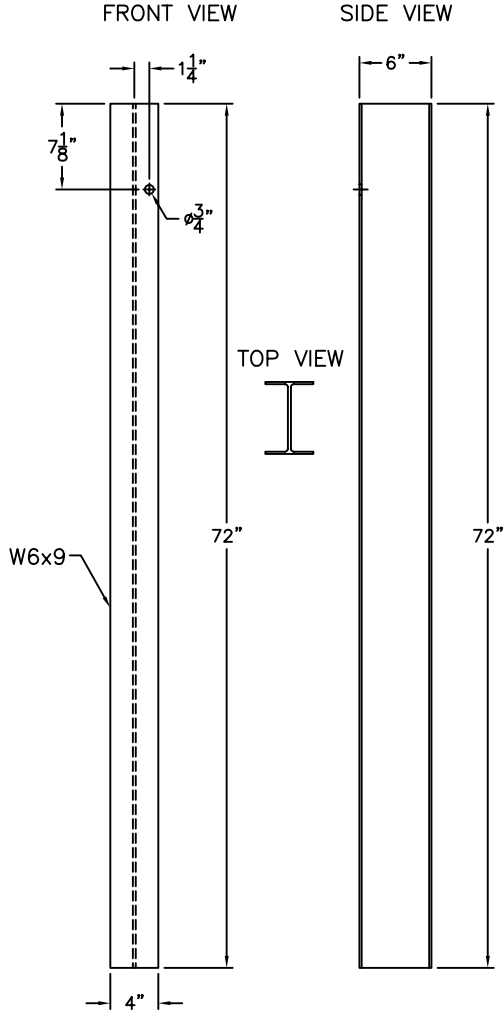

**W-BEAM SPACER  
(Part a2)**

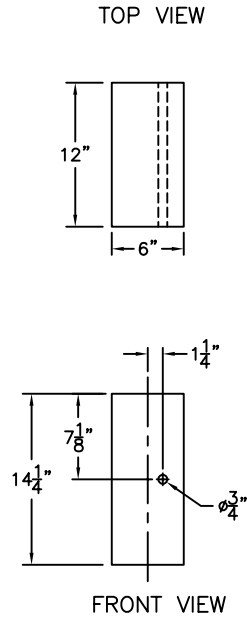

**W-BEAM SUPPORT DETAILS**

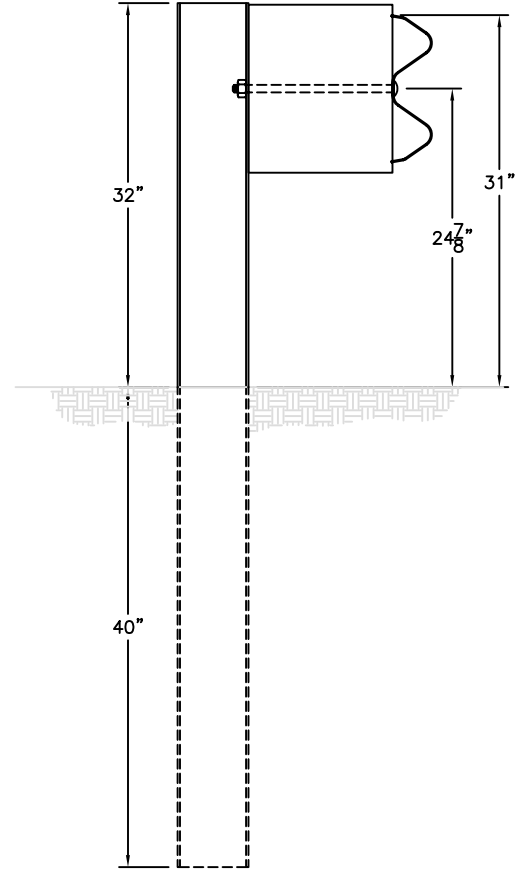

**Midwest Roadside  
Safety Facility**

Flare Rate Study (FRS)  
Midwest Guardrail System

Post Detail

Sheet:  
3 of 6  
Date:  
08/15/2005  
By:  
GEP  
Rev:  
KAP

Drawing Name:  
FRS-3 R2.dwg

Scale:  
1=16

ITEM QTY	DESCRIPTION	MATERIAL
b1 2	Foundation Tubes	PTE05
b2 2	BCT Timber Post	PDF01

**FOUNDATION TUBE  
(Part b1)**

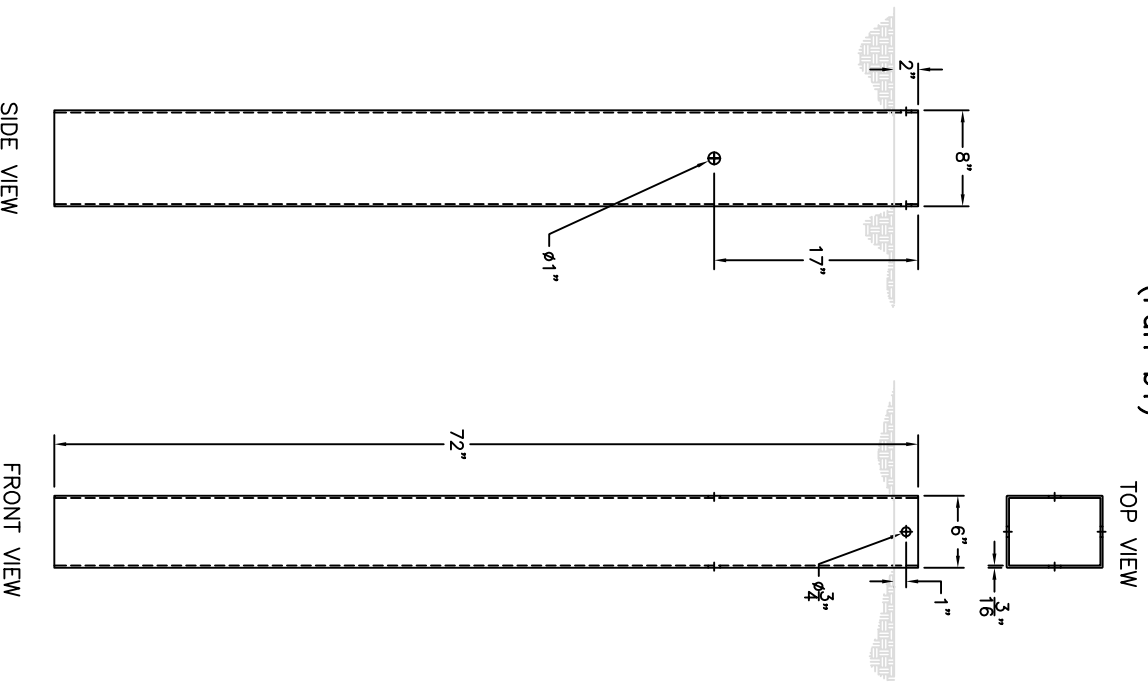

**BCT TIMBER POST  
(Part b2)**

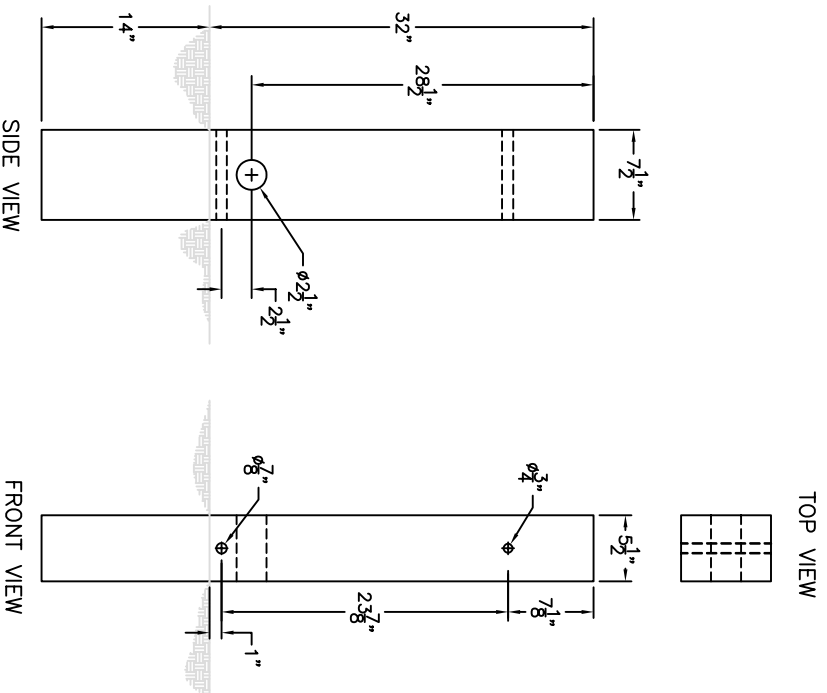

**Midwest Roadside  
Safety Facility**

**Flare Rate Study (FRS)  
Midwest Guardrail System  
BCT Post & Tube Detail**

Drawing Name: FRS-3 R2.dwg	Scale: 1=16	Rev: KAP
Sheet: 4 of 6	By: GEP	Rev: KAP
Date: 08/15/2005	By: GEP	Rev: KAP



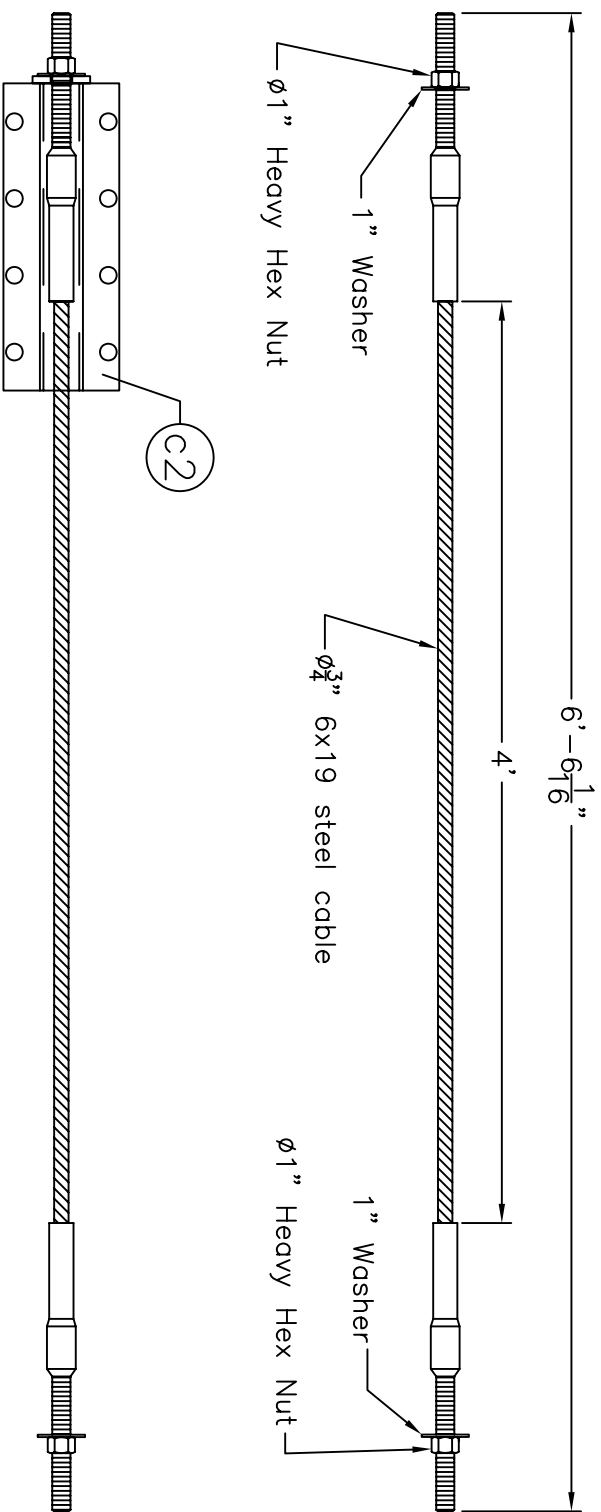

ITEM QTY	DESCRIPTION	MATERIAL
d1 2	Anchor Cable	FCA01
d2 2	Bearing Plate	FPPB01

Anchor Cable  
(Part d1)

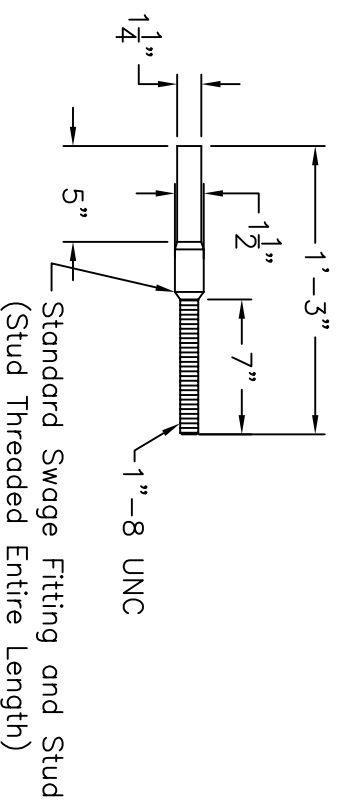
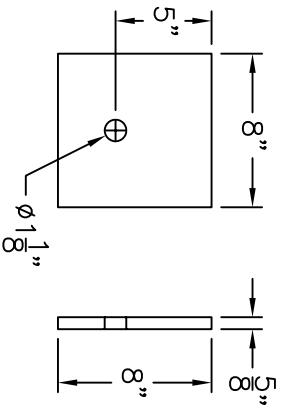

Bearing Plate  
(Part d2)



	<b>Flare Rate Study (FRS) Midwest Guardrail System</b>		Sheet: 6 of 6
	<b>BCT Anchor Cable Detail</b>		Date: 08/15/2005
Drawing Name: FRS-3 R2.dwg	Scale: 1=10	By: GEP	Rev: KAP
Midwest Roadside Safety Facility			